

Authority: Toronto and East York Community Council
Item TE4.13, as adopted by City of Toronto Council on
March 27 and 28, 2019

CITY OF TORONTO

Bill 1501

BY-LAW -2019

To amend City of Toronto By-law 569-2013, as amended, with respect to the lands municipally known in the year 2018 as 545, 555, 561, 565, 583, 589, 591, 595, 599 and 601 Sherbourne Street, 306-334 Bleecker Street, 346-350 Bleecker Street, 354-368 Bleecker Street, 60-68 Earl Street, 280-294 Bleecker Street, 61 Earl Street and 3-7 Howard Street.

Whereas Council of the City of Toronto has the authority pursuant to Section 34 of the Planning Act, R.S.O. 1990, c. P. 13, as amended, to pass this By-law; and

Whereas Council of the City of Toronto has provided adequate information to the public and has held at least one public meeting in accordance with the Planning Act; and

Whereas the Official Plan for the City of Toronto contains provisions relating to the authorization of increases in height and density of development; and

Whereas pursuant to Section 37 of the Planning Act, a by-law under Section 34 of the Planning Act, may authorize increases in the height and density of development beyond those otherwise permitted by the by-law and that will be permitted in return for the provision of such facilities, services or matters as are set out in the by-law; and

Whereas subsection 37(3) of the Planning Act provides that where an owner of land elects to provide facilities, services and matters in return for an increase in the height or density of development, the municipality may require the owner to enter into one or more agreements with the municipality dealing with the facilities, services and matters; and

Whereas the owner of the aforesaid lands has elected to provide the facilities, services and matters hereinafter set out; and

Whereas the increase in height and density permitted beyond that otherwise permitted on the aforesaid lands by By-law 569-2013 as amended, is permitted in return for the provision of the facilities, services and matters set out in this By-law which is secured by one or more agreements between the owner of the land and the City of Toronto;

The Council of the City of Toronto enacts:

1. The lands subject to this By-law are outlined by heavy black lines on Diagram 1 attached to this By-law.
2. The words highlighted in bold type in this By-law have the meaning provided in Zoning By-law 569-2013, Chapter 800 Definitions.

3. Zoning By-law 569-2013, as amended, is further amended by amending the zone label on the Zoning By-law Map in Section 990.10 respecting the lands at 583, 591, 595-597, 599, and 601 Sherbourne Street and 3, 5, and 7 Howard Street, identified as Area A on Diagram 1 of this By-law, and applying the following zone label to these lands: CR 1.5 (c1.0; r1.0) SS2 (x184) as shown on Diagram 2 attached to this Bylaw.
4. Zoning By-law 569-2013, as amended, is further amended by adding **545, 555, 561 and 565 Sherbourne Street, 306-334 Bleecker Street, 346-350 Bleecker Street, 354-368 Bleecker Street, 60-68 Earl Street, 280-294 Bleecker Street and 61 Earl Street**, identified as Area B on Diagram 1 of this By-law, to the Zoning By-law Map in Section 990.10, and applying the following zone labels, CR 1.5 (c1.0; r1.0) SS2 (x184) and OR, to the lands as shown on Diagram 2 attached to this By-law.
5. Zoning By-law 569-2013, as amended, is further amended by adding **545, 555, 561, 565, 583, 589, 591, 595, 599 and 601 Sherbourne Street, 306-334 Bleecker Street, 346-350 Bleecker Street, 354-368 Bleecker Street, 60-68 Earl Street, 280-294 Bleecker Street, 61 Earl Street and 3-7 Howard Street**, to the Policy Areas Overlay Map in Section 995.10.1, and applying the following Policy Area label to these lands: PA 1, as shown on Diagram 3 attached to this By-law.
6. Zoning By-law 569-2013, as amended is further amended by adding **545, 555, 561, 565, 583, 589, 591, 595, 599 and 601 Sherbourne Street, 306-334 Bleecker Street, 346-350 Bleecker Street, 354-368 Bleecker Street, 60-68 Earl Street, 280-294 Bleecker Street, 61 Earl Street and 3-7 Howard Street**, to the Height Overlay Map in Section 995.10.1, and applying the following Policy Area label to these lands: HT 12, as shown on Diagram 4, attached to this By-law.
7. Zoning By-law 569-2013, as amended is further amended by adding **545, 555, 561, 565, 583, 589, 591, 595, 599 and 601 Sherbourne Street, 306-334 Bleecker Street, 346-350 Bleecker Street, 354-368 Bleecker Street, 60-68 Earl Street, 280-294 Bleecker Street, 61 Earl Street and 3-7 Howard Street**, to the Rooming House Overlay Map in Section 995.40.1, and applying the following Rooming House label of B3 to these lands shown on Diagram 5 attached to the By-law.
8. Zoning By-law 569-2013, as amended, is further amended by adding Article 900.11.10 Exception Number 184 so that it reads:

Exception CR 184

The lands, or a portion thereof as noted below, are subject to the following Site Specific Provisions, Prevailing By-laws and Prevailing Sections.

Site Specific Provisions

- (A) On **545, 555, 561, 565, 583, 589, 591, 595, 599 and 601 Sherbourne Street, 306-334 Bleecker Street, 346-350 Bleecker Street, 354-368 Bleecker Street, 60-68 Earl Street, 280-294 Bleecker Street, 61 Earl Street and 3-7 Howard Street**, if the requirements of Section 8 and Schedule A of By-law ____-2019

[Clerks to insert Bylaw #] are complied with, Regulations 40.10.40.10(2) and 40.10.40.40(1) do not apply to prevent the erection of **mixed-use buildings** and **apartment buildings** that comply with (B) to (P) below;

- (B) Despite Regulation 40.10.40.40(1), the maximum gross floor area of Buildings E and F as shown on Diagram 6 of By-law ____-2019, [Clerks to insert Bylaw #] must not exceed 36,000 square metres, of which a maximum of 35,200 square metres may be used for residential uses, and a maximum of 800 square metres may be used for non-residential uses;
- (C) Despite Regulation 800.50(300), in Area B as shown on Diagram 1 of By-law ____-2019, excluding Building E as shown on Diagram 6 of By-law ____ -2019, [Clerks to insert Bylaw #] gross floor area is defined by zoning by-law 438-86 and the maximum gross floor area is 114,950 square metres, of which a maximum of 109,720 square metres may be used for residential uses and a maximum of 5,250 square metres may be used for non-residential uses;
- (D) In Buildings E and F as shown on Diagram 6 of By-law ____-2019, [Clerks to insert Bylaw #] the number of **dwelling units** and types of **dwelling units** must comply with the following:
- i. The maximum total number of **dwelling units** is 545;
 - ii. The minimum number of three-bedroom **dwelling units** is 43; and
 - iii. The minimum number of two-bedroom **dwelling units** is 137;
- (E) Despite Regulations 5.10.40.70(1) and 40.10.40.70(2), the required minimum **building setbacks** are identified on Diagrams 6 and 7 of By-law ____-2019 [Clerks to insert Bylaw #];
- (F) Despite Clause 40.10.40.60 and (E) above, the following are permitted to encroach into the required **building setbacks** shown on Diagram 6 of By-law ____-2019 [Clerks to insert Bylaw #]:
- i. cornices, lighting fixtures, , ornamental elements, eaves, window sills, guardrails, balustrades, railings, wheel chair ramps, thermal insulation and roof ballast, and pipes , to a maximum of 0.3 metres;
 - ii. window washing equipment and vents to a maximum of 3.0 metres;
 - iii. canopies and awnings to a maximum of 3.5 metres; and
 - iv. balconies to a maximum of 2.0 metres, provided they do not project beyond the **lot** line;

- (G) Despite Clause 40.10.40.60 and (E) above, the following are permitted to encroach into the required **building setbacks** shown on Diagram 7 of By-law ____-2019 [Clerks to insert Bylaw #],
- i. awnings, lighting fixtures, ornamental elements, trellises, window sills, balustrades, stairs, stair enclosures, wheelchair ramps, underground garage ramps, landscape and public art features may extend to a maximum of 1.0 metres; and
 - ii. balconies to a maximum of 1.5 metres;
- (H) Despite Regulations 40.5.40.10(1), the height of a **building** or **structure** is measured as follows:
- i. For Buildings E and F as shown on Diagram 6 of By-law ____-2019, as the distance between the Canadian Geodetic Datum elevation of 115.30 metres to the highest point of the **building** or **structure**;
 - ii. in Area B as shown on Diagram 1 of By-law ____-2019, excluding Building E as shown on Diagram 6 of By-law ____-2019, [Clerks to insert Bylaw #] as the distance between the Canadian Geodetic Datum elevation of 114.79 metres to the highest point of the **building** or **structure**;
- (I) Despite Regulation 40.10.40.10(2), the permitted maximum height of any **building** must not exceed the height in metres specified by the numbers following the symbol "HT" on Diagrams 6 and 7 of By-law ____-2019;
- (J) Despite Clause 40.5.40.10 and (I) above, the following **building** elements and **structures** on Buildings E and F as shown on Diagram 6 of By-law ____-2019 may project above the permitted maximum height shown on Diagram 6 of By-law ____-2019 [Clerks to insert Bylaw #],:
- i. stairs and stair enclosures, elevator, heating, cooling or ventilating equipment, mechanical penthouse, wall or structure enclosing such elements to a maximum of 7.5 metres;
 - ii. decks, planters, parapets, railings retaining walls, and roof access hatches to a maximum of 1.5 metres;
 - iii. chimneys, fencing, landscape and public art features, lighting fixtures, ornamental elements, trellises, flues, pipes, stacks, structures located on the roof used for outside or open air recreation, terrace or balcony guard dividers, vents, wind protection and safety features to a maximum of 3.0 metres; and
 - iv. waterproofing materials, pavers and green roof elements to a maximum of 0.4 metres;

- (K) Despite Regulations 40.10.40.10(2), 40.5.40.10, and (I) above, the following **building** elements and **structures** within Area B, as shown on Diagram 1 of By-law ____-2019 [Clerks to insert Bylaw #], excluding Building E as shown on Diagram 6 of By-law __-2019 [Clerks to insert Bylaw #], may project above the permitted maximum height shown on Diagram 7 of By-law ____-2019:
- i. the parapets, terrace guards and dividers, planters, railings, decorative screens, and window washing equipment to a maximum of 1.0 metres;
- (L) A minimum of 3,440 square metres of landscaped open space must be provided on the lands, which may include structures that provide access to an underground parking garage that are both below ground level and above ground level with a maximum height of 3.0 metres and may include structures for venting that are at and/or below ground level provided that the total area of all access structure and venting structures does not exceed 90 square metres.
- (M) Despite Regulation 40.10.40.50(1), **amenity space** must be provided for each building identified on Diagrams 6 and 7 of By-law ____-2019 [Clerks to insert Bylaw #], or on the lands, as follows:
- i. Building A – a minimum of 200 square metres of indoor **amenity space** for the **dwelling units**;
 - ii. Building B – a minimum of 250 square metres of indoor **amenity space** for the **dwelling units**;
 - iii. Building C – a minimum of 223 square metres of indoor **amenity space** for the **dwelling units**;
 - iv. Building D – a minimum of 2.0 square metres of indoor **amenity space** per residential unit within Building D for the **dwelling units**;
 - v. Building E – a minimum of 1,060 square metres of indoor **amenity space** for the **dwelling units**;
 - vi. Building E – a minimum of 630 square metres of outdoor **amenity space** for the **dwelling units**; and
 - vii. A minimum of 3,280 square metres of outdoor **amenity space** must be provided on the lands, excluding the outdoor **amenity space** required for Building E as specified in M.vi. above.
- (N) Despite Regulations 200.5.1.10(2) and 200.5.10.1(1) and Articles 200.15.1 and 200.15.10, **parking spaces** must be provided and maintained on the lands as follows:
- i. a minimum of 597 **parking spaces** must be provided for the residents of the **dwelling units**;

- ii. a minimum of 206 **parking spaces** must be provided on Level P1 for visitors to residents of the **dwelling units** and non-residential uses;
 - iii. a maximum of 93 **parking spaces** may be used as **public parking**;
 - iv. of the total number of **parking spaces** on the lands, a maximum of 243 **parking spaces** may be obstructed on one side; and
 - v. a minimum of 7 accessible **parking spaces**, which must have a minimum width of 3.65 metres and do not require an adjacent barrier-free aisle or path;
- (O) Despite Clause 230.5.10, **bicycle parking spaces** must be provided and maintained for each building identified on Diagrams 6 and 7 of By-law ____ - 2019 [Clerks to insert Bylaw #], or on the lands follows:
- i. Buildings A, B and C – a minimum of 194 long-term **bicycle parking spaces** for the residents of the **dwelling units**;
 - ii. Building D – a minimum of 246 long-term **bicycle parking spaces** for the residents of the **dwelling units**;
 - iii. Building E – a minimum of 475 long-term **bicycle parking spaces** for the residents of the **dwelling units**;
 - iv. a minimum of 150 short-term **bicycle parking spaces** for visitors of the **dwelling units** and non-residential uses for all buildings on the lands, of which a minimum of 40 short-term **bicycle parking spaces** must be provided above ground and the remaining must be located below ground in a secured room on Level P1;
 - v. **bicycle parking spaces** may be **stacked bicycle parking spaces**; and
 - vi. a **stacked bicycle parking space** may overlap an adjacent **stacked bicycle parking space** on one or both sides on the same tier to a maximum of 0.2 metres per side;
- (P) Despite Clause 220.5.10.1(3), **loading spaces** must be provided on the lands in accordance with the following:
- i. a minimum of one **loading space – type "A"**;
 - ii. a minimum of four **loading spaces – type "B"**;
 - iii. a minimum of one **loading space – type "C"** that must be located in Building E as shown on Diagram 6 of By-law ____ -2019 [clerks to insert by-law number]; and

iv. a minimum of two **loading space – type "G"**, one of which will have a minimum vertical clearance of 6.1 metres for 9.5 metres of its length; and

(Q) Despite Regulation 40.10.100.10(1), two **vehicle** accesses are permitted.

Prevailing By-laws and Prevailing Sections: None apply

9. Section 37 Provisions

- (A) Pursuant to Section 37 of the Planning Act, and subject to compliance with this By-law, the increase in height and density of the development is permitted beyond that otherwise permitted on the lands shown on Area A of Diagram 1 in return for the provision by the owner, at the owner's expense of the facilities, services and matters set out in Schedule A hereof and which are secured by one or more agreements pursuant to Section 37(3) of the Planning Act that are in a form and registered on title to the lands, to the satisfaction of the City Solicitor.
- (B) Where Schedule A of this By-law requires the owner to provide certain facilities, services or matters prior to the issuance of a building permit, the issuance of such permit shall be dependent on satisfaction of the same.
- (C) The owner shall not use, or permit the use of, a building or structure erected with an increase in height and density pursuant to this By-law unless all provisions of Schedule A are satisfied.

Enacted and passed on October , 2019.

Frances Nunziata,
Speaker

Ulli S. Watkiss,
City Clerk

(Seal of the City)

SCHEDULE A
Section 37 Provisions

The facilities, services and matters set out below are required to be provided to the City at the owner's expense in return for the increase in height and density of the proposed development on the lands as shown as Area A on Diagram 1 in this By-law and secured in an agreement or agreements under Section 37(3) of the Planning Act whereby the owner agrees as follows:

1. Prior to the issuance of the first above-grade building permit, except for issuance of a building permit solely for the demolition, excavation, shoring or foundation of a building, a building permit for the construction of a temporary sales centre or a building permit for repairs, maintenance and usual and minor works, the owner shall pay to the City the sum of \$2,278,000.00, to be allocated as follows:
 - a. \$1,139,000.00 to be allocated towards local area park or streetscape improvements located in the general vicinity of the land within Ward 13 that comply with the Streetscape Manual and/or are to the satisfaction of the Chief Planner and Executive Director, City Planning, in consultation with the Ward Councillor;
 - b. \$1,139,000.00 to be allocated towards existing and/or new affordable housing that may be owned by Toronto Community Housing, and/or towards existing community facilities, and/or towards recreational space and/or cultural space improvements that may be owned by Toronto Community Housing in the general vicinity of the land within Ward 13, in consultation with the Ward Councillor;
2. The payments required in items 1a and 1b, above, are to be indexed upwardly with the "Non-Residential Construction Price Index for the Toronto Census Metropolitan Area", as reported quarterly by Statistics Canada in Building Construction Price Indexes Publication 327-0058, or its successor, and calculated from the date that the Section 37 Agreement is registered on title to the date of payment of the funds;
3. In the event the cash contributions required in items 1a and 1b above have not been used for the intended purpose within three (3) years of the date of the issuance of the first above-grade building permit, except for issuance of a building permit solely for the demolition, excavation, shoring or foundation of a building, a building permit for the construction of a temporary sales centre or a building permit for repairs, maintenance and usual and minor works, the cash contribution may be directed to another purpose, at the discretion of the Chief Planner and Executive Director, City Planning Division, in consultation with the Ward Councillor, provided that the purpose is identified in the Toronto Official Plan and will benefit the community in the vicinity of the land;
4. Prior to the issuance of the first above-grade building permit for all or any part of the land, except for issuance of a building permit solely for the demolition, excavation, shoring or foundation of a building, a building permit for the construction of a temporary sales centre or a building permit for repairs, maintenance and usual and minor , the *owner* shall convey to the City unencumbered parkland of at least 80.9 square metres that covers a portion of 589 Sherbourne Street and/or adjacent lands, to the satisfaction of the City

Solicitor and the General Manager, Parks, Forestry and Recreation (PFR), in consultation with the Chief Planner and Executive Director, City Planning Division. This conveyance is in addition to the parkland conveyance being secured under Section 42 of the Planning Act, described below in item 6;

5. Prior to the issuance of the first above-grade building permit for all or any part of the land, except for issuance of a building permit solely for the demolition, excavation, shoring or foundation of a building, a building permit for the construction of a temporary sales centre or a building permit for repairs, maintenance and usual and minor works, the owner shall extend the existing park lease to the City on the lands at 583-589 Sherbourne Street, known as St. Jamestown West Park, by an additional 124 years over and above the remaining park lease term. Alternatively, at the City's discretion, the owner shall enter into a new lease with the City that will extend the existing lease by an additional 124 years. Such an extension or new lease, as the case may be, shall be on terms and conditions satisfactory to Deputy City Manager, Corporate Services or his/her designate and the City Solicitor, and shall include any amendments required to give effect to such terms and conditions. Without limitation to the foregoing, the extension or new lease shall provide for the following, unless otherwise agreed to by the Deputy City Manager, Corporate Services, and approved by the City Solicitor, each at her sole discretion, effective as of execution of the lease:
 - a. the land at 583 Sherbourne Street and certain other lands, shall be incorporated into the leased premises, and the lands to be included in the development site and to be conveyed to the City as a parkland conveyance under Section 42 of the Planning Act shall be surrendered from the leased premises;
 - b. as in the existing lease, the rent shall be nominal and the landlord shall be responsible for all taxes and utilities;
 - c. the landlord's termination right currently found in the lease shall be deleted;
 - d. the lease shall have priority over all mortgages, charges or other financial encumbrances against the lands forming the leased premises; and
 - e. the *owner* shall be responsible for, and shall indemnify and save the City harmless from, any land transfer taxes or similar charges payable as a result of the new lease or lease extension.

Parkland Dedication

6. The owner will be required to convey the 607.64 square metre portion of the development site for public parkland purposes, to the satisfaction of the General Manager, PFR and the Chief Planner and Executive Director, City Planning Division. This parkland conveyance includes 526.74 square metres being conveyed under Section 42 of the Planning Act and 80.9 square metres being conveyed under Section 37 of Planning Act (described in item 4 above). The land to be conveyed as parkland shall be free and clear, above and below grade, of all physical obstructions and easements,

- encumbrances and encroachments, including surface and subsurface easements, unless otherwise approved by the General Manager, PFR;
7. The owner is required to convey and lease the parkland to the City prior to the issuance of the first above grade building permit for the all or any part of the land, except for issuance of a building permit solely for the demolition, excavation, shoring or foundation of a building, a building permit for the construction of a temporary sales centre or a building permit for repairs, maintenance and usual and minor works;
 8. The owner is to pay for the costs of the preparation and registration of all relevant documents. The owner shall provide, to the satisfaction of the City Solicitor, all legal descriptions and applicable reference plans of survey for both the conveyed parkland and the leased parkland;
 9. The Parties recognize that there is an existing underground parking structure on the land. Any Base Park Improvements or Above Base Park Improvements noted in the section 37 agreement shall not be construed so as to require the alteration, improvement or removal of the existing underground structure on the Lands except alterations and improvements necessary to support the leased parkland. The lease for the leased parkland shall include, without limitation, the requirements set out in section 5.77 of the section 37 agreement that is entered into pursuant to this Schedule.

Environmental Assessment

10. Prior to conveying the conveyed parkland and/or leasing the leased parkland to the City, the owner must:
 - 10.1 Submit a Qualified Person Preliminary Statement Letter, that is dated and signed by the owner's Qualified Person, as defined in O. Reg. 153/04, as amended, describing the lands to be conveyed and/or leased to the City, and identifying what environmental documentation will be provided to the City's peer reviewer to support this conveyance and/or lease; all environmental documentation consistent with O. Reg. 153/04 requirements shall be submitted with reliance extended to the City and its peer reviewer and any limitation on liability and indemnification is to be consistent with Ontario Regulation 153/04, as amended, insurance requirements or such greater amount specified by the Executive Director of Engineering & Construction Services, and copy to the General Manager, PFR;
 - 10.2 Pay all costs associated with the City retaining a third-party peer reviewer including all administrative costs to the City, and submit an initial deposit of \$ 8,000.00 towards the cost of the peer review in the form of a certified cheque payable to the City Treasurer, to the Executive Director, Engineering & Construction Services. Submit further deposits when requested to cover all costs of retaining a third-party peer reviewer (unused funds will be refunded to the *owner* by the City);

- 10.3 Submit, to the satisfaction of the City's peer reviewer, all Environmental Site Assessment reports prepared in accordance with the Record of Site Condition Regulation (Ontario Regulation 153/04, as amended) describing the current conditions of the parkland to be conveyed and/or leased to the City and the proposed Remedial Action Plan based on the site condition standards approach, to the Executive Director, Engineering and Construction Services;
- 10.4 At the completion of the site assessment/remediation process, submit a Statement from the Qualified Person based on the submitted environmental documents, to the Executive Director, Engineering & Construction Services for peer review and concurrence, which states:
- 10.4.1 In the opinion of the Qualified Person:
- 10.4.1.1 It is either likely or unlikely that there is off-site contamination resulting from past land uses on the parkland that has migrated onto adjacent City lands that would exceed the applicable Site Condition Standards; and
- 10.4.1.2 To the extent that the opinion in 10.4.1.1 is that past migration is likely, it is either possible or unlikely that such off-site contamination on adjacent City lands poses an adverse effect to the environment or human health.
- 10.4.2 Both the conveyed parkland and the leased parkland meet either:
- 10.4.2.1 The applicable Ministry Generic Site Condition Standards (subject to applicable exemptions as stated in O. Reg. 153/04) for the most environmentally sensitive adjacent land use; or
- 10.4.2.2 The Property Specific Standards as approved by the Ministry for a Risk Assessment/Risk Management Plan which was conducted in accordance with the conditions set out herein.
- 10.5 The Qualified Person's statement, referenced in 10.4 above, will include a Reliance Letter that is dated and signed by the owner's Qualified Person, as defined in O. Reg. 153/04, as amended, confirming that both the City and the City's peer reviewer can rely on the environmental documentation submitted, consistent with O. Reg. 153/04 requirements, and the Qualified Person's opinion as to the conditions of the parkland; all environmental documentation consistent with O. Reg. 153/04 requirements and opinions shall be submitted with reliance extended to the City and its peer reviewer and any limitation on liability and indemnification is to be consistent with Ontario Regulation 153/04, as amended, insurance requirements or such greater amount specified by the Executive Director of Engineering & Construction Services.

10.6 For conveyance and/or lease of parkland requiring a Record of Site Condition:

10.6.1 File the Record of Site Condition on the Ontario Environmental Site Registry; and

10.6.2 Submit the Ministry's Letter of Acknowledgement of Filing of the RSC confirming that the RSC has been prepared and filed in accordance with O. Reg. 153/04, as amended, to the Executive Director, Engineering & Construction Services and the General Manager, PFR.

Park Construction: Base Park Improvements

11. The owner, at their expense, will be responsible for base construction and installation of the both the conveyed parkland and the leased parkland. The Base Park Improvements include the following:

11.1 Demolition, removal and disposal of all existing materials, buildings, foundations and associated servicing;

11.2 Grading inclusive of 300 millimetre depth topsoil supply and placement. Where lands have been environmentally risk assessed in accordance with MOECC regulations, the required depth profile of the environmental soil / soft cap will be 1.5 metres of engineered fill compacted to 95 percent SPD and certified by the consulting engineer;

11.2.1 In the case of a risk-assessed site, all materials brought onto the parkland shall comply with the site-specific standards outlined in the Certificate of Property Use. In the case where no risk assessment of the parkland was required, all materials brought on site shall comply with the Ontario Reg. 153/04 Table 3 RPI standards;

11.3 Sod #1 nursery grade or equivalent value of other approved park development;

11.4 Fencing to City standard, where deemed necessary;

11.5 All necessary drainage systems, sanitary and storm service connections, including connections to municipal services and manholes at streetline;

11.6 Water and electrical service connections (minimum water: 50 millimetres to the street line including backflow preventers, shut off valves, water meter and chamber, electrical connection to the street line and electrical panel in a lockable cabinet (100 Amp service));

11.7 Street trees along all public road allowances abutting existing and future City-owned parkland; and;

11.8 Standard park sign (separate certified cheque required).

11. All work described in item 10 above is to be completed to the satisfaction of the General Manager, PFR.
12. The owner shall construct Base Park Improvements for the parkland prior to the conveyance and/or lease of the parkland to the City, to the satisfaction of the General Manager, PFR.
13. Prior to the issuance of the first above grade building permit, except for issuance of a building permit solely for the demolition, excavation, shoring or foundation of a building, a building permit for the construction of a temporary sales centre or a building permit for repairs, maintenance and usual and minor works, the owner shall submit a cost estimate and any necessary plans for the Base Park Improvements, to the satisfaction of the General Manager, PFR.
14. Prior to issuance of the first above grade building permit, except for issuance of a building permit solely for the demolition, excavation, shoring or foundation of a building, a building permit for the construction of a temporary sales centre or a building permit for repairs, maintenance and usual and minor works, the owner shall post an irrevocable Letter of Credit in the amount of 120 percent of the value of the Base Park Improvements for the conveyed parkland and leased parkland to the satisfaction of the General Manager, PFR. No credit shall be given towards the Parks and Recreation component of the Development Charges for costs associated with Base Park Improvements.
15. The construction of the Base Park Improvements to the conveyed parkland and the reinstatement of the leased parkland shall be completed within one year after the issuance of the first above grade building permit, except for issuance of a building permit solely for the demolition, excavation, shoring or foundation of a building, a building permit for the construction of a temporary sales centre or a building permit for repairs, maintenance and usual and minor works, to the satisfaction of the General Manager, PFR. Unforeseen delays (e.g. weather) resulting in the late completion of the construction of the Base Park Improvements to the conveyed parkland and the leased parkland may be taken into consideration and the date for completion may be extended at the discretion of the General Manager, PFR.

Park Occupation Permit

16. Should the owner carry out any of the Base and Above Base Park Improvements on the Parkland following conveyance or lease of the parkland to the City, the owner must obtain, at the owner's expense, a Park Occupation Permit (POP) from PFR's Planning, Design and Development section. The POP will outline in detail the insurance requirements, extent of area permitted, permitted use, tree removal and replacement, and duration to the satisfaction of the General Manager, PFR. The owner will indemnify the City against any claim during any interim use of or work carried out by the applicant on the parkland.

Temporary Fencing

17. Prior to conveyance of the conveyed parkland, the owner shall install temporary fencing around the conveyed parkland and the leased parkland and maintain the fencing until such time as the Park Improvements are completed.

Parkland Grading and Drainage

18. Prior to conveyance and/or lease of the parkland, the owner shall ensure that the grading and drainage for the conveyed parkland and the leased parkland is compatible with the grades of the adjacent lands to the satisfaction of the General Manager, PFR.
19. The owner must provide documentation from a qualified environmental engineer that any fill or topsoil brought onto parkland meets all applicable laws, regulations and guidelines for use in a public park, all to the satisfaction of the General Manager, PFR.

Credit against DC's for Above Base Park Improvements

20. The owner agrees to design and construct the Above Base Park Improvements for a development charge credit against the Parks and Recreation component of the Development Charges, subject to the following condition:
 - 20.1 The owner agrees to design and construct the Above Base Park Improvements to the parkland, to the satisfaction of the General Manager, PFR, for a development charge credit against the Parks and Recreation component of the Development Charges. The development charge credit shall be in an amount that is the lesser of the cost to the owner of installing the Above Base Park Improvements, as approved by the General Manager, PFR, and the Parks and Recreation component of Development Charges payable for the development in accordance with the City's Development Charges By-law, as may be amended from time to time. Prior to the issuance of the first above grade building permit for all or any part of the land, except for issuance of a building permit solely for the demolition, excavation, shoring or foundation of a building, a building permit for the construction of a temporary sales centre or a building permit for repairs, maintenance and usual and minor works, the owner is required to submit a design and cost estimate to be approved by the General Manager, PFR, and a Letter of Credit equal to 120 percent of the Parks and Recreation Development Charges payable for the development, all to the satisfaction of the General Manager, PFR.

Above Base Park Improvements

21. The owner will be responsible to design and construct the Above Base Park Improvements for the conveyed parkland and leased parkland, all to the satisfaction of the General Manager, PFR. Areas to be addressed in the design of the conveyed parkland and the leased parkland are: park programming, sustainable design and plantings, community and public safety, ground surface treatments, seating, and vandalism. Final design and programming of the parkland shall be at the discretion of the General Manager, PFR.

22. Prior to the issuance of the first above grade building permit for the development of all or any part of the land, except for issuance of a building permit solely for the demolition, excavation, shoring or foundation of a building, a building permit for the construction of a temporary sales centre or a building permit for repairs, maintenance and usual and minor works, the owner is required to submit to the satisfaction of the General Manager, PFR:
- 22.1 a schedule for completions of all aspects related to the design of the Above Base Park Improvements;
 - 22.2 working drawings, specification and detailed plans showing the scope and detail of the work for the Above Base Park Improvements for the conveyed parkland and leased parkland;
 - 22.3 a Letter of Credit to the City, to include provision for annual upwards indexing in accordance with the Non-Residential Building Construction Price Index in a form satisfactory to the General Manager, PFR and in an amount equal to the total of 120 percent of the Parks and Recreation Development Charges payable for the development.
23. The construction of the Above Base Park Improvements to the conveyed parkland and the leased parkland shall be completed within one year after the issuance of the first above grade building permit, except for issuance of a building permit solely for the demolition, excavation, shoring or foundation of a building, a building permit for the construction of a temporary sales centre or a building permit for repairs, maintenance and usual and minor works, to the satisfaction of the General Manager, PFR. Unforeseen delays (e.g. weather) resulting in the late delivery of the parkland shall be taken into consideration and the date for completion may be extended at the sole discretion of the General Manager, PFR.
24. As-built drawings in print/hardcopy and electronic format, as well as a georeferenced AutoCAD file, shall be submitted to PFR, upon completion of all the Above Base Park Improvements. A complete set of "as built" plans shall be provided electronically on CD in PDF format, and two (2) sets full size bond hard copy the General Manager, PFR. The plans shall include, but not limited to specifications, locations of all hidden services, and all deviations from the design drawings, shop drawings, inspection reports, minutes of meeting, site instructions, change orders, invoices, certificates, progress images, warranties, close out documentation, compliance letters (for any play structures and safety surfaces), manuals etc. The files are to be organized in folders, including a file index and submitted.
25. Spare or replacement parts, special tools, etc. as provided by manufacturers, if any, are to be provided to PFR, upon completion of all the Above Base Park Improvements.

Wind Mitigation

26. The owner agrees to provide an update of the Pedestrian Level Wind Study by Theakston Environmental dated September 4, 2018, to provide adequate wind mitigation for St. James Town West Park, including both the conveyed parkland and the leased parkland, to the satisfaction of the General Manager, PFR, in consultation with the Chief Planner and Executive Director, City Planning Division. The owner agrees that such updates to the Final Pedestrian Level Wind Study will be done through the City's design process for Above Base Park Improvements for St. James Town West Park. The owner agrees to pay all costs for the updates to the Final Pedestrian Level Wind Study, and, if applicable, all costs for a peer review of the study should a peer review be deemed necessary by the General Manager, PFR or the Chief Planner and Executive Director, City Planning Division.

Warranty

27. The owner, upon completion of the construction and installation of the Base Park Improvements to the satisfaction of the General Manger, PFR, shall provide certification from their landscape architect certifying that all work has been completed. Upon the City's acceptance of the certificate, the Letter of Credit required for the Base Park Improvements will be released less 20 percent which will be retained for the 2 year guarantee known as the Parkland Warranty Period.
28. The owner, upon completion of the construction and installation of the Above Base Park Improvements to the satisfaction of the General Manger, PFR, shall provide certification from their landscape architect certifying that all work has been completed. Upon the City's acceptance of the certificate, the Letter of Credit required for the Above Base Park Improvements will be released less 20 percent which will be retained for a 2 year guarantee period.
29. Upon the expiry of the 2 year guarantee period, the outstanding financial security shall be released to the owner provided that:
- 29.1 there are no outstanding claims against the remaining financial security for the Park Improvements;
 - 29.2 the City has undertaken a lien search at the owner's expense to determine no liens have been registered against the Parkland. The owner will be required to provide a certified cheque in an amount satisfactory to the General Manager, PFR to undertake this search. Any unused funds will be returned to the owner;
 - 29.3 the owner has provided the City with written confirmation that it has not received notice of any claim for lien affecting the parkland;
 - 29.4 all deficiencies have been rectified, and

- 29.5 the owner has provided to the City the certificate of the Park Landscape Architect providing evidence that all lien periods under the Construction Act affecting the parkland have expired.

Heritage Conservation

30. Prior to final Site Plan approval for the subject lands, the owner shall:
- 30.1 Provide final site plan drawings substantially in accordance with the approved Conservation Plan to the satisfaction of the Senior Manager, Heritage Preservation Services;
 - 30.2 Have obtained final approval for the necessary Zoning By-law Amendments required for the subject property, such Amendment to have come into full force and effect;
 - 30.3 Provide a Heritage Lighting Plan that describes how the exterior of the property at 601 Sherbourne Street will be sensitively illuminated to enhance its heritage character to the satisfaction of the Senior Manager, Heritage Preservation Services and thereafter shall implement such Plan to the satisfaction of the Senior Manager Heritage Preservation Services;
 - 30.4 Provide a detailed landscape plan for the property at 601 Sherbourne Street, satisfactory to the Senior Manager, Heritage Preservation Services.
 - 30.5 Provide an Interpretation Plan for the property at 601 Sherbourne Street, to the satisfaction of the Senior Manager, Heritage Preservation Services and thereafter shall implement such Plan to the satisfaction of the Senior Manager, Heritage Preservation Services;
 - 30.6 Submit a Signage Plan for the property at 601 Sherbourne Street to the satisfaction of the Senior Manager, Heritage Preservation Services.
31. Prior to the issuance of any permit for all or any part of the land, including a heritage permit or a building permit, but excluding permits for repairs and maintenance, a temporary sales office, and usual and minor works for the existing heritage building as are acceptable to the Senior Manager, Heritage Preservation Services, the owner shall:
- 31.1 Have obtained final approval for the necessary Zoning By-law Amendments required for the subject property, such Amendments to have come into full force and effect;
 - 31.2 Provide building permit drawings, including notes and specifications for the conservation and protective measures in accordance with to the approved Conservation Plan, including a description of materials and finishes, to be prepared by the project architect and a qualified heritage consultant to the satisfaction of the Senior Manager, Heritage Preservation Services, should a building permit be required for the property at 601 Sherbourne Street;

- 31.3 Provide a Letter of Credit, including provision for upwards indexing, in a form and amount and from a bank satisfactory to the Senior Manager, Heritage Preservation Services to secure all work included in the approved Conservation, Lighting, and Interpretation Plan.
32. Prior to the release of the Letter of Credit required in 35.3 above, the owner shall:
- 32.1 Provide a letter of substantial completion prepared and signed by a qualified heritage consultant confirming that the required conservation work, the required interpretive work, and the required heritage lighting work has been completed in accordance with the Conservation Plan, Interpretation Plan, and Heritage Lighting Plan, and that an appropriate standard of conservation has been maintained, all to the satisfaction of the Senior Manager, Heritage Preservation Services;
- 32.2 Provide replacement Heritage Easement Agreement photographs to the satisfaction of the Senior Manager, Heritage Preservation Services.

Archaeological Assessment

33. The owner agrees to conduct a Stage 2 Archaeological Assessment in accordance with the recommendations provided in the Stage 1 Archaeological Resource Assessment on the lands at 601, 599, 591 and 583 Sherbourne Street, prepared by Archaeological Consultants & Contractors, dated August 9, 2015, to the satisfaction of the Senior Manager, Heritage Preservation Services, City Planning Division.

Rental Housing

34. The owner covenants and agrees to maintain and secure the rental tenure of the one thousand five hundred and twenty-five (1,525) rental dwelling units to be retained in the existing rental apartment buildings municipally known as 545, 555, 561, 565, 601 Sherbourne Street and 3-7 Howard Street, and 280-294 Bleecker Street, 61 Earl Street, 60-68 Earl Street, 306-334 Bleecker Street, 346-350 Bleecker Street, and 354-368 Bleecker Street for a period of at least 20 years commencing from the date that the Zoning By-law Amendments come into full force and effect. None of the rental dwelling units to be retained in the existing rental apartment buildings shall be registered as a condominium, converted to any non-rental housing purpose, or demolished without providing for replacement rental dwelling units during the 20 year period.
35. The owner shall undertake building improvements and renovations to the existing rental building at 601 Sherbourne Street and 3-7 Howard Street at no extra cost to tenants, to the satisfaction of the Chief Planner and Executive Director, City Planning Division, prior to occupancy of the proposed mixed-use building at 591 Sherbourne Street. These building improvements and renovations shall include replacing all flooring and lighting fixtures within the common corridors and entrances and repainting the common corridors and entrances.

36. Prior to the issuance of the shoring and excavation permit for the proposed mixed-use building, the owner shall develop a Tenant Communication Plan and Construction Mitigation Strategy to the satisfaction of the Chief Planner and Executive Director, City Planning Division.
37. The owner shall provide and maintain not less than twenty-four (24) replacement rental dwelling units, comprised of at least ten (10) bachelor, twelve (12) one-bedroom, and two (2) two-bedroom units, within the proposed mixed-use building on the land, for a period of at least 20 years, beginning from the date that each such replacement rental dwelling unit is first occupied, and as generally illustrated in the plans provided to the City Planning Division on December 21, 2018. The minimum unit sizes illustrated in the plans provided to the City Planning Division may vary by a maximum of three percent (3 percent), but only as a result of reasonable adjustments which may be required for the purposes of accommodating final structural or mechanical design. All measurements shall be made in accordance with Tarion Bulletin 22. Any revision to these plans shall be to the satisfaction of the Chief Planner and Executive Director, City Planning Division.
38. The owner shall provide and maintain at least ten (10) bachelor, eight (8) one-bedroom and two (2) two-bedroom replacement rental dwelling units at affordable rents and four (4) one-bedroom replacement rental dwelling units at mid-range rents, for a period of at least 10 years, beginning from the date that each such replacement rental dwelling unit is first occupied.
39. The owner shall provide and maintain at least five (5) one-bedroom market rental dwelling units within the proposed mixed-use building on the site, for a period of at least 20 years, beginning from the date that each such market rental dwelling unit is first occupied, and as generally illustrated in the plans provided to the City Planning Division on December 21, 2018. The five (5) market rental dwelling units shall have unrestricted rents.
40. The owner shall provide and maintain a common laundry room on the second floor of the proposed mixed-use building as illustrated in the architectural floor plans dated December 7, 2018. Any changes to the proposed common laundry room shall be to the satisfaction of the Chief Planner and Executive Director, City Planning Division.
41. The owner shall provide tenants of the replacement rental dwelling units and the market rental dwelling units with access to all indoor and outdoor amenities in the proposed mixed-use building at no extra charge. Access and use of these amenities shall be on the same terms and conditions as any resident of the remainder of the building without the need to pre-book or pay a fee, unless specifically required as customary practices for private bookings.
42. The owner shall provide six (6) vehicle parking spaces to tenants of the replacement rental dwelling units as detailed in the Section 37 Agreement. The terms and conditions for renting one of the designated vehicle parking spaces shall be as set out in the Section 37 Agreement.

43. The owner shall provide bicycle parking spaces in accordance with the zoning by-law amendment, which shall be made available to all residents of the proposed mixed-use building, on a first-come first-serve basis and at no charge;
44. The owner shall provide visitor parking spaces in accordance with the zoning by-law amendment, which shall be made available to all residents of the proposed mixed-use building, on a first-come first-serve basis and at no charge;
45. The owner shall provide central air conditioning in each replacement rental dwelling unit and secured market rental dwelling unit;
46. The owner shall provide tenant relocation and assistance to all eligible tenants of the existing rental dwelling units, including the right to return to a replacement rental dwelling unit, as detailed in the Section 37 Agreement, all to the satisfaction of the Chief Planner and Executive Director, City Planning Division.

Construction Management

47. Prior to the commencement of any excavation and shoring work, the owner will submit a Construction Management and Community Consultation Plan to the satisfaction of the Chief Planner and Executive Director, City Planning Division, the General Manager of Transportation Services, and the Chief Building Official, in consultation with the Ward Councillor, and thereafter shall implement the plan during the course of construction. The Construction Management and Community Consultation Plan will include, but not be limited to, the size and location of construction staging areas, location and function of gates, information on concrete pouring, lighting details, construction vehicle parking and queuing locations, refuse storage, site security, site supervisor contact information, a communication strategy with the surrounding community, and any other matters requested by the Chief Planner and Executive Director, City Planning, or the General Manager of Transportation Services, in consultation with the Ward Councillor.

Municipal Infrastructure

48. The owner agrees to pay for and construct any improvements to the municipal infrastructure in connection with the site servicing report, as accepted by the Executive Director, Engineering & Construction Services, should it be determined that upgrades to such infrastructure are required to support this development.

Toronto Green Standard

49. The owner shall construct and maintain the proposed mixed-use building in accordance with Tier 1 performance measures of the Toronto Green Standard, version 2.

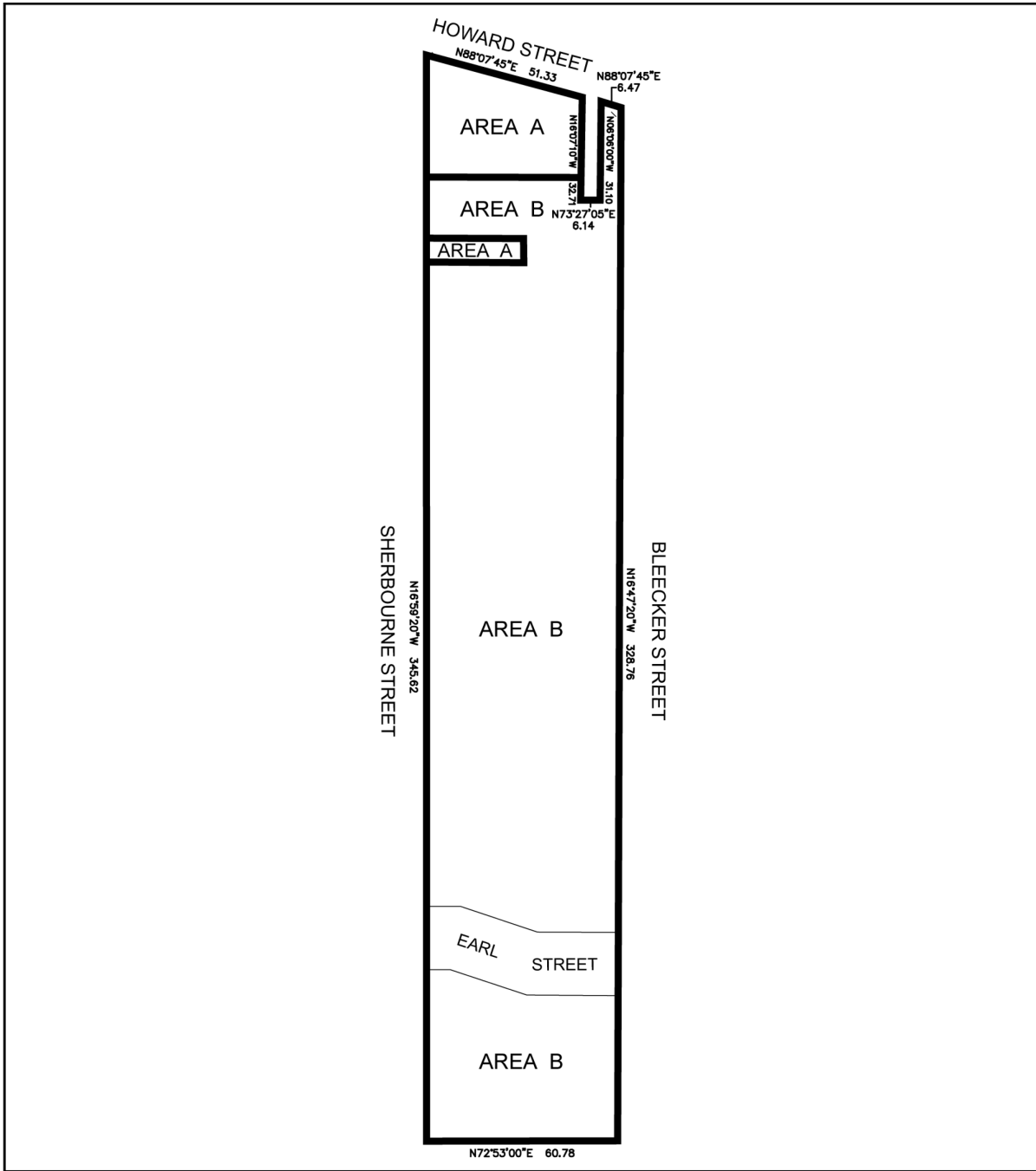

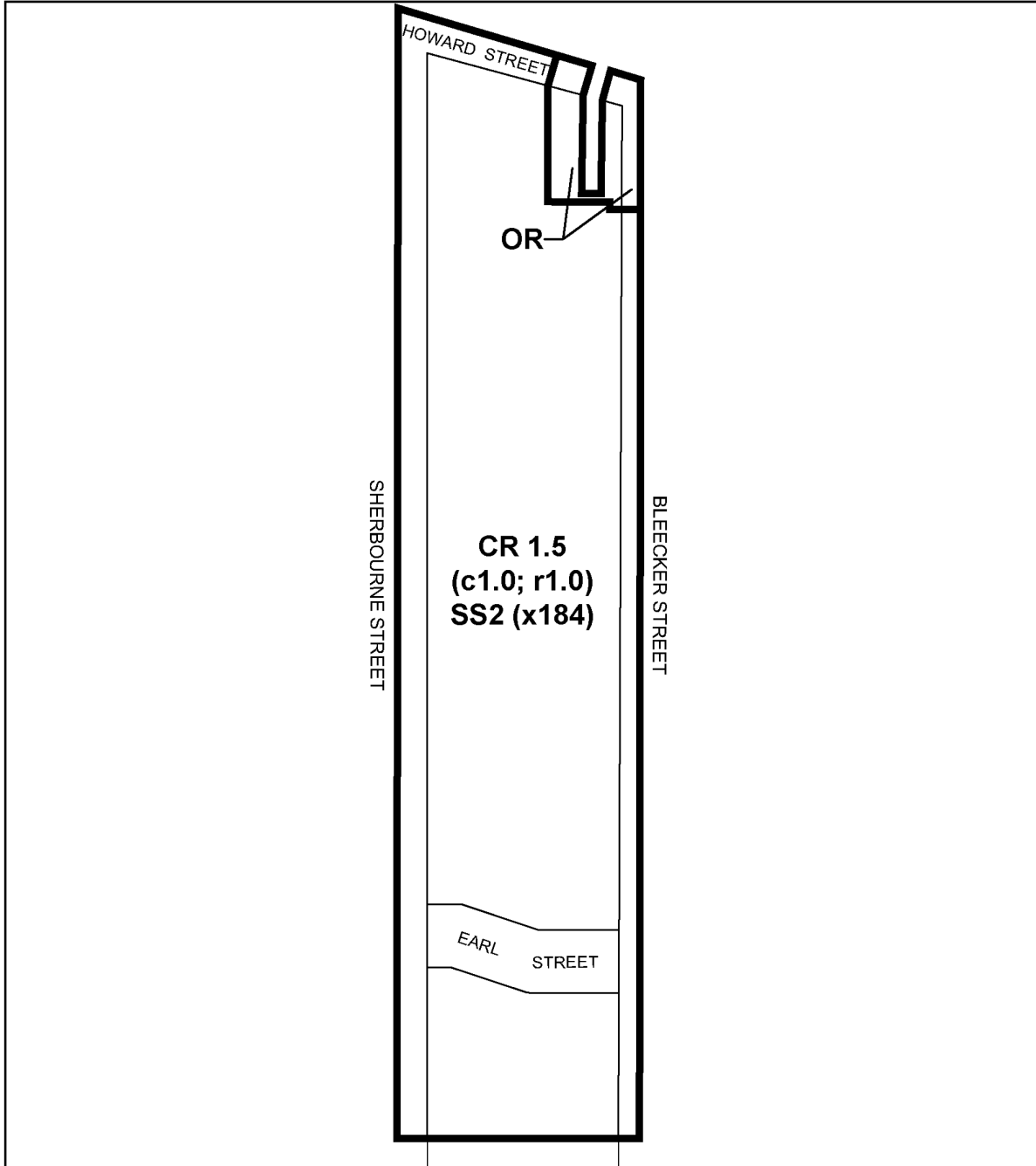

 **TORONTO**
Diagram 2

**545-601 Sherbourne Street
and 3-7 Howard Street**

File # 15 206976 STE 28 OZ

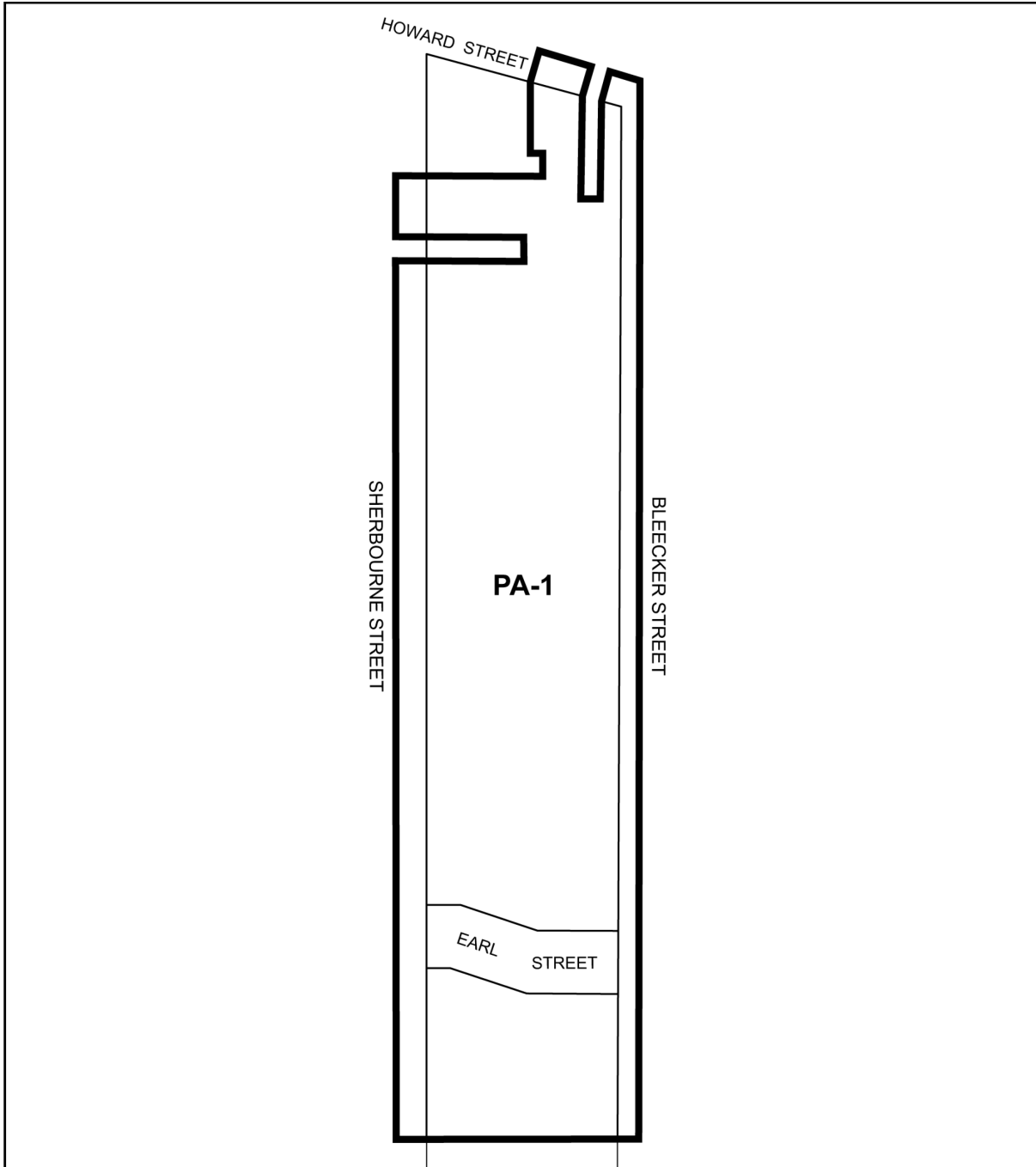

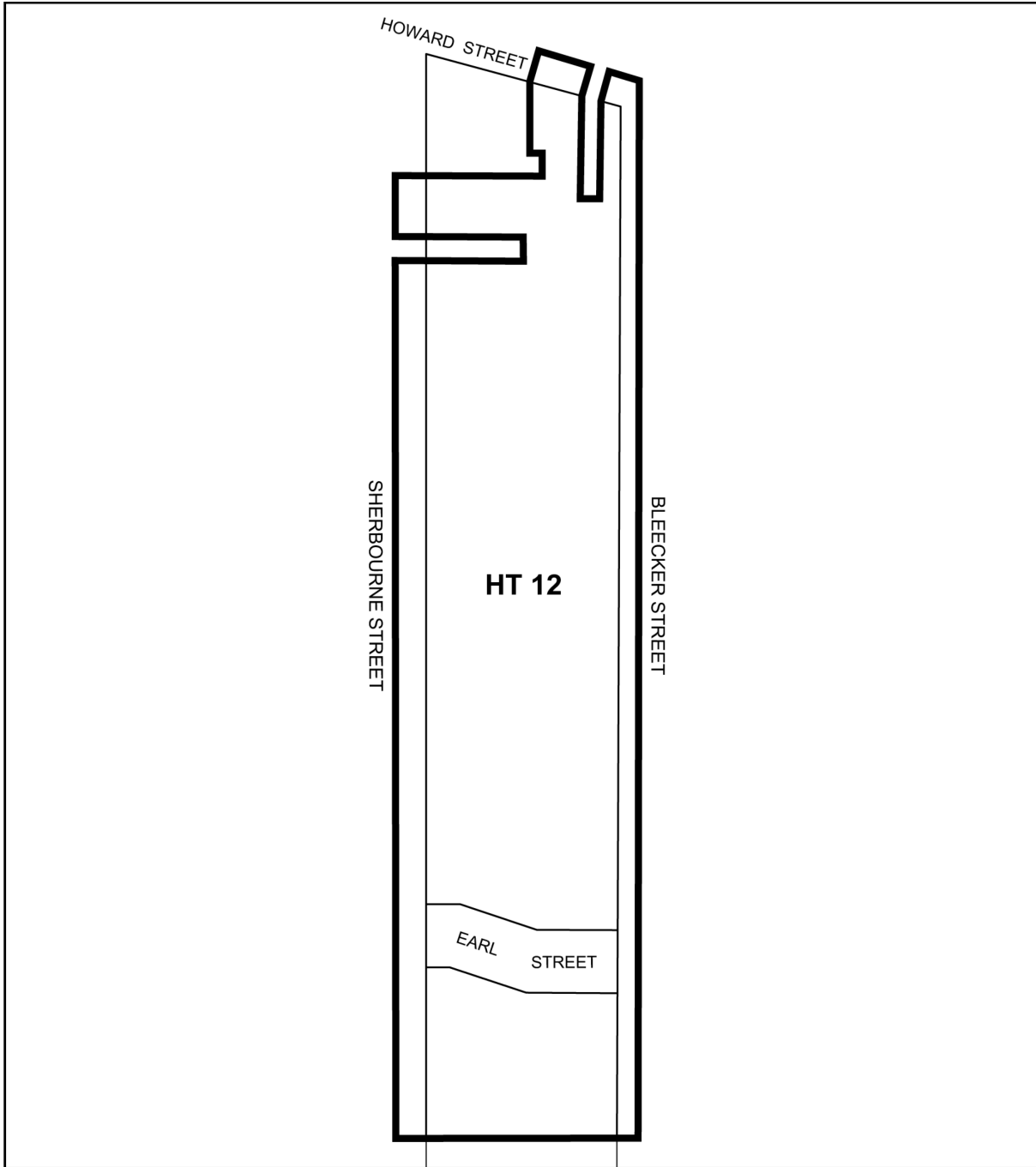

 **TORONTO**
Diagram 4

**545-601 Sherbourne Street
and 3-7 Howard Street**

File # 15 206976 STE 28 OZ

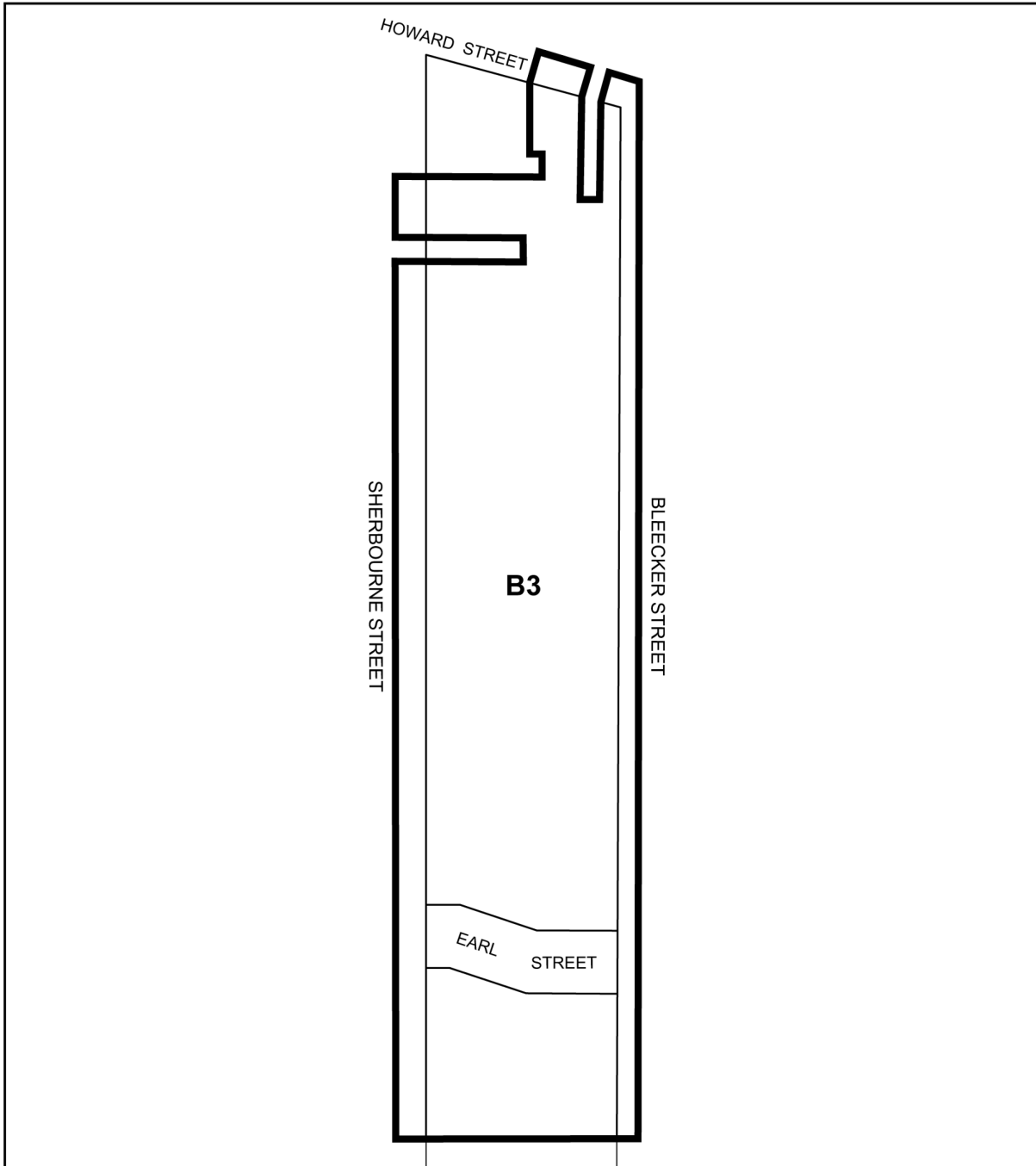

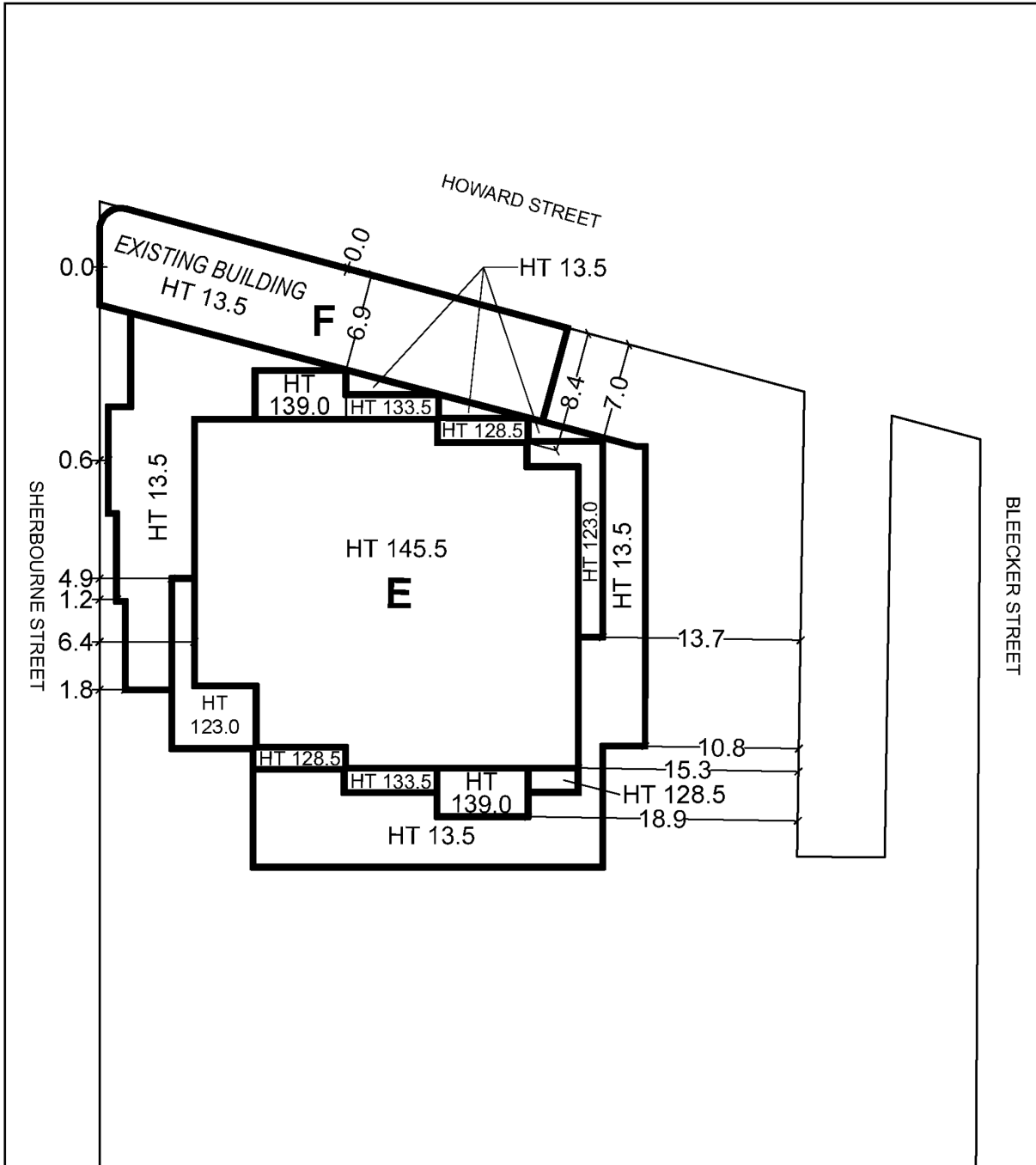

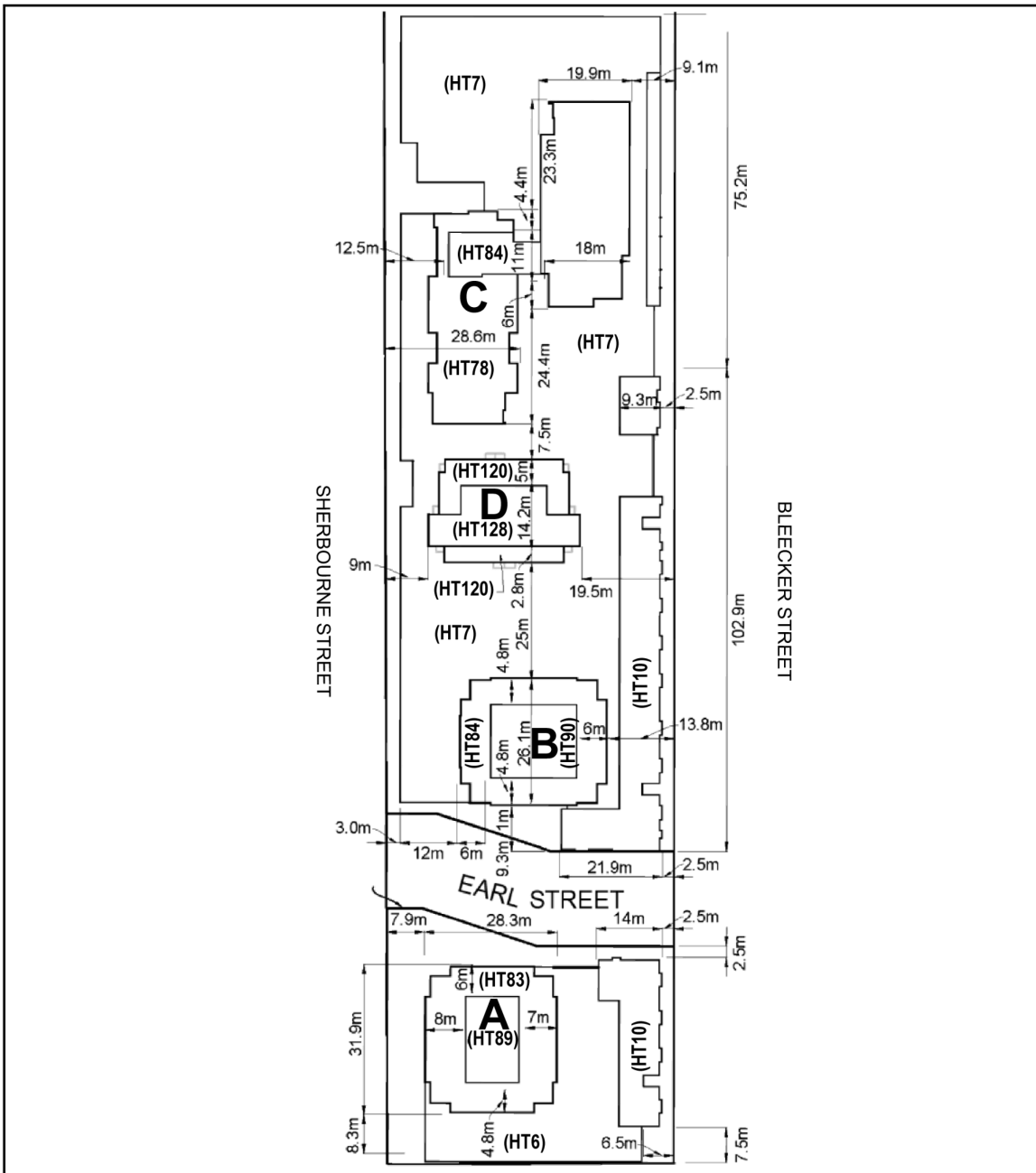

 **TORONTO**
Diagram 7

**545-601 Sherbourne Street
and 3-7 Howard Street**

File # 15 206976 STE 28 OZ