

**Sign Variance Report  
562 Church Street**

<b>Date:</b>	December 3, 2007
<b>To:</b>	Toronto and East York Community Council
<b>From:</b>	Director, Community Planning, Toronto and East York District
<b>Wards:</b>	Ward 27 – Toronto Centre-Rosedale
<b>Reference Number:</b>	07-272072

**SUMMARY**

This staff report is about a matter for which the Community Council has delegated authority from City Council to make a final decision.

This report reviews and makes recommendations on a request by John Feely of D & F Holding Company, for approval of a variance from Chapter 297, Signs, of the former City of Toronto Municipal Code to permit, for third party advertising purposes, replacement of sign structure of an existing illuminated roof sign located on a two storey building at 562 Church Street.

Staff recommends refusal of this application. The variance is major and not within the general intent and purpose of the Municipal Code.

**RECOMMENDATIONS**

**The City Planning Division recommends that:**

1. Toronto and East York Community Council refuse the request for a variance to permit, for third party advertising purposes, replacement of sign structure of an existing illuminated roof sign located on a

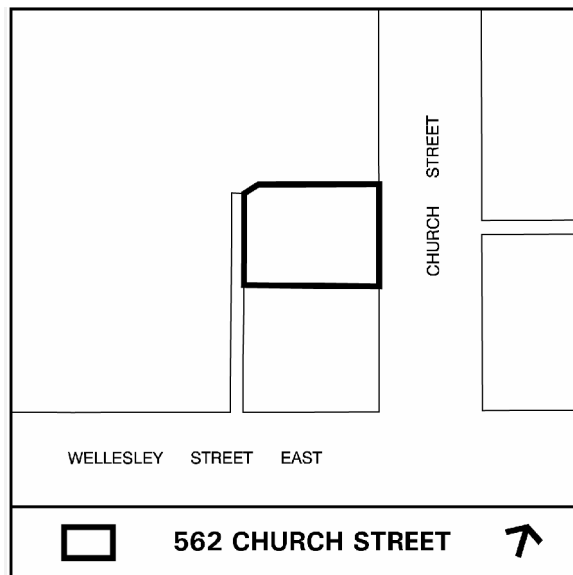

two storey building at 562 Church Street.

### **Financial Impact**

The recommendations in this report have no financial impact.

### **ISSUE BACKGROUND**

The property is located north of Carlton Street, on the west side of Church Street in a CR zone. The property contains a two-storey building. The applicant is requesting permission to replace, for third party advertising purposes, the sign structure of an existing non-conforming illuminated roof sign located on the building. The sign is 12.19m wide and 3.05m high with an area of 37.18m<sup>2</sup>. The sign height from roofline to the top of the sign is 7.62m

The sign does not comply with Chapter 297, Signs, of the former City of Toronto Municipal Code in the following ways:

<b>Sign By-law Section and Requirements</b>	<b>Applicant's Proposal</b>	<b>Required Variance</b>
1. Chapter 297-10D (16)	To replace the sign structure of an existing illuminated non-conforming roof sign, for third party advertising purposes, located on top of a two-storey building located in a CR zone.	A third party roof sign on a building located in a CR or MCR zone is not permitted.

### **COMMENTS**

This proposal seeks an exception to the limited permissions for changing the characteristics or attributes of legal non-conforming roof signs located on the lands in the areas referred to in section 297-11(B) and an additional 10 site specific locations listed under section 297-13(B).

At its meeting of April 24, 1995, City Council passed By-law 1995-0229 to amend Chapter 297 of the Municipal Code to prohibit roof signs in all CR and MCR zone districts in the former City of Toronto. The prohibition resulted from a study of signage along the City's "Main Streets" which detailed the unattractive appearance of roof signs within the mixed-use zone districts and from adjacent residential districts as well as the negative effect on skyline views.

The proposed replacement of the existing roof sign structure would extend its physical life-span and improve its marketability. This would contravene the intent of the existing policy to not extend the life-span of non-conforming roof signs and to encourage their removal.

Staff recommends refusal of this application. The variance is major and not within the general intent and purpose of the Municipal Code.

## **CONTACT**

Norm Girdhar, Assistant Planner  
Telephone: 416-392-7209  
Fax No. 416-392-1330  
E-mail: ngirdhar@toronto.ca

## **SIGNATURE**

---

Gary Wright, Director  
Community Planning, Toronto and East York District

(P:\2007\Cluster B\pln\teycc30015490042.doc) - smc

## **ATTACHMENTS**

Attachment 1: Elevations & Details

Attachment 1: Elevations & Details

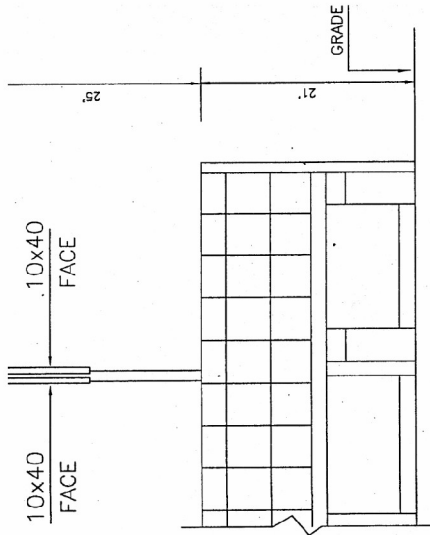

EAST ELEVATION

CHURCH ST.

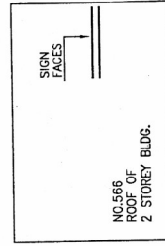

PLAN OF BUILDING

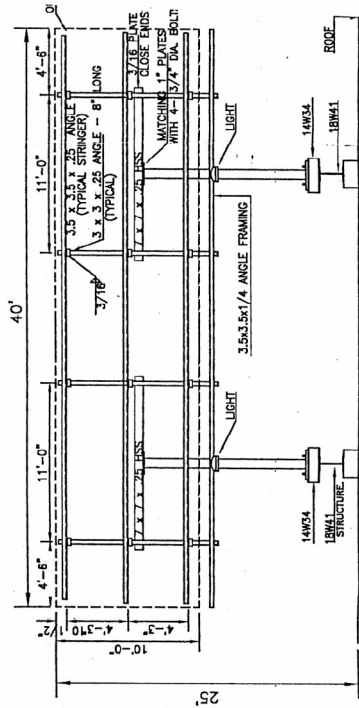

FRONT ELEVATION

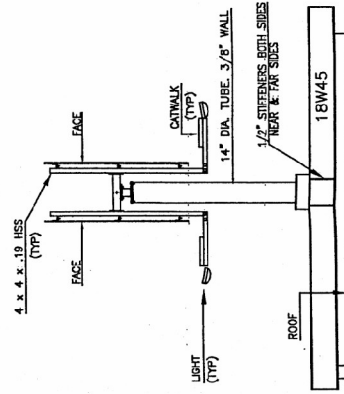

562 Church Street

Elevations & Details

Applicant's Submitted Drawing

Not to Scale  
11/26/07

File # 07\_272072