

Avenue Road Avenue Study Lawrence Avenue to Wilson Avenue

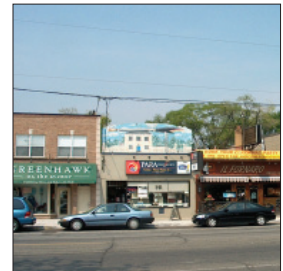

Brook McIlroy Planning + Urban Design/Pace Architects

in association with

Poulos + Chung Limited

April 2008

Brook McIlroy Planning + Urban Design | Pace Architects

51 Camden Street, Suite 300

Toronto, ON, M5V 1V2

tel: (416) 504-5997

fax: (416) 504-7712

www.brookmcilroy.com

Poulos and Chung Limited

535 Bur Oak Avenue

Markham, ON, L6C 2S5

tel: (905) 479-7942



avenue road

TABLE OF CONTENTS

EXECUTIVE SUMMARY	iv
1 INTRODUCTION & CONTEXT	01
1.1 Study Context	01
1.2 Avenue Studies	01
1.3 Study Process	02
1.3.1 Consultant Team	03
1.3.2 Document Structure	03
1.3.3 The Local Advisory Committee (LAC) Participation & Acknowledgements	04
1.4 Study Components	05
2 EXISTING CONDITIONS	06
2.1 Study Framework	06
2.1.1 Previous Official Plan	06
2.1.2 New Official Plan	06
2.1.3 Existing Zoning	07
2.2 Area Conditions	08
2.2.1 Predominant Building Uses & Characteristics	09
2.2.2 Parks & Open Spaces	12
2.2.3 Community Services & Facilities	12
2.2.4 Vehicular Circulation	14
2.2.5 Transit	15
2.2.6 Parking	15
2.2.7 Larger Sites - Opportunity Sites	16
2.2.8 Retail Study	18
3 RECOMMENDATIONS	22
3.1 Study Vision	22
3.2 Guiding Principles	22
3.3 Greening the Avenue	24
3.3.1 New Parks & Open Spaces	25
3.3.2 Green Fingers	26
3.3.3 Green Street Medians	27
3.3.4 Green Public Lanes	27
3.3.5 Douglas Greenbelt	28
3.3.6 Green Space in New Developments	30
3.3.7 Green Building Standards	30
3.4 Identity of the “Upper Avenue”	31
3.5 Public Realm Amenities	32
3.5.1 Gateways & Public Art	32
3.5.2 Coordinated Street Furniture	33
3.5.3 Rooftop Billboards	35

3.6	Built Form Recommendations	36
3.6.1	Height & Massing Principles for Base Condition	36
3.6.2	Height & Massing Principles for Larger Opportunity Sites	40
3.6.3	FSI & Density	51
3.6.4	Front Property Building Setbacks	52
3.6.5	Impacts From Developments	53
3.7	Other Recommendations	55
3.7.1	Ground-Floor Retail & Mix of Uses	55
3.7.2	Home Occupations	56
3.7.3	Side Street Commercial	57
3.7.4	Traffic & Vehicular Access	58
3.7.5	Parking	58
3.8	Community Association	59
3.9	Section 37	59
4	DESIGN GUIDELINES	60
4.1	Built Form	60
4.1.1	Building Orientation and Layout	60
4.1.2	Built Form & Massing	61
4.1.3	Building Façade Articulation	62
4.1.4	Building Materials & Details	64
4.1.5	Sustainable Building Design	65
4.2	Vehicular Movement: Parking & Access	66
4.2.1	Vehicular Access	66
4.2.2	Structured Parking	66
4.2.3	Surface Parking	67
4.2.4	Servicing & Loading	68
4.3	Streetscaping & Landscaping	69
4.3.1	Sidewalks & Streetscaping	69
4.3.2	Landscaping	69
4.3.3	Parks & Open Spaces	70
4.3.4	Public Art	71
5	IMPLEMENTATION	72
5.1	Implementation Recommendations	72
5.1.1	Zoning By-law and Official Plan Policies	72
5.1.2	Other Recommendations	72
5.2	Community-City Partnerships	73
5.2.1	Community Association	73
5.2.2	Design Review	73
5.3	Ongoing Monitoring & Evaluation	73
APPENDICES		
A - Summary of Public Consultation		
B - Community Services and Facilities Assessment		



executive summary

The following document was prepared by Brook McIlroy Planning and Urban Design (BMI/Pace) in association with Poulos + Chung Limited, for the City of Toronto as part of the Avenue Studies policy identified in the City's Official Plan.

The City of Toronto Official Plan calls for a significant proportion of future growth along the Avenues. Among the hundreds of kilometers of eligible streets, Avenue Road between Lawrence Avenue West and Wilson Avenue was selected as an one of three Avenue Studies to be undertaken in 2007.

The Avenue Road Avenue Study addresses the two-kilometre length of Avenue Road between Lawrence Avenue West and Wilson Avenue. This study will provide a long-term plan for the area that combines a community vision and the City's intention to update and implement zoning that is defensible and clear for both the local community and respected by the development community.

The community consultation process included three public meetings, seven Local Advisory Committee (LAC) meetings, a working charrette and walking tour with the LAC, as well as consultation with area stakeholders and representatives. Many of the recommendations contained in this study were developed and refined through ongoing discussions with the LAC. Not all of the resulting recommendations garnered consensus from the LAC group.

The following provides a summary of the key study findings, recommendations and associated implementation strategies. Additional analysis and background information is provided in subsequent chapters.

Study Findings

There has been limited redevelopment in this section of Avenue Road over the last few decades. The Bedford Glen condominium constructed at the south end of the study area in the 1970's, was the last major residential development in the area. Over the last year a mid-rise condominium was approved by the City, along with several other small-scale retail redevelopments. The pace of growth in this area is likely to be incremental given the fragmented nature of property ownership.

The growing popularity of the surrounding residential areas, increased demand for city living, the need for residential housing choices and proximity to retail

and public transportation makes this area a potential candidate for redevelopment and intensification.

Recommendations

This study recommends a series of amendments to the existing policy framework and zoning bylaws that will encourage redevelopment at an appropriate scale. The study also outlines key public open space improvements and urban design/built form guidelines to encourage high quality development. These recommendations have been developed and shared with the public through a series of public workshops, open houses and Local Advisory Committee meetings. The key recommendations of this study focus on creating conditions for smaller-scale, mid-rise developments of five-storeys with limited opportunities for larger-scale developments up to seven-storeys. The function of Avenue Road as a primarily retail-oriented street should be retained and new development or redevelopment will be required to maintain an active retail frontage.

Many of the recommendations developed through the course of this study focus on creating more open and green spaces and enhancing the existing open spaces within the community.

Implementation Strategies

The City should consider the following implementation strategies to move forward with the recommendations of this Study:

Amend the zoning by-law, sign by-law and the Official Plan, including:

- Increase allowable height to five-storeys along the length of Avenue Road (Section 3.6.1);
- Increase allowable height to seven-storeys on the nine identified larger sites (Section 3.6.2);
- Increase permitted density to 3x for the entire Avenue Road study area;
- Amend the Official Plan to designate all of the Douglas Greenbelt lands as Public Open Space (Section 3.3.5);
- Create an Official Plan Amendment to allow for side street commercial to remain, but only in house form and/or scale (Section 3.7.3);
- Amend the By-law 1-83 to allow home occupation in the broader study area (Section 3.7.2);
- Amend the Sign By-law (Section 3.5.3) to prohibit the erection of additional roof signs on this section of Avenue Road.

Other recommendations, include:

- Adopt the urban design guidelines (Section 4);
- Include paid public parking (i.e. Green P) in new developments in the south half of the study area (Section 3.7.5);
- Purchase land to provide an access from the Douglas Greenbelt to Glengarry Street to create a southerly access (Section 3.3.5);
- Acquire the Roe TTC Loop when declared surplus for the creation of a public park (Section 3.3.1);
- Investigate closure of the Dunblaine Avenue right-of-way at Avenue Road to create a park. Some residents on Dunblaine Avenue were informally surveyed about closing-off the street and indicated support for this proposal (Section 3.3.1);
- Consult City divisions regarding opportunities to improve, landscape and maintain leftover areas of open space within the public right-of-way to develop and construct the “green fingers” (Section 3.3.2);
- Prepare a Public Realm Study for Avenue Road to consider all of the improvements recommended to the Public Realm (the City would prepare this document);
- Conduct an area traffic study to identify problems and measures to discourage cut-through traffic and improve pedestrian safety on local streets east and west of Avenue Road (Section 3.7.4);
- Preserve the front setbacks on Avenue Road north of Melrose Avenue (Section 3.6.3); and
- Include sites on Avenue Road in the City of Toronto’s Public Art Master Plan (Section 3.5.1).

Build on Community-City Partnerships, including the development of:

- A Community Association (Section 3.8); and
- Review of projects in the study area by a local Design Review Panel. Significant projects should be reviewed for compliance with this Study.

Ongoing Monitoring and Evaluation

Over time the City of Toronto will need to amend policies in response to experience, trends and feedback from stakeholders. There should be a monitoring process to review the success of each new development project upon its completion. This review should inform the implementation of the next project to ensure that new buildings respond to the changing conditions of the area.

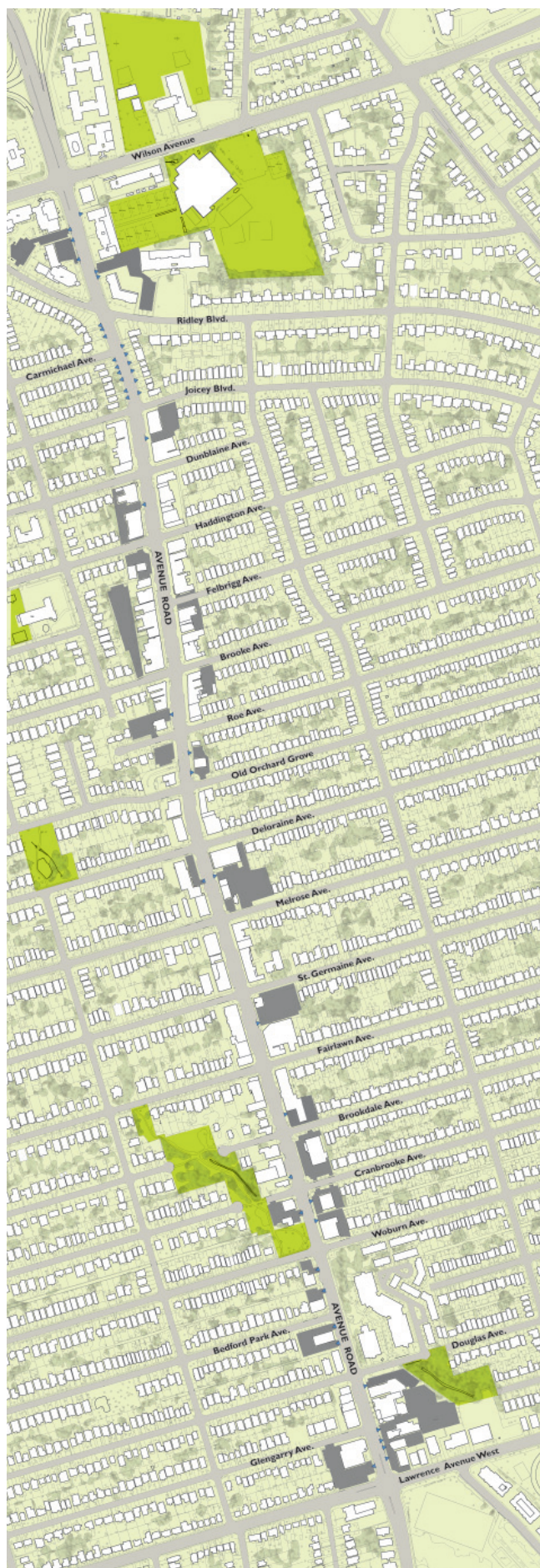

1 introduction & context

1.1 Study Context

As part of an ongoing series of Avenue Studies being prepared for the City of Toronto, Brook McIlroy Planning + Urban Design and Pace Architects (BMI/Pace) was retained in early 2007 to prepare a Planning and Urban Design Study of Avenue Road between Lawrence Avenue West and Wilson Avenue.

This section of Avenue Road is unlike most other Avenue Studies undertaken by the City. Avenue Studies have typically been targeted at streets that are in need of revitalization or major streetscape improvements. Avenue Road is different because it does not suffer from lack of development interest. It is a vibrant retail shopping street that has recently undergone major streetscape upgrades and is surrounded by upscale and healthy residential neighbourhoods. Major streetscape improvements were not deemed to be appropriate in this context due to the significant road reconstruction undertaken in 2006 and 2007. Smaller scale open space and streetscape design recommendations were made as part of the study.

The purpose of this Avenue Study is to anticipate the future growth of the Avenue and to create an updated and defensible policy and urban design framework for making decisions on future development applications.

1.2 Avenue Studies

Avenue Studies had their genesis in the new Official Plan. The Plan recognized that Toronto will continue to grow modestly in both population and employment. Council clearly stated that the character of established low rise neighbourhoods was to be protected, and the majority of the population growth was to be directed to the Downtown, the four Centres and along mixed-use arterial 'Avenues'. Since Council adopted the Plan in 2002, seventy percent of new residential development in Toronto has gone into these 'growth' areas.

There are one-hundred and eighty kilometres of Avenues identified in the Official Plan in Toronto (see map below). Each Avenue is very different in terms of lot sizes and configuration, economic health, uses and the quality of the streetscape. There is no 'one size fits all' program for the Avenues. Instead, over time, each Avenue will be studied together by staff, local residents and the business community to come up with a framework for change.

This portion of Avenue Road is the twelfth Avenue Study the City has embarked on. Council has adopted criteria for selecting the Avenues to be studied. The criteria include: the presence of vacant and underutilized land with redevelopment potential including large vacant areas or areas of surface parking, existing zoning that is an impediment to improvement, and need for streetscape improvements.



Map of Avenues as areas of intensification identified in the Official Plan. (Map source: City of Toronto Official Plan)

1 introduction & context

1.3 Study Process

This Avenue Study is the result of collaboration between the consultant team and City staff, with significant input from the Local Advisory Committee (LAC). The process was initiated in April 2007 and incorporated three distinct stages of work:



Phase One – Research & Consultation

City staff and the consultant team held a kick-off meeting and site tour at the outset of the project. The first public Open House was held on May 1, 2007 to introduce the project to the community and the first two LAC meetings were held during this phase. The LAC included approximately twenty-eight volunteer members comprised of residents and business owners. The team prepared a detailed inventory of existing planning policies, review of on-going and planned development activity, and an analysis of existing urban form. A number of site visits were conducted, and a photographic inventory and historical research were prepared.



Phase Two – Principles, Ideas & Consultation

The Phase 1 analysis informed the Phase II guiding principles and guidelines for the Avenue. 3-D models, diagrams and precedent images were developed to demonstrate urban design options for public and stakeholder input. During this phase a charrette was facilitated by BMI with the assistance of Michael Spaziani (Michael Spaziani Architects) and City staff. The charrette summarized the research and analysis, including existing conditions, precedents study, preliminary design principles and preliminary design concepts. The presentation was followed by break-out groups that developed their own vision for the Avenue. Throughout this Phase, the Team continued to meet with the LAC and other stakeholders and refine the principles and recommendations. A second open house was conducted in September, 2007.



Phase Three – Synthesis & Final Report

The final open house was held on November 6, 2007 and final LAC meetings were held in this phase. This report is based on the outcomes and feedback and general consensus gathered throughout Phases 1 and 2. Avenue Road has recently been reconstructed to improve the boulevard, sidewalk and other amenities within the public right-of-way. This report therefore primarily focuses on urban design recommendations for building heights and massing, building façade articulation and improvements to parks and open space.

1.3.1 Consultant Team

The Avenue Road Avenue Study is a joint effort by the City's Planning staff (including Community Planning, Urban Design, Transportation and Policy & Research staff), and the consultant team. Upon completion of this study, and in consultation with the local community, City Planning staff will prepare area-specific zoning to guide development. The new zoning by-law will establish an appropriate and defensible mix of uses, heights, densities, setbacks and other zoning standards. These standards will be supplemented with urban design guidelines.

The Consultant Team includes:

Brook McIlroy Planning + Urban Design Pace Architects
(Project Leaders, Planning and Urban Design)

Poulos + Chung Limited
(Traffic and Transportation)

1.3.2 Document Structure

This study is divided into the following five sections including appendices:

- **Chapter 1** introduces the project team and study process.
- **Chapter 2** provides an overview of the Avenue Road corridor and the communities surrounding the Avenue. This includes a discussion of the policy context.
- **Chapter 3** summarizes the consultant team's recommendations. Many recommendations were developed in consultation with the LAC.
- **Chapter 4** outlines the design guidelines that are specific to the area.
- **Chapter 5** includes implementation recommendations.



Avenue Road has a diversity of building types, built form and uses.

1 introduction & context

1.3.3 The Local Advisory Committee (LAC) Participation & Acknowledgements

The Local Advisory Committee (LAC) is comprised of local area residents, business owners and property owners. At the first public meeting on May 1, 2007, where approximately twenty-eight volunteers signed up to participate

The role of the LAC was to advise the Consultant Team and City Planning staff, and provide feedback on the recommendations and opportunities presented. LAC members were encouraged to participate in discussions with the consultant and to attend the public sessions throughout the study process. A total of seven LAC meetings were held over the course of the Avenue Study, including a charrette and walking tour. At each meeting, presentations were made to the group to facilitate discussion and debate.

We would like to thank the following LAC Members for their interest, participation and dedication:

List of LAC of Members

- | | |
|--------------------|--------------------|
| Bob Amaron | Lauralyn Johnston |
| Cathy Auld | Peter Kostas |
| Susan Bondy | Geri Kozorys-Smith |
| Howard Brown | Lewis Levy |
| Janet Chamberlain | James LeNoury |
| Lisa Cooper | Brian Ludmer |
| Cindy Daly | Selwyn Owen |
| Kenneth Derkach | Julie Patel |
| Bill Dolan | Aviva Pelt |
| Laurie Donze-Allen | Alena Ravens |
| Sander Gladstone | Gerard Ronan |
| Barry Goodman | Sabina Rotenberg |
| Charleen Gorbet | Larissa Stefurak |
| Martin Hofmann | Gerda R. Wekerle |

A special thank-you to York students and area residents Lauralyn Johnston and Aviva Pelt for their support and interest during the study and for their work on the retail study contained in Section 2.2.8.

While many of the recommendations contained within this document represent recommendations either stemming from LAC discussions or endorsed by the LAC, some recommendations do not represent full LAC consensus.



The consultant team led a visioning workshop with the LAC and City staff.



Consultant team leading a site visit and meetings with LAC members.

1.4 Study Components

In each of the City of Toronto Avenues Studies, community design exercises have resulted in necessary improvements and recommendations for revisions to zoning and design guidelines that define the desired scale and character of future buildings. An important emerging issue included the massing of new buildings and how they should address the street and the transition between buildings on the Avenues and adjacent low-rise residential areas.

The outcomes of the Avenue Road Avenue Study will be included as an appendix to the City staff's implementation report that will be presented to Council. Components of the study include:

- Recommended building heights, massing, setbacks and setbacks (i.e. at the street wall and transitioning to neighbourhoods);
- Identification of opportunities to integrate open and green space (that will assist in prioritizing public spending to obtain needed community facilities such as parks);
- Development of guidelines for the public and private realm; and
- Recommended implementation strategies for the City to enact (i.e. amend the City's Sign By-law, Official Plan amendment for the Douglas Greenbelt, etc.).



Like many main streets in Toronto, retail uses line the street at-grade, with residential uses above.



Avenue Road has the advantage of wide main street sidewalks.

2 | existing conditions

2.1 Study Framework

The following documents form the basis of the consultants' policy background for the Avenue Road Avenue Study:

2.1.1 Previous Official Plan

The former North York Official Plan encouraged redevelopment and intensification along Avenue Road. It was designated an Arterial Corridor Area allowing buildings of approximately 3 to 6 storeys in height between intersections and up to 9 storeys at key intersections. Mixed land use was encouraged, in particular retail on ground floors with residential above.

Both the Official Plan and Zoning contained maximum Floor Space Index (FSI) limits, which expressed permissible building area as a multiple of the lot area. The FSI number in the Official Plan was generally 2.0 between intersections and 2.5 at key intersections. However, the FSI contained in the implementing Zoning By-law was lower.

The Official Plan and Zoning established a system whereby a developer may automatically build up to the density (FSI) provided for in Zoning, and the additional density provided for in the Official Plan was only available if certain conditions were met, including:

- Submission of a traffic study showing the impact of development on Avenue Road would not result in unacceptable functioning of the arterial;
- Submission of a report proving sufficient wastewater and stormwater sewer capacity;
- Compliance with design guidelines contained in the Official Plan; and
- Site Plan Control Approval for the development.

2.1.2 New Official Plan

When Toronto's new Official Plan came into force, the North York Official Plan was repealed. The new Plan redesignated Avenue Road according to city-wide planning policies but maintains the policy intent for redevelopment and intensification.

Most of Avenue Road in the subject area is designated as *Mixed-Use Area*. Residential areas to the east and west

carry the *Neighbourhoods* designation, as does the west side of Avenue Road from Joicey Boulevard to Ridley Boulevard. North of Ridley Boulevard to Wilson Avenue, the west side of Avenue Road is designated as *Apartment Neighbourhoods*. The entire length of Avenue Road in the subject area is designated an *Avenue*.

The Official Plan directs that most future growth will occur along the Avenues, as well as Centres and Mixed Use Areas, and be directed outside of *Neighbourhoods* and *Apartment Neighbourhoods*. Both *Mixed Use Areas* and *Avenue* policies facilitate pedestrian and transit-oriented development taking advantage of existing infrastructure. These policies aim to create amenity for adjacent residential areas by promoting ground floor retail along arterials, urban design and safety improvements, while protecting the Avenues from unwanted change. In the new policy framework the Official Plan focuses on a big picture of city growth and leaves specific density (FSI) numbers and other more specific criteria to be contained in the Zoning By-law. The Official Plan also calls for Avenue Studies, such as the current study, to develop more detailed policies for specific Avenue segments and to update Zoning to reflect desired outcomes. These studies recognize there is no single solution for the Avenues and that recommendations will be area-specific.

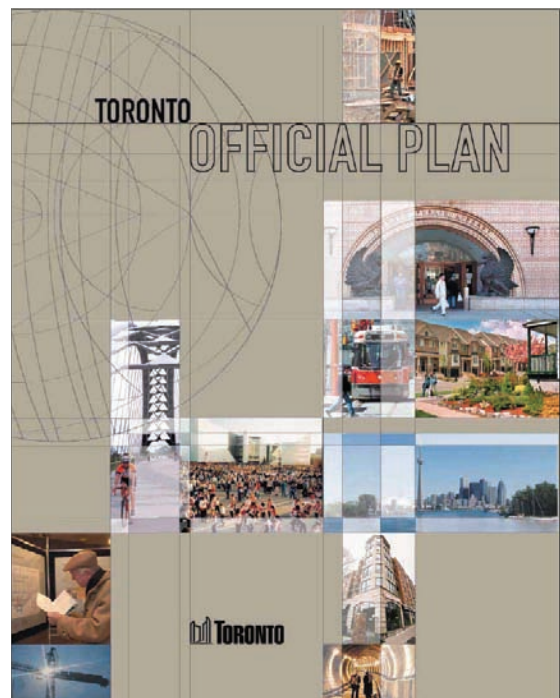

City of Toronto Official Plan.

2.1.3 Existing Zoning

The current Zoning is a remnant zoning that reflects the former North York Official Plan. Most properties fronting Avenue Road are Zoned “C1-General Commercial” allowing for buildings up to 1.0 FSI. To attain the higher FSI and building heights provided for in the former Official Plan owners would have to provide studies and meet criteria outlined in that Plan. Since the old Official Plan is now repealed, this two-tiered approach to development permissions no longer works as intended and needs to be reviewed within the context of this study.

The “C1-General Commercial” zone allows for mixed-use development including buildings with retail at-grade and residential units above to a maximum of 3 storeys. The Zoning also contains restrictions on commercial area within mixed-use buildings, and requirements for building setbacks and lot coverage.

Exceptions to the C1 zone include the apartment complex on the east side of Avenue Road between Douglas and Woburn Avenues (zoned for multifamily dwellings), and the east side of Avenue Road north of Carmichael Avenue (zoned for single-family detached and multifamily dwellings).

Approximately 44% of all buildings on Avenue Road are in excess of the current 1.0 FSI limit, and as such, it is not considered an appropriate or defensible zoning and does not facilitate as of right intensification anticipated in the Official Plan.

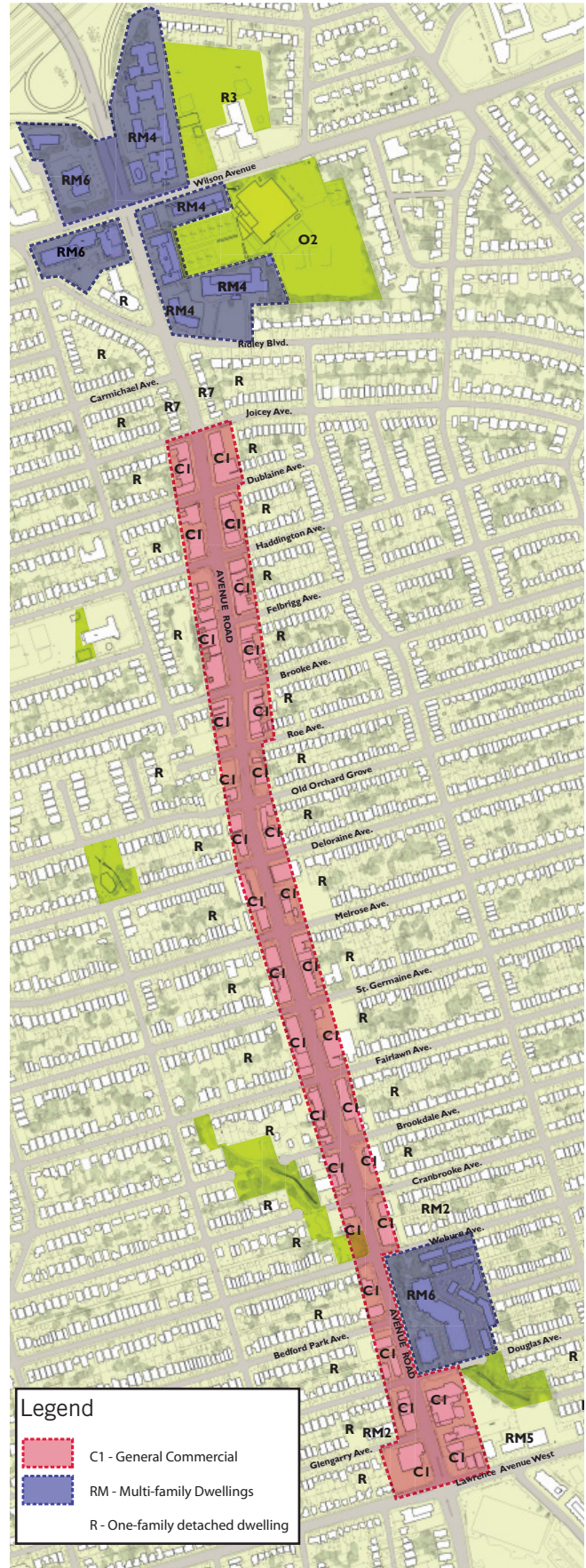

2 existing conditions

2.2 Area Conditions

Each Avenue in the City has different capacities to support intensification and a variety of appropriate built form. In some respects this segment of Avenue Road makes for an unusual Avenue Study:

- It is a relatively healthy main street with a variety of stores and services;
- Wide sidewalks created by setbacks (primarily north of Melrose Avenue) with the sidewalk and setback designed as a cohesive boulevard, which contributes to a pedestrian-friendly streetscape;
- Parking lay-bys provide street parking but take pedestrian space from the sidewalk, particularly south of St. Germain Avenue, where no setback exists;
- It is not a distressed area in dire need of reurbanization;
- There are a limited number of large consolidated land parcels that are suitable for redevelopment in the short to medium term. It is expected that growth will be gradual and limited;
- Streetscape reconstruction on the boulevard has already been completed - this was scheduled prior to the Avenue Study commencing. Given the poor condition of the sidewalk, the decision was made to go forward with reconstruction. Improvements were made above and beyond standard reconstruction (adding over 30 new trees, new decorative paving, decorative banding at intersections with lights and crosswalks).
- The study makes some additional streetscape recommendations such as locations for new street furniture (transit shelters, garbage receptacles, benches) and opportunities for more green open space on the Avenue for pedestrians; and
- The study recognizes sites within the Study Area that have changes in grade (particularly on the west side of Avenue Road), and recommends that developments on these sites explore ways to work with the topography to create an appropriate transition towards the neighbourhoods.



Aerial photograph of Avenue Road taken in 1959.

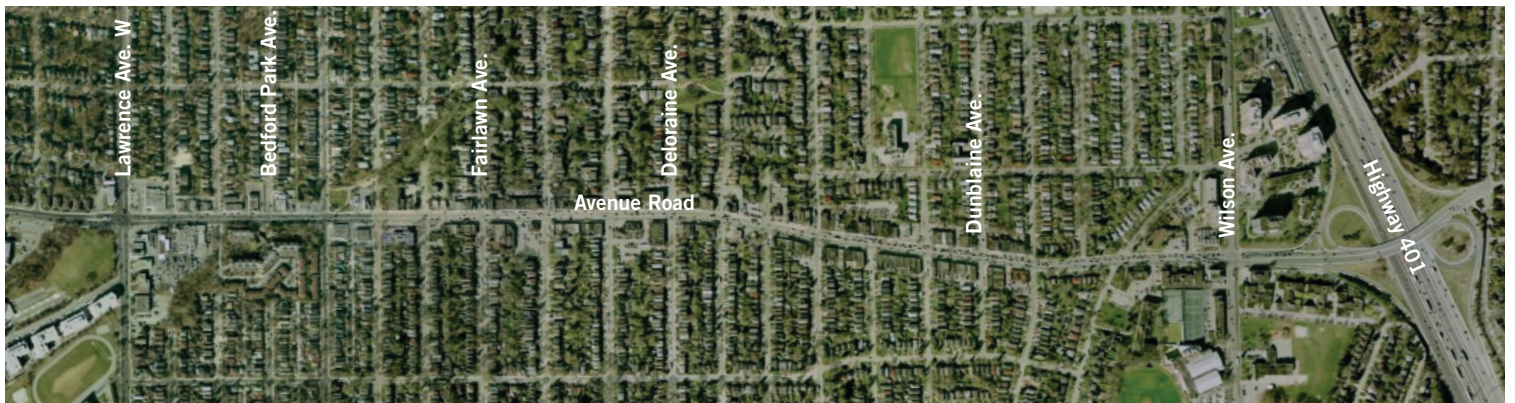

Aerial photograph of Avenue Road taken in 2007 indicating that the Avenue has changed little over the past 50 years.

2.2.1 Predominant Building Uses & Characteristics

The diversity of Avenue Road creates a unique retail street, and shares many characteristics with other retail-oriented streets in Toronto. The street is comprised of mostly one and two-storey commercial buildings that are built to the front property line with retail on the ground floor and residential or small offices above. Avenue Road is bordered by thriving residential neighbourhoods to the east and west – Bedford Park to the east and Ledbury to the west.

Just as the dominant use varies from one end of the street to the other, the heights and built form varies as well. At the north end closer to Highway 401, there are a number of taller residential buildings, some up to 20-storeys. Smaller-

scale residential apartments create a transition from Wilson Avenue down towards Ridley Boulevard. The area between Ridley and Joicey Boulevards, consists largely of one and two-storey single family houses. Between Joicey Boulevard and Deloraine, the commercial main street is consistent on both sides of Avenue Road, and the front setback that exists north of Melrose Avenue creates a comfortable pedestrian realm. The southern section of the street is characterized by much weaker street edge conditions, where buildings are setback from the street with parking between the sidewalk and the building. This form of development is less urban and does not encourage pedestrian activity. Frequent curb-cuts also make this section more prone to pedestrian-vehicular conflict.

Character Areas along Avenue Road

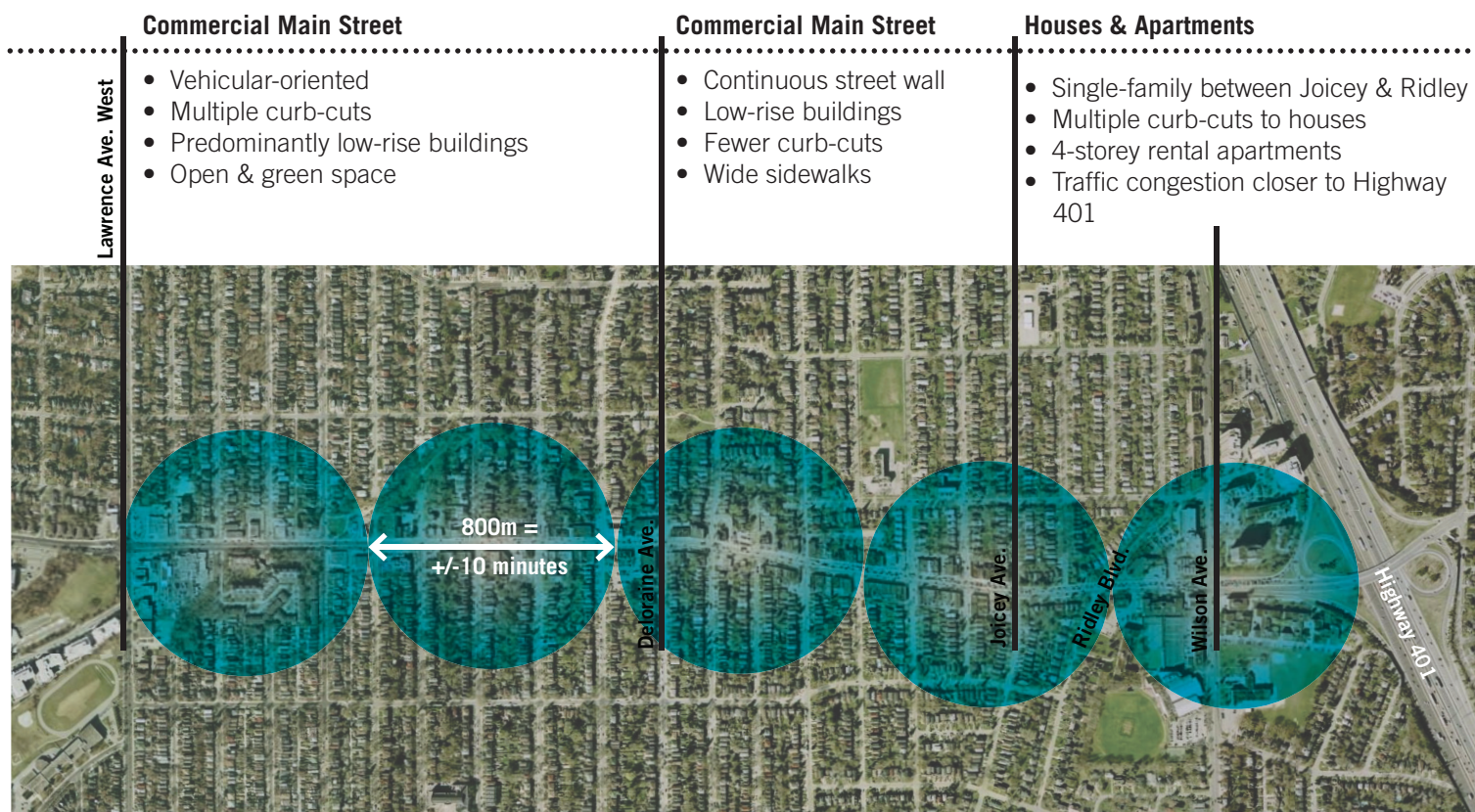

Walking radius of 800 metres indicates a walking time of approximately 10 minutes.

2 existing conditions

The general existing conditions and character of Avenue Road include:

- The southern part of the study area is characterized by the predominance of surface parking and parking next to the sidewalk contributing to a more suburban character;
- The northern and central part of the study area are characterized by main street retail, with a setback to provide widened sidewalks north of Melrose Avenue;
- Many existing buildings have of low architectural value and there are single storey throughout the Avenue;
- Continuous retail frontage exists in most blocks comprised of mostly one and two-storey retail and commercial façades; and
- The north end consists of mostly residential fabric, with single-family residential, apartments and community services.

There is some diversity of building heights along Avenue Road. Between Lawrence Avenue West and Wilson Avenue, this segment measures just under two-kilometres end to end (for a total of under four-kilometres frontage). Within that distance the following mix of building heights are found.

- 32% of this frontage is occupied by one (1) storey buildings
- 50% of this frontage is occupied by two (2) storey buildings
- < 1% of this frontage is occupied by three (3) storey buildings
- 12% of this frontage is occupied by four (4) storey buildings
- 6% of this frontage is occupied by five (5+) storey buildings and above





Ridley Avenue to Wilson Avenue on the west side.



Dunblaine Avenue to Haddington Avenue on the west side.



Felbrigg Avenue to Haddington Avenue on the east side.

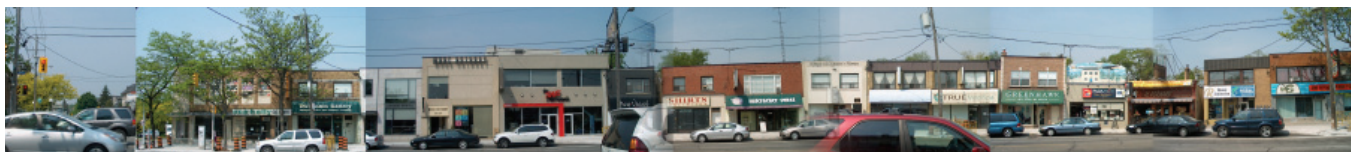

Brooke Avenue to Haddington Avenue on the west side.



Deloraine Avenue to St. Germain Avenue on the east side.



St. Germain Avenue to Brookdale Avenue on the east side.



Cranbrooke Avenue to Fairlawn Avenue on the west side.

2 | existing conditions

2.2.2 Parks & Open Spaces

There are very few public green or open spaces fronting Avenue Road. The east side is particularly lacking in public open space with no neighbourhood parks to the east. The only public park accessed directly from Avenue Road is Brookdale Park and the connected ravine, which can be accessed from the corner of Woburn Avenue and Brookdale Avenue. The increased front setback implemented north of Melrose Avenue, provides a widened public sidewalk cafes, outdoor displays and walking.

This study considers opportunities to create public space in the form of small “pocket” parkettes or other forms of open space.

The Douglas Greenbelt is located at the northeast corner of Avenue Road and Lawrence Avenue, and is currently underutilized and difficult to access. The Douglas Greenbelt is part of Toronto’s larger natural system that connects to the Don Valley. The current configuration of the Douglas Greenbelt is cut-off from Lawrence Avenue because of a private parking lot that blocks access. Students from the schools on the south side of Lawrence often use the Greenbelt and cut through the private parking lot to get to Lawrence Avenue West.



Brookdale Park is located west of Avenue between Fairlawn Avenue and Woburn Avenue, with park frontage on Avenue Road.

2.2.3 Community Services & Facilities

The boundary of the community services and facilities analysis is larger than the Avenue Road Avenue Study area. This occurs because the catchment area for community services and facilities differs between the various service providers. The area for the community services and facilities analysis has been defined as: Highway 401 to the north, Yonge Street to the east, Eglinton Avenue West to the south and Bathurst Street to the west.

A. Schools

There are a total of nine elementary and five secondary schools located within the study area, with a total of 4,087 elementary and 3,063 secondary pupil places. Enrolments from the 2006/07 academic year and the capacities for each facility is described below.

Toronto District School Board (TDSB)

The TDSB elementary school facilities are at 96% of total capacity, and the secondary panel is at 96.5%. The elementary schools are full in terms of eligibility for provincial funding but most have capacity for additional enrolment. There are 3 secondary schools outside of the Avenue Study area and 2 are full, in part because of a lottery for students. The other, Sir Sanford Fleming, has significant capacity for enrolment.

Toronto Catholic District School Board (TCDSB)

The TCDSB is experiencing over-enrolment in both panels: elementary school facilities are at 150% of total capacity and the secondary panel is over-enrolled by 135%. School board personnel report that all four of the schools are available for community use after school hours, and are used extensively for public assembly and various types of community programming. There is limited capacity within the TCDSB’s local schools for new growth however school board staff has indicated that a moderate increase in child population could be accommodated over time. In addition, there are a number of students enrolled in these facilities that are from out-of-district. If enrolment pressures do not abate, the placement of on-site portables and/or realignment of school attendance boundaries will have to be considered.

It should also be noted that there are several private schools serving both elementary and secondary students located within the study area.

The increased demand generated from the estimated 540 additional units (refer to Section 3.6.5) contemplated as part of the Avenue Study will result in approximately fifty students. The local boards of education have indicated that they will accommodate this increase through changes to programs, attendance boundaries and the possible placement of portable classrooms.

B. Libraries

The area is served by three local library branches and two regional branches in which a variety of community programming is provided. The Barbara Frum branch technically falls outside of the defined study area, but due to its proximity has been included. The area is generally well-served by libraries however, some of the branches are in need facility improvements in order to enhance access to community meeting and program rooms.

C. Licensed Daycare

The area is served by a total of twenty licensed daycare facilities offering a total of 1,237 spaces. The information regarding enrolments is accurate as of November 28, 2007. These figures are up-dated daily, and can be obtained from the City's Children's Services web-site. As

of the date the information was compiled, there were only fourteen vacant spaces (or 1% of the total). Therefore, the ability of existing service providers to accommodate additional population growth is constrained.

D. Community and Recreation Centres

Residents of the study area have access to a variety of public recreation facilities, including indoor and outdoor pools, skating rinks, gyms and program rooms.

E. Summary

The study area is a mature community that is supported by a range of community service providers, in a variety of facilities. The area is undergoing incremental change, which over time will impact the availability of existing services. Proposals for new residential development should be accompanied by on-going assessments of local agencies' and boards' ability to accommodate additional demand, and the improvements needed to meet it. In particular, school and daycare centre capacities need to be monitored.

Please see Appendix B - Community Services and Facilities Assessment for the full report.

Toronto District School Board (TDSB)

School	Address	Enrolment	Capacity
Elementary			
Allenby	391 St. Clements Avenue	578	633
North Preparatory	1100 Spadina Road	192.5	210
Armour Heights	148 Wilson Avenue	323.5	305
Glenview	401 Rosewell Avenue	592	501
John Ross Robertson	130 Glengrove Avenue West	512.5	536
John Wanless	245 Fairlawn Avenue	602	670
Ledbury Park	95 Falkirk Street	441.5	498
Secondary			
Forest Hill CI	730 Eglinton Avenue West	875.98	732
Lawrence Park	125 Chatsworth Avenue	977.51	882
Sir Sanford Fleming	50 Ameer Avenue	401	723

Toronto Catholic District School Board (TCDSB)

Elementary			
Blessed Sacrament	24 Bedford Park Avenue	521.5	446
St. Margaret	85 Carmichael Avenue	577.8	288
Secondary			
Loretto Abbey	151 Rosemount Avenue	953	480
Marshall McLuhan	1107 Avenue Road	1001.7	969

2 | existing conditions

2.2.4 Vehicular Circulation



Avenue Road is a major arterial road that connects to downtown Toronto.

Avenue Road is a major arterial road. The road serves the businesses and residences that front it and also provides immediate access to the adjacent residential neighbourhoods. It provides a direct connection to Highway 401 at the north (where Avenue Road terminates) and extends as a primary route south towards downtown. In addition to serving automobile and truck traffic, it is also a major transit corridor served by bus routes. Its configuration (on street parking provisions, number of available traffic lanes and centre turning lane) serves travel demands fairly well.

Avenue Road, like all other arterial roads in Toronto, accommodates high traffic flows during the typical weekday rush hour periods. The traffic flows are accommodated at reasonable levels of service. Delays often occur due to vehicles making left turns onto the side streets and surface parking lots. This is similar to many other arterials in the city.



Avenue Road is well-served with short-term parking with bump-outs that provide all-day metered street parking.

In the north end, between Joicey Boulevard and Ridley Boulevard, there are a number of single-family houses, each with their own driveway and curb-cut, which impedes pedestrian flow. Access to Avenue Road from these driveways is difficult during rush hour.

In the commercial-retail areas along Avenue Road, there are very few blocks with rear laneways and requires that the servicing of retail stores to be done from Avenue Road, which in some instances, particularly early morning servicing, can take place in the on-street parking bump-outs.



Avenue Road, like all other arterial roads in Toronto, accommodates high traffic flows during the typical weekday rush hour periods.

2.2.5 Transit

Avenue Road is well served by transit. Two bus routes operate on Avenue Road. Route 61 operates from Bombay Avenue just north of Highway 401 to the Eglinton Avenue Subway Station. Route 142 operates from Bombay Avenue directly to downtown Toronto. Route 142 also provides an express bus service during the weekday peak periods of travel.

Bus service on Avenue Road also has the ability to easily serve increases in transit travel demand as they arise. However, traffic modal split on Avenue Road shows a higher usage of private vehicles, and low transit use.

A few of the bus stops along this section of Avenue Road have enclosed shelters, but most are not sheltered and only served by a bench and signage. When the City implements its coordinated street furniture program, additional stops along Avenue Road should be provided with enclosed transit shelters.

2.2.6 Parking

Avenue Road is better served for long and short-term parking than many other arterials in the City. The reconfigured and reconstructed road includes bump-outs that allow for all-day parking rather than only off-peak hour parking. These parking spaces are useful from both a vehicular and pedestrian perspective, as the on-street parking creates a buffer between the sidewalks and the busy roadway. The parking bump-outs also create larger pockets for locating pedestrian amenities such as seating, bike parking and planters.

Most larger retailers along the Avenue provide surface parking lots, while others provide a few parking spaces on a shared rear laneway. There are two TPA/Green P lots, one at the southwest corner of Avenue Road and Roe Avenue and another larger lot on the west side, just north of Brooke Avenue.

The predominance of surface parking, particularly in the southern section of the study area creates a more suburban and less pedestrian-friendly street. Parking between the sidewalk and buildings detracts from the pedestrian realm and contributes to the impression of a very wide, busy street.



Avenue Road has good transit service with two bus routes: Route 61, 142, and 142 express.

2 | existing conditions

2.2.7 Larger Sites - Opportunity Sites

As part of this process, nine sites were analyzed to determine reasonable redevelopment potential for the Avenue. The purpose of this was to anticipate future sites that, due to their location, tenure and size, could potentially be developed in the foreseeable future. The pace of development on Avenue Road has been moderate and the expectation that all of these sites will develop, even over the medium timeframe is unlikely.

The larger opportunity sites considered a number of criteria, including:

- 1. Lot depth:** An analysis of lot depths, as measured from the front property line along Avenue Road to the rear property line, indicates most lots have a depth ranging between 27 – 37 metres. The consideration for lot depth creates potential for setbacks and transition from the rear-adjacent residential properties. For the purpose of determining the larger sites, lots with a depth at or in excess of 37 metres would be considered. There were a number of larger sites that were wider than average, but shallower, and were not considered as appropriate for increased height, as setbacks and stepbacks would not provide for buildable or feasible floorplates.
- 2. Lot ownership:** The ownership and possibility for consolidation was investigated for lots that met the criteria for lot depth. The possibility of one or two consolidations was considered feasible and therefore included in the potential opportunity sites. Smaller lots, or typical retail storefronts of approximately 6 – 10 metres in width, were not considered for consolidation as the feasibility of purchasing more than three or four lots and consolidating was deemed financially unlikely.
- 3. Likelihood of current use being redeveloped:** The gas stations were not considered as they are difficult to redevelop because of environmental concerns, and the economic value of these highway oriented locations. Pusateri's grocery store, as it is actively used by the immediate and farther-reaching community was also not considered.
- 4. Current plans for redevelopment:** Sites such as the northwest corner of Avenue Road and Lawrence Avenue and the "Palma Brava" site, north of Deloraine Avenue, were not considered as they are currently under construction and will likely retain their proposed use for the next few decades.

From these considerations, nine opportunity sites were chosen (see map). This represents a limited number of large consolidated land parcels that are suitable for redevelopment through the length of this two-kilometre road.

This study does recognize that there is potential for other sites to be redeveloped in the short-term, but due to existing ownership patterns and the difficulty of assembly for additional redevelopment sites, it is more likely that redevelopment will occur on the larger opportunity sites.



Site 5: Bruno's



Site 4: McDonald's

Site 6: No Frills



Site 3: NW corner of Brookdale Site 7: TD Bank



Site 8: Nissan Dealership

Site 9: Royal Bank/Shopper's



Site 1: The Beer Store.

Site 2: KFC

Nine larger opportunity sites

2 existing conditions

2.2.8 Retail Study

A Retail Study was conducted to provide information to the Local Advisory Committee (LAC) regarding the nature of the retail strip on Avenue Road between Lawrence Avenue West and Wilson Avenue. The LAC determined that a survey should be done to gather information from the local merchants to recognize their concerns. The intent of the survey was to reach out to the merchants of the area and assess their perceptions and needs regarding design guidelines and options for future intensification.

The City of Toronto Planning Division designed an in-person survey to be administered by staff and graduate planning students from York University. The survey consisted of 25 questions and was undertaken with owners or managers of first floor commercial retail stores on or adjacent to Avenue Road. A majority of the surveys were completed between July and August 2007, while the remainder were mailed or faxed back to the City of Toronto for a completed total of 137.

Of the commercial types on the Avenue Road strip, 77% is some form of retail, the remainder being made up of food, business, beauty and health services.

While the mean of commercial space is 500 to 1000 square feet there are still a considerable number of much larger stores including at least 10 of over 5000 square feet. 80% of the merchants surveyed rent their commercial space. The majority of merchants have been on Avenue Road for over 5 years, with over 35 merchants who have been retailers on the strip for over 20 years. There are 711 full-time employees and 477 part-time employees on the retail strip from the 137 surveys received.

The high propensity for merchants to be renters may mean they have a lower level of investment in the character of the street in the sense of property values, yet, they have a high interest in making the street amenable to their customer base. They are often concerned with the transit service in the area for themselves and their employees. The considerable employment in the area leads us to believe that many of the people serviced by the area are also employed in the area.

The second section of the survey dealt with what the merchants feel the conditions of their current businesses are.

65% of merchants believe that over half of their client base is local - from the area bounded by Glengrove Avenue to Wilson Avenue and Bathurst Street to Yonge Street. Over 117 merchants believe that the majority of their customers drive to their stores. 'Walk' is the second most commonly cited mode of arrival with 'transit' and 'bike' being less used alternatives. While car is the most common mode, the combination of other modes are more frequent than driving.

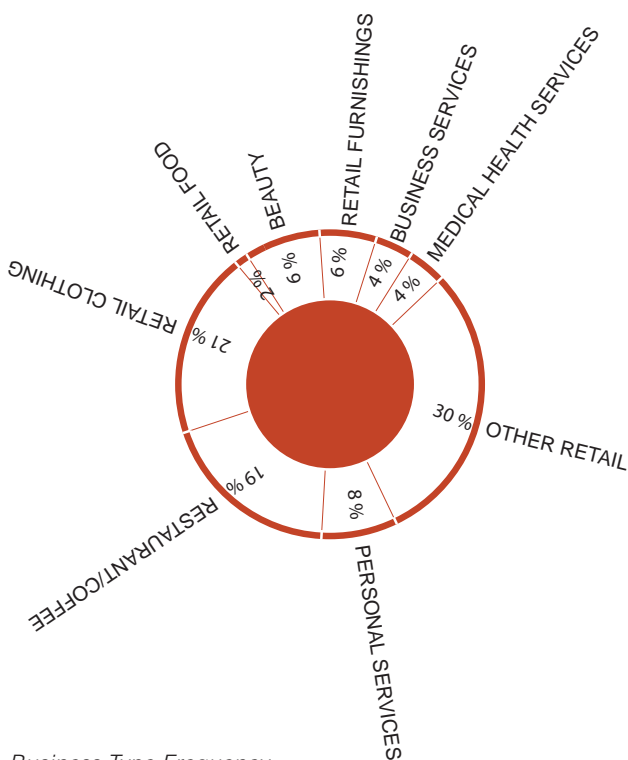

Business Type Frequency

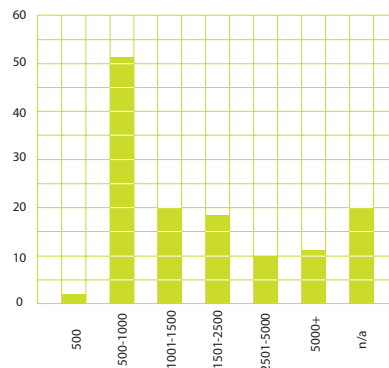

Average size of available commercial space on Avenue Road

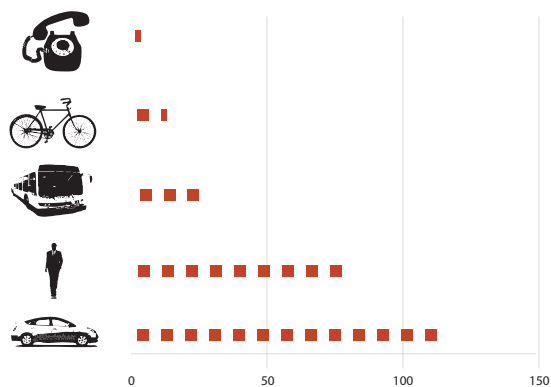

Mode of arrival to store as indicated by merchant. The majority of customers are arriving by car

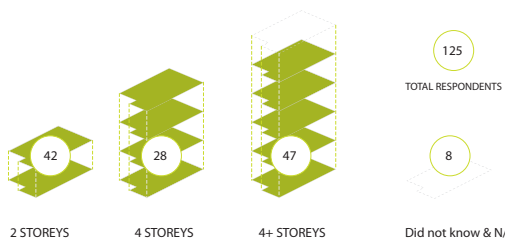

Business owners response to the preferred height of new development at the sidewalk

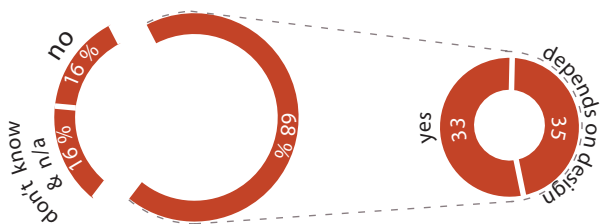

Business owners response to the development of larger lots at 5 - 7 storeys

One-third of those surveyed felt their business volume was the same as last year, a third felt business was down and a third felt business was up over last year. 16% stated that they were considering expanding their business on Avenue Road and only 6% were thinking of relocating from the Avenue. This indicates that the Avenue Road area is a stable retail environment at the moment. Sales may have been affected by the road construction that had been ongoing for the better part of the last two years.

The merchants were also asked questions regarding building heights, street amenities and other concerns that were raised by residents and at the Local Advisory Committee meetings.. These are the results:

Building heights:

While 34% of the merchants surveyed would like to see 2-storey development at the sidewalk on Avenue Road; 22% would like to see 4-storey development at the sidewalk and 36% would like to see more than four storey buildings. On the larger and deeper consolidated lots, 68% of merchants would favour buildings of five to seven storey heights with 35% of them in favour dependant on the design.

Many merchants see the development of the area as an opportunity for a flourishing retail environment. While many like the 'village' character of the area, many see appropriate development, in particular of the larger lots, as a way to increase pedestrianization of Avenue Road and their customer base in the area.

51% of merchants do not favour more billboards on the strip. This could be related to the fact that 80% of merchants rent their commercial space and would not receive revenue from the rental of the media space.

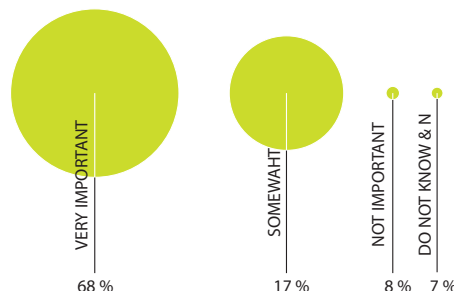

Merchants are generally in favour of implementing green building standards

2 existing conditions

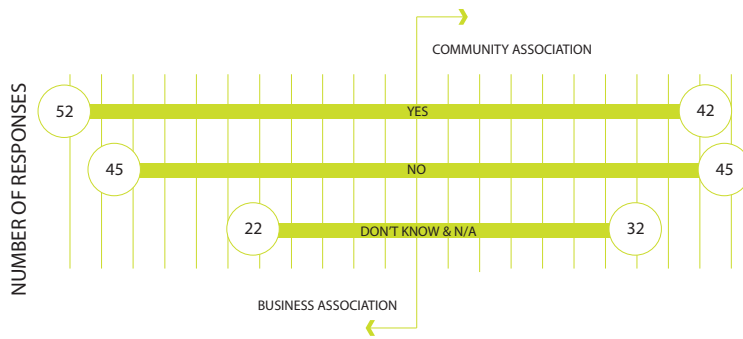

Support for Community or Business Association

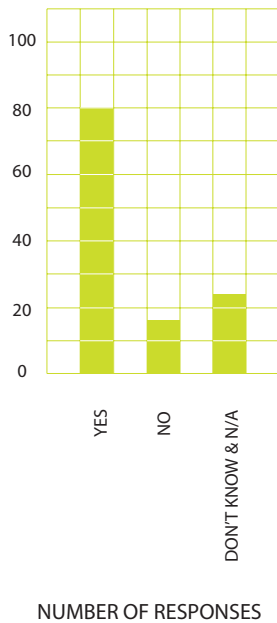

Neighbourhood Brand Concept - Merchants were in support of creating a distinct identity for the area. The Upper Avenue was generally regarded as a good name for the area.

Most would like to see new development meet “Green Building Standards” for energy and water conservation. An overwhelming majority of those surveyed favour the concept of a Neighbourhood Brand such as the “Upper Avenue”.

There does not seem to be sufficient support for a community or business association as the number of the people who “don’t know” and the number of negative responses outweighs the positive interest to create these associations. Many of the retailers, when informally asked, stated that they do not have the time to participate on a regular basis in such forums. However, a contact list has been compiled for those who have expressed interest in such an endeavour, as those who were positively inclined were quite enthusiastic about participating in either a community or business association.

Merchants see the street’s amenity as a favourable characteristic of their business. They see the advantages as being:

- Good community (23)
- Clientele (23)
- Exposure (15)
- Type of retail (12)
- Specific Location/Access to 401 (11)

However, they mention as disadvantages:

- Parking (40+ mentions)
- Construction
- Traffic (too loud/fast)
- Not enough walking traffic

The LAC generated a list of improvements for the street. When asked to rate this list, the merchants overwhelmingly prioritized parking as an essential improvement. 87 merchants listed parking as “first”, and 20 responses for “second”. There is an abundance of short-term parking in the area, but many business owners acknowledge that customers are not likely to walk long distances between their cars and a single retailer.

Benches and garbage cans was mentioned over 20 times in each of the first, second and third categories. Transit service, trees and green-space were also listed frequently with numerous mentions as the second, third and fourth

in the scale of importance. Signage improvements, bicycle parking and public art were also mentioned but less important.

The merchants recommended other possible ways that their business could be improved:

- Parking – free, cheaper, less enforced (31 responses)
- Beautification (26)
- Street Furniture (14)
- BIA/CIP (12)
- Greenspace/Public Space (14)

There is a perception among the merchants that there is a lack of parking along the retail strip of Avenue Road. The merchants also complain that parking on the northern portion of the retail strip is too strictly enforced. They feel that consumer traffic is negatively affected due to stringent ticketing practices in the area.

Many of the suggestions and recommendations cited by merchants are often the purview of Business Improvement Associations or Community Improvement Initiatives and are not undertaken by the City of Toronto. However, many of the ideas put forth could be incorporated through urban design measures and zoning specification for future development or intensification on Avenue Road.

In conclusion, the survey revealed that the merchants of Avenue Road enjoy a stable retail environment that is enhanced by the adjacent residential communities. Many of them support some intensification as a strategy towards expanding their customer base. They also greatly support initiatives that will increase pedestrian amenity and ‘street life’ as they feel this would support their walk-in traffic customer base. While parking was the most often noted issue, many other initiatives suggested by the LAC and the City of Toronto were also recognized as being important to the on-going health of the retail environment.



Merchants response to the desired improvements for Avenue Road

3 recommendations

3.1 Study Vision

The following study vision was created through feedback at the public Open Houses, Ratepayer’s Vision Statement, and through numerous discussions with the LAC:

“The Upper Avenue will reflect an open, bright, people-friendly environment, framed by green areas and buildings of appropriate scale, safe for young and old alike, nurturing pedestrian traffic day and night, minimizing intrusion of vehicular traffic into adjoining residential streets, alive with commerce, the dynamic core of a thriving neighbourhood and gateway to Toronto.”

3.2 Guiding Principles

Based on input from the public open houses and the LAC, the following guiding principles were developed:

- 1 *Maintain the village atmosphere by ensuring that redevelopment and public realm improvements contribute to a more walkable Avenue Road.*
- 2 *Encourage vibrancy through a mix of uses – with retail-oriented uses at grade and a mix of retail, commercial and residential throughout the Avenue.*
- 3 *Maximize opportunities for greening the street through the private and public investment, including “green buildings”, new parks and open spaces.*
- 4 *Build on corridor identity – through naming the Upper Avenue, introduction of gateways, public art, signage, street furniture, etc.*
- 5 *Encourage revitalization with high-quality development of a modest scale.*



Active retail frontages and outdoor amenity space combined with wide sidewalks make for a vibrant public realm.

High quality mid-rise, mixed-use buildings will integrate with the existing built fabric of Avenue Road.

3 recommendations

3.3 Greening the Avenue

As indicated in Section 2.2.2, the study area and surrounding neighborhoods are deficient in parks and open spaces. To help address the low provision of local parks, City Council has recognized the deficiency and has designated the area as a priority area in the new Parks By-law where a higher alternate parks dedication rate will be levied. For sites less than one hectare the parks levy will increase from 2 to 5% of the lot value to 10% of the lot value.



Site 1: Roe TTC loop.



Site 2: Dunblaine Avenue.



Greening of the Avenue can happen in a number of ways - including planters, parkettes and plazas.

3.3.1 New Parks & Open Spaces

City owned lands will be the first priority for developing new parks and open spaces. By considering publicly owned lands first, the possibility for more immediate development will be the most realistic. There are two key areas that were considered in this context, including the Toronto Transit Commission (TTC) bus turn-around loop and the public right-of-way of Dunblaine Avenue.

1. **Roe TTC loop:** This property is currently being used infrequently as a turning location for short-turn buses. The property may be declared surplus in the short to medium term. The narrow width and access to this mid-block property make it unsuitable for development. If the lot is declared surplus, it is recommended that the City use the land to create much needed public park space.
2. **Dunblaine Right-of-Way:** Dunblaine Avenue, on the east side of Avenue Road is the only road to end at Elm Road, which is the next north-south residential street to the east. There are approximately 17 - 20

residential properties on Dunblaine Avenue (east of Avenue Road), making it a possible location for closing off vehicular access to Avenue Road and creating a civic space.

Traffic approaching Avenue Road from Dunblaine Avenue on the west side would still be able to turn south or north onto Avenue Road and the traffic signal would continue to provide for pedestrian crossing. Vehicles on the east side of Dunblaine Avenue would access Avenue Road via Joicey Boulevard or Haddington Avenue.

There are several commercial-retail units that front onto Dunblaine Avenue which would also require vehicular access from the rear lane system that runs south from Dunblaine Avenue to Felbrigg Avenue, making access for servicing more convenient. By closing off Dunblaine Avenue a village square or urban plaza could be created where shops can hold outdoor displays or cafes can have terrace space. Few such places currently exist along Avenue Road.



An example of a street closure on Yonge Street at McGill Street.

3 recommendations

3.3.2 Green Fingers

There are a number of other City-owned spaces along the Avenue Road corridor that can be used to create a “greener” Avenue Road. There are many underutilized or “orphaned” spaces within the City right-of-way and between the street and buildings, particularly along the east-west side streets. Depending on the location, a landscaped approach is recommended for improving these spaces.

On the July 12, 2007 site walk with the LAC, twelve spaces were identified for greening, including:

West Side

- SW corner of Bedford Park and Avenue Road
- SW and NW corners of Douglas and Avenue Road
- NW corner of Cranbrooke and Avenue Road
- SW and NW corners Brookdale and Avenue Road
- SW corner Roe and Avenue Road
- NW corner Wilson and Avenue Road



Raised and flush planters separating pedestrians from street traffic.

East Side

- NE corner Wilson and Avenue Road
- NE corner Haddington and Avenue Road
- NE and SE corners Felbrigg and Avenue Road
- SE corner Roe
- SE corner Deloraine (beside No Frills)
- NE corner Woburn

Potential designs for the “green fingers” include: raised and flush planters, planted boulevards, low shrub, ground cover, vines, ornamental grasses, perennial or annual flowers or a combination, public art, and seating walls.

The design of these green “fingers” will require future City design work and funding as well as community stewardship. This will likely occur at the time of reconstruction of residential side streets.



Two potential locations for the “green fingers” shown above.

3.3.3 Green Street Medians

In keeping with the priority to develop underutilized public spaces for public use, it is proposed that the City consider building landscaped planters or medians within the existing painted centre median on Avenue Road. A planted median, which would not require total road reconstruction, would create additional green spaces, provide a positive image for Avenue Road and if designed properly, provide refuge for pedestrians crossing the street. Additionally, this would enable the City to prohibit left-turns from the properties fronting onto Avenue Road, thereby decreasing the potential conflict of cars turning onto and off Avenue Road. Due to the short block faces along the street, there already exist more than enough intersections with left turns.



The existing painted centre median of Avenue Road.



A planted median could help to improve the image of Avenue Road.

3.3.4 Green Public Lanes

There are two unpaved lanes between Douglas Avenue, Bedford Park Avenue and Woburn Avenue that connect the west side of Avenue Road with Grey Road to the west. There is potential to close a small portion of these lanes off so that parkettes could be created at their Avenue Road frontage.

As the residential properties on either side of these lanes use these as a means of accessing both Grey Road and Avenue Road, the Grey Road access needs to remain open. Although not all properties have rear-yard parking or garages along these lanes, resident acceptance would be necessary before these lanes could be considered for closure.

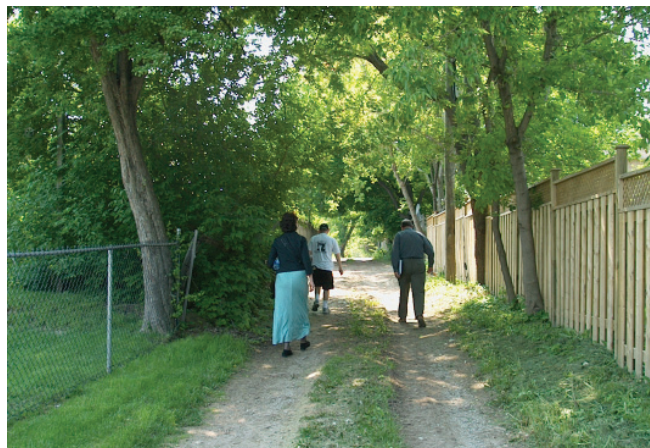

Unpaved public lane between Woburn and Bedford Park Avenue.



Unpaved lane between Douglas and Bedford Park Avenue.

3 recommendations

3.3.5 Douglas Greenbelt

The Douglas Greenbelt is an important natural resource in the area and part of a larger natural system that connects to the Don Valley. This naturalized area is underutilized, inappropriately used and difficult to access. Recommendations for bringing this green space back into use by the local and broader community include:

- 1. Naturalization and improvements to encourage public use:** The ravine should be cleaned-up and re-naturalized. The ravine should be better maintained. By improving maintenance, access and visibility of the Douglas Greenbelt, increased activity can take place, such as dog-walking, neighbourhood short-cuts and recreation, thereby enhancing security. Other improvements that would enhance the park usage include lighting, better paths and railings.
- 2. Douglas Avenue park access:** The visibility of the entrance to the Douglas Greenbelt can be greatly improved by enhancing the Douglas Avenue right-of-way. A more “park-like” street should be created to draw users to the Greenbelt from Avenue Road. By planting trees, locating a sidewalk on the north side of Douglas Avenue and locating a visible park marker or landmark element, the natural park image would extend to the street.
- 3. Public parkette:** The area at the east end of Douglas Avenue is currently underutilized as a public space. Enhancements to this area could help create a park entrance for the Greenbelt. Proposed enhancements

include signage or marker that is visible from Avenue Road, a plaza with seating, landscaping and lighting.

- 4. Reopening of the southern access towards Lawrence:** The proposed re-opening of the ravine at Glengarry Avenue at the south end would allow users of the Greenbelt direct access to Lawrence Avenue. At the time of this report, the City is proceeding to purchase the necessary properties.

The proposed enhancements to the Douglas Greenbelt would result in a considerable natural public green space to be better used by this community.



The Douglas Greenbelt should be improved to encourage use by the community.

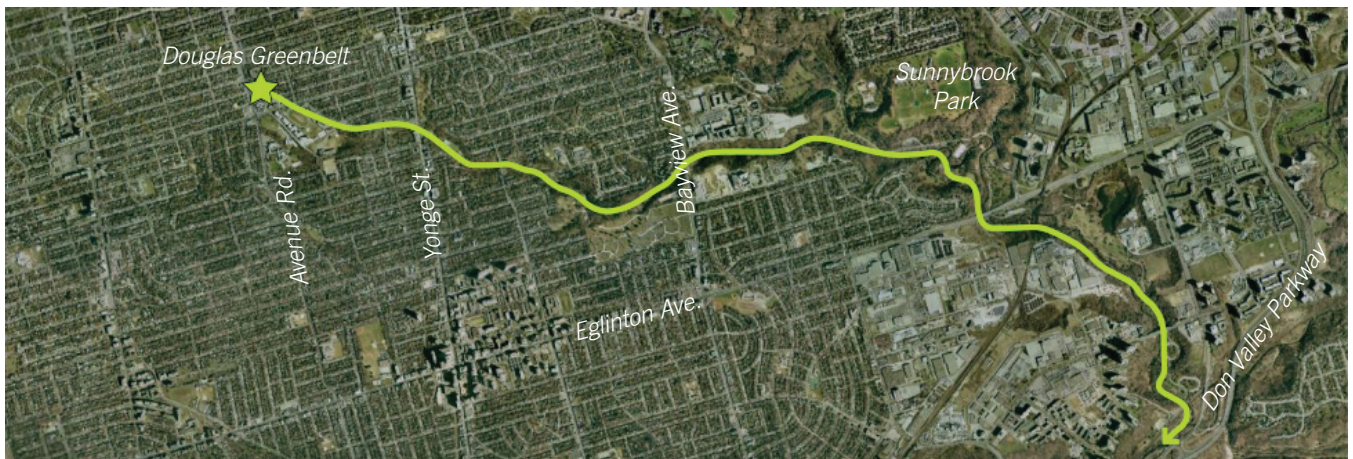

The Douglas Greenbelt can become part of a larger recreational system in the Toronto.



Before: The Douglas Avenue green space would be a better entry area to the ravine.



After: Proposed enhancements include signage or markers that is visible from Avenue Road, a plaza with seating, landscaping and lighting. A marker could denote the entrance to the Greenbelt, making it more visible from Avenue Road.



After: Even a small public open space can become a place for the local community to enjoy.

3 | recommendations

3.3.7 Green Space in New Developments

The June 12, 2007 charrette resulted in a proposal that all new larger developments provide publicly-accessible open or green space. This open space could take several forms. At corner lots, buildings should be sited so as to provide a setback at the corner and/or along the side street frontage to provide areas with seating, public art or other public amenities. On internal block sites a building setback including a forecourt, garden or plaza contiguous to the sidewalk could be provided with public access.

For corner locations, a setback at the corner contiguous to the public sidewalk, public green or open space will be required. This should be implemented through the City's zoning by-law.



Publicly accessible seating and public art at street corner in Little Italy.



Landscaping contiguous to the sidewalk within the front setback.

3.3.8 Green Building Standards

To promote the greening of Avenue Road, green building techniques will be encouraged for all new developments. The City will require new buildings to meet applicable City of Toronto Green Building Standards and will further encourage visible green models, such as planted and usable green roofs.



Terraced green roof design of a commercial building. Green building technologies will be encouraged on Avenue Road.

3.4 Identity of the “Upper Avenue”

During the course of the consultation process and work with the LAC, many participants expressed a desire to promote Avenue Road as a special place with an identity different from other parts of Avenue Road as well as a special location within the City. As a result, it was suggested that a “brand” or new identity for the area be developed. The name “Upper Avenue” was coined and has since been accepted by many community members.

The idea of creating a neighbourhood identity has been implemented in many other Toronto neighbourhoods, for example – “Little Italy”, “The Beaches” and “The Annex”. Branding has many applications for both physical design and marketing. For example, new street furniture could incorporate the name, as well as streets, signs, banners and other street installations. The initiative will require community participation and should be a focus of a newly organized Community Association (see Section 5.2.1). A logo for the “Upper Avenue” could be created by the City in conjunction with the Community Association.



Light installations along College Street.



College Street street sign in Toronto’s Little Italy.

3 recommendations

3.5 Public Realm Amenities

3.5.1 Gateways & Public Art

The City is currently developing a Public Art Master Plan that will identify priority areas for art. Identified locations in the study area should be included in the City's Public Art Master Plan.

Given the prominence of Avenue Road, particularly as a gateway into the City, public art should be considered at key locations, such as the intersections of Avenue Road and Wilson Avenue and Lawrence Avenue. One of the most visible sites is the gateway site of Avenue Road at, and north of Wilson Avenue. Larger-scaled public art installations may be appropriate in this location, due to the vehicular-oriented nature of this part of the street. Other locations for public art include the intersection of Avenue Road and Lawrence Avenue, although the nature of the existing developments (and forthcoming developments) may limit gateway treatments or public art. There are many possible locations for public art along the Avenue Road corridor, particularly where new developments are able to provide new public parkettes, building forecourts, plazas or gardens.

Private developments, particularly the larger developments (over 10,000 s.f.), should contribute public art along Avenue Road.



University of Toronto's Gateway features at College Street and St. George Street.



Public art pieces can bring a sense of intrigue and pleasure to public spaces on Avenue Road.



The Avenue Road and Lawrence Avenue West intersection could enhance its entry role to the "Upper Avenue" through a gateway element that includes seasonal planting, signage or public art.

3.5.2 Coordinated Street Furniture

Currently, the street furniture on this segment of Avenue Road is inconsistent in design, insufficient and visually unattractive. There are too few benches and existing benches are often constructed of plastic material with extensive advertising oriented to passing traffic. Multiple newspaper boxes are not sufficiently grouped. Not all bus stops have shelters and there is a shortage of recycling and litter bins. After the recent reconstruction of the Avenue Road sidewalk the existing street furniture was returned to its former locations.

The City of Toronto has approved a new coordinated street furniture program, contracted with Astral Media Outdoor LP for a period of twenty years. The City and Astral Media will begin to replace all street furniture in 2008, with the exception of litter bins which will start to be replaced in 2009 when the current contract expires. The contract provides for new multi-publication newspaper boxes, transit shelters, benches, litter and recycling bins, information kiosks, public washrooms, community notice boards, outdoor bicycle parking racks and enclosed bicycle storage lockers.



Current conditions and placement of street furniture in the study area.

In July 2007, members of the Local Advisory Committee, the Consultants and City staff conducted a site tour to examine existing street furniture and to make recommendations for the placement of new street furniture on this segment of Avenue Road. It is understood that a site plan would be prepared by the City and Astral Media prior to the installation of street furniture on a particular street, and there would be an opportunity for consultation with local businesses and community groups.

Portions of Avenue Road’s public sidewalk are wider than most ‘Avenues’ in the City. The recessed street parking bays provide a rhythm of narrow sidewalks adjacent to the bays and wider sidewalks between the parking bays. In view of the unique layout of the right-of-way, Avenue Road presents opportunities for the placement of street furniture that may differ from the standard placement guidelines.



Astral Media Outdoor LP’s new street furniture design.

3 recommendations

Recommendations to guide the street furniture placement on Avenue Road:

- At each transit stop group the transit shelter with an interior bench, a multi-publication newspaper box and a litter/recycling bin.
- Where there are wide sidewalks (particularly in the northern portion of the east side of Avenue Road) benches can be placed facing each other perpendicular to the street, particularly between trees, as an alternative to single benches facing the street or the storefronts.
- On sidewalks where limited opportunities exist for the placement of street furniture locate bicycle parking and parking ticket machines on the 'bump-outs' between parking bays. Relocating the bicycle parking and parking ticket dispenser machines to the 'bump-outs' will free up space on the narrower portions of the sidewalks for pedestrians.
- There is no need for information kiosks as this is not an area heavily used by tourists, but there may be opportunities for community information boards.
- Public washrooms are not recommended given the availability of washrooms in coffee shops, restaurants and retail outlets and the amount of sidewalk space they occupy.
- Outdoor bicycle parking is recommended in the 'bump-outs' between parking bays and grouped close to the entrance of surface parking lots. Bicycle storage structures are not recommended on public sidewalks as they occupy too much space, but may be incorporated within public parking lots.
- There are strategic locations for particular pieces of street furniture that would benefit adjacent retail establishments and the public. For example, litter/recycling bins are always welcome on the sidewalk near take-out restaurants and groupings of benches are welcome near coffee shops and ice-cream parlours.
- Wherever possible, transit shelters, litter/recycling bins and benches should be branded with the 'Upper Avenue' logo.

Because this is a flourishing pedestrian-oriented commercial 'Avenue', it is recommended that this segment of Avenue Road be considered as a priority area for the early installation of the new coordinated street furniture. It is also recommended that the plan for street furniture placement be reviewed with the Community Association and residents associations in the study area and any business associations that may exist at that time.



Astral Media Outdoor LP's new bus shelter design.

3.5.3 Rooftop Billboards

There are currently 19 locations with rooftop billboards on Avenue Road between Lawrence Avenue and Wilson Avenue. Some of these have multiple back-to-back installations. There is a concentration of billboards on this Avenue segment because of the low scale of the commercial buildings, the heavy traffic on Avenue Road and the scarcity of alternative commercial rooftop sign opportunities on Avenue Road between Lawrence Avenue and downtown. This concentration of rooftop billboards detracts from the amenity of the streetscape and both the merchants surveyed and the members of the Local Advisory Committee did not wish to see additional rooftop billboards erected.

The sign by-law for the former City of North York, By-law 30788, requires that rooftop billboards be at least 153 metres (500 feet) away from each other. Even if all 19 rooftop billboard locations are legal, there would be room for approximately 5 more rooftop billboards to be erected as-of-right. To date the City has only found records of 10 permits for the 19 billboard locations and the status of the other 9 needs to be clarified.

Given the existing concentration of rooftop billboards and the desire to improve the visual attractiveness of the streetscape, it is recommended that By-law 30788 be amended to prohibit the erection of additional rooftop billboards on the portion of Avenue Road between Lawrence Avenue and Wilson Avenue.

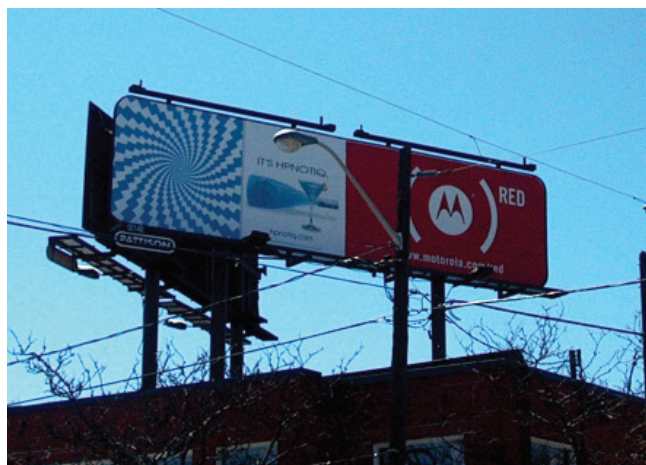

The construction of rooftop billboards along Avenue Road detract from the streetscape amenity.

3 recommendations

3.6 Built Form Recommendations

Section 3.1.2 of The Toronto Official Plan states that “new development will be massed to fit harmoniously into its surroundings and will respect and improve the local scale and character.” As an important component of this Avenue Study, the built form recommendations will ensure that new developments will:

1. Be compatible with existing built form and of an appropriate scale;
2. Contribute to a comfortable pedestrian realm; and
3. Have no adverse impacts on adjacent residential *Neighbourhoods* (as designated in the Official Plan).
4. Be of a high quality that supports the character and function of Avenue Road.

The following principles were developed to guide new development:

- Preserve an appropriate amount of sunlight throughout the day;
- Maintain minimum sidewalk widths;
- Preserve a pedestrian sense of scale, by balancing the width of the street and height of new buildings;
- Establish a minimum 2-storey street wall;
- Reference the existing and historic form of buildings on Avenue Road through a stepback above a 2-storey podium at the street to help maintain a village atmosphere; and
- Prohibit parking between the City right-of-way and the building to create a continuous streetwall necessary for an urban condition.

3.6.1 Height & Massing Principles for Base Condition

The following recommendations should guide future development on the Avenue and are based on a series of analyses including the review of existing zoning, shadow studies, massing models and realistic building simulations.

- New infill buildings should respect and be compatible with the existing massing and heights and the existing streetscape. Along the length of Avenue Road, a minimum of two to a maximum of five-storeys

is recommended, subject to exceptions noted in Section 3.5.2. - Height & Massing principles for larger opportunity sites.

- The considerations for the base condition were based on a feasible model of development suitable for lot depths of 27 – 37 metres. In addition to the principles outlined above, the commonly applied 45° visual angular plane was also considered in the development of the base condition. Typically, the visual angular plane is taken from the opposite sidewalk or right-of-way. On Avenue Road, the right-of-way is 27.0 metres.
- Avenue Road is an important retail street and because

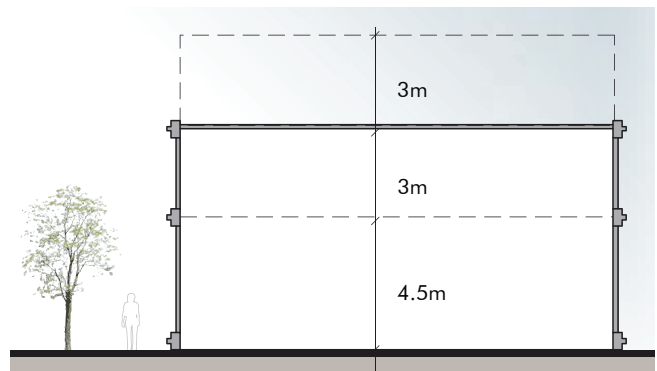

Buildings will not be less than 2-storeys, and 3-storey buildings will not require a 2nd storey stepback.

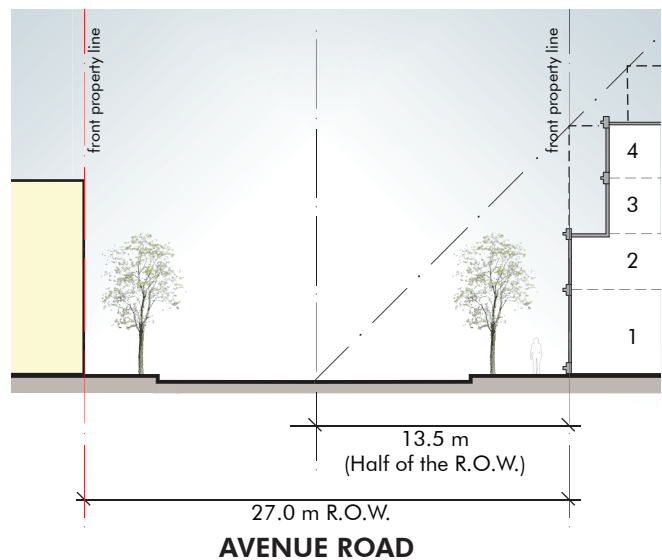

The Avenue Road R.O.W. is 27.0m wide. 27.0 m translates to approximately 4 storeys in height.

previous ACA guidelines took the visual angular plane from the centre-point of the road, this study applied the same principle. Half the right-of-way is approximately 13.5 metres which translates to 4-storeys. On lots up to a maximum of 37.0 metres, a stepped-back fifth storey could reasonably be developed within the visual angular plane. When applying the visual angular plane to the base condition the resulting height is typically 5-storeys or 16.5 metres.

- A 45° angular plane applied from the rear property line will ensure privacy between the stable residential neighbourhoods to the east and west of the Avenue Road fronting properties.

The following principles were developed for the base condition:

- A 5-storey (16.5m) height limit for the length of the Avenue Road Study Area;
- A stepback should occur at the top of the second storey facing the street to reference the established and historic 2-storey fabric of the street. An exception will be made for 3-storey buildings which will not require a stepback at the street wall;

- Mechanical penthouses or other rooftop structures cannot exceed this 5-storey height limit by more than 2.0 metres or penetrate the visual angular plane
- Building Setbacks at the rear should be a minimum of 7.5 metres where no laneway exists;
- Setbacks at the rear should be a minimum of 9.0 metres where a laneway exists. This rear yard setback is based on the standard of 7.2 metres for two-way lanes.
- Where a laneway exists in the rear yard, a sustainable landscape strip along the rear-yard property line must be provided (minimum width of 1.8 metres within the 9.0 metre setback). The design of this landscape strip must prove to be sustainable for irrigation, root and canopy growth, soil mass and type.

The application of these principles allows for buildings that provide very good sunlight access throughout the day by minimizing shadowing, maximizes sky-views and provides appropriate pedestrian scale.

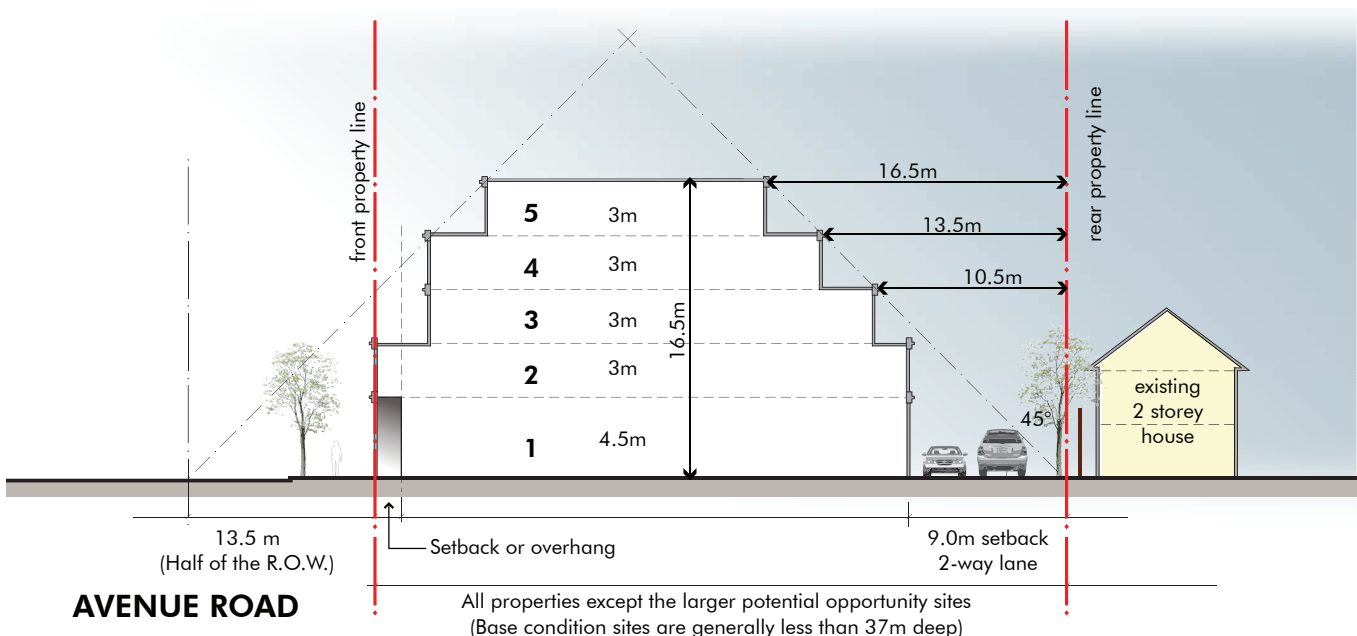

Height and massing principles for the base condition (average lot depths of 27.0 - 37.0 metres).

3 recommendations

The massing scenarios were modelled to demonstrate the impacts of height and how setbacks and stepbacks could be used to improve sunlight access by mitigating shadows on the street. Avenue Road is an important and vibrant retail shopping street and it is imperative that good access to sunlight be provided throughout the day. By applying the 45° visual angular plane from the centre-line of the right-of-way, sunlight on the opposite sidewalk is ensured until just after 3:00 in the afternoon on March 21st, the spring equinox.

The images below illustrate the sun and shadow analysis prepared for this study.

Base Condition on Sample Site (30m x 40m) on March 21st: west side of Avenue Road

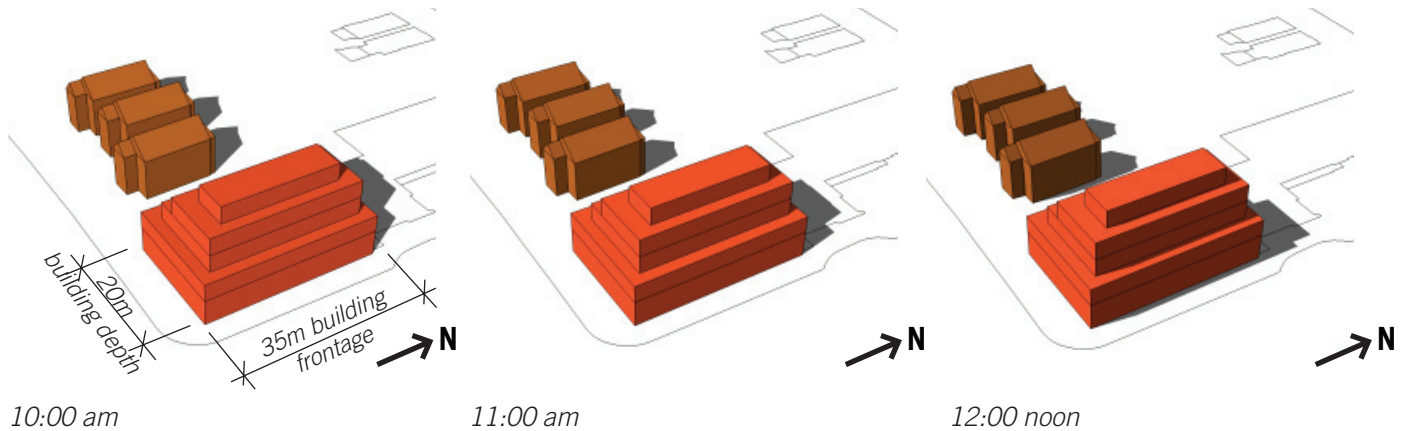

Base Condition on Sample Site (30m x 40m) on March 21st: east side of Avenue Road

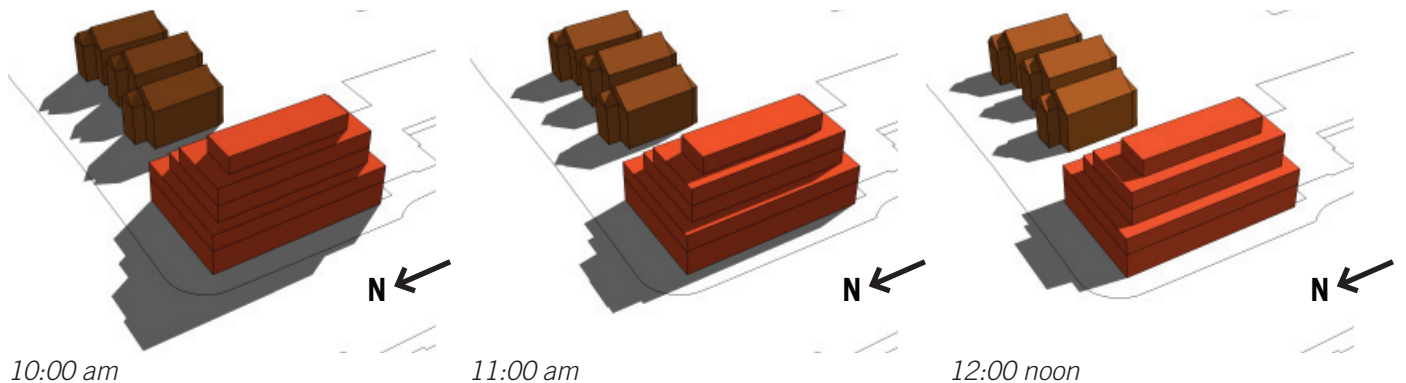

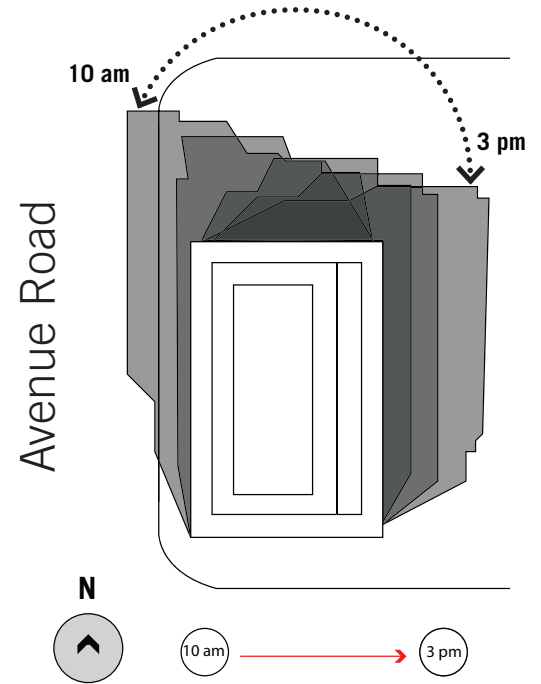
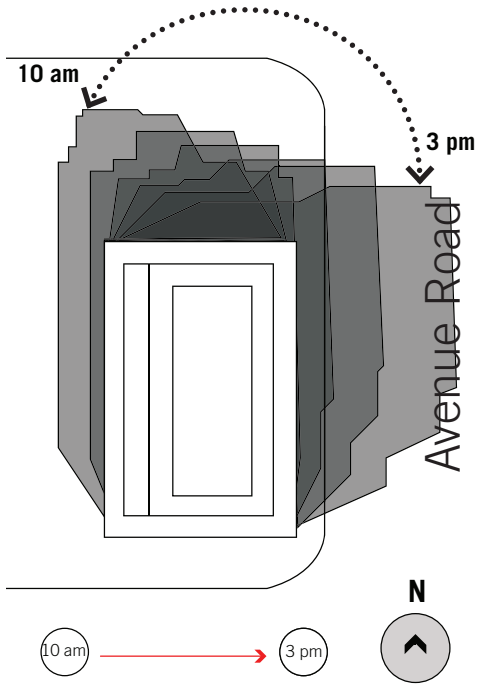

Property on the west side of Avenue Road

Property on the west side of Avenue Road

Shadow impacts of a five-storey building (with stepped-back fifth storey) on the east and west side of Avenue Road from 10:00 am to 3:00 pm.

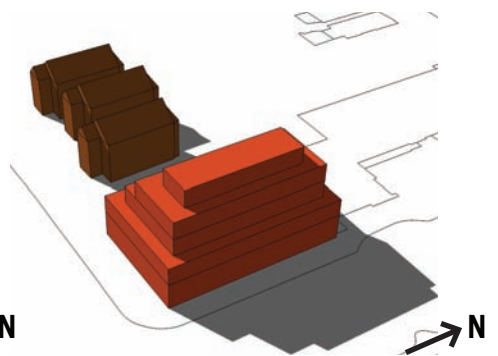
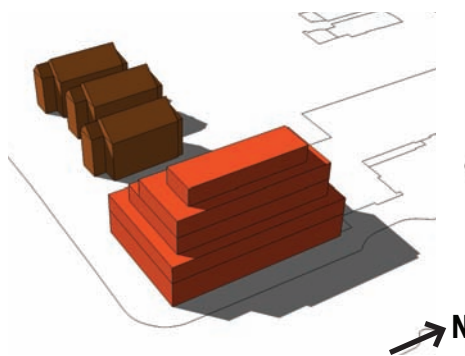
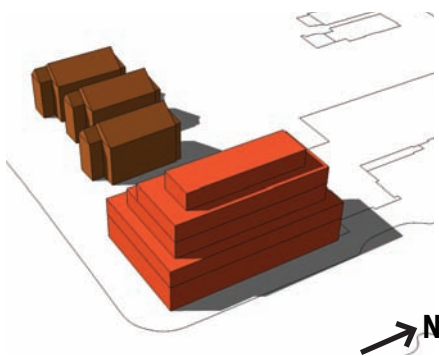

1:00 pm

2:00 pm

3:00 pm

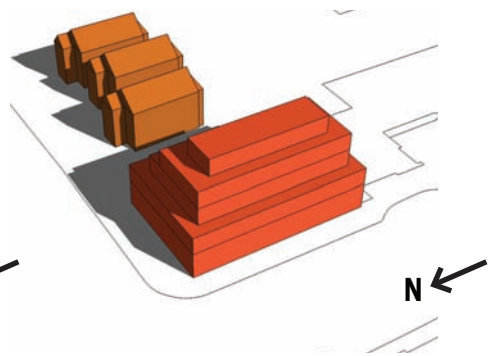
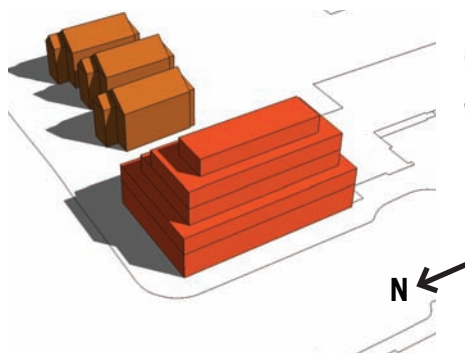
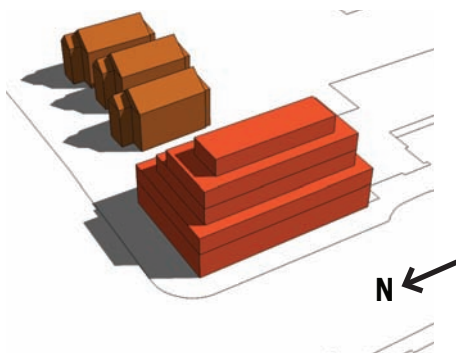

1:00 pm

2:00 pm

3:00 pm

3 recommendations

3.6.2 Height & Massing Principles for Larger Opportunity Sites

Within this approximate eighteen block length of Avenue Road from Wilson Avenue in the north to Lawrence Avenue in the south, nine larger sites have been identified as having potential for re-development. The majority of the redeveloped sites would also contain ground floor related retail uses, but would likely entirely replace the existing retail use.

When the nine identified larger opportunity sites are governed by the same principles that the base condition is, a maximum height of up to 7-storeys results. This 7-storey height limit is conditional on a minimum lot depth of 37.0 metres.

It is recommended that the building envelopes for these larger properties be included in the City Zoning By-Law and that this permission not be extended to any other sites on Avenue Road.

Below-grade parking would be necessary to support the height and density for both the 5-storey base condition and the larger sites. In previous studies, it was determined that a minimum lot depth of 38.0 metres is required for a

below-grade parking structure with a serviceable lane to the rear. Each of these nine sites have this minimum depth and the provision of below-grade parking is assumed.

In addition to principles a) through f) identified in Section 3.6.1, the following additional principles are proposed:

- g) Height will be limited to 7-storeys or 22.5 metres; and
- h) These envelopes will be included in the new zoning.

It is important to note that the height of the larger opportunity sites, was a point of contention with the LAC. There was no consensus on this discussion topic, as some felt that the base condition of a 5-storey maximum should be applied throughout the study area.

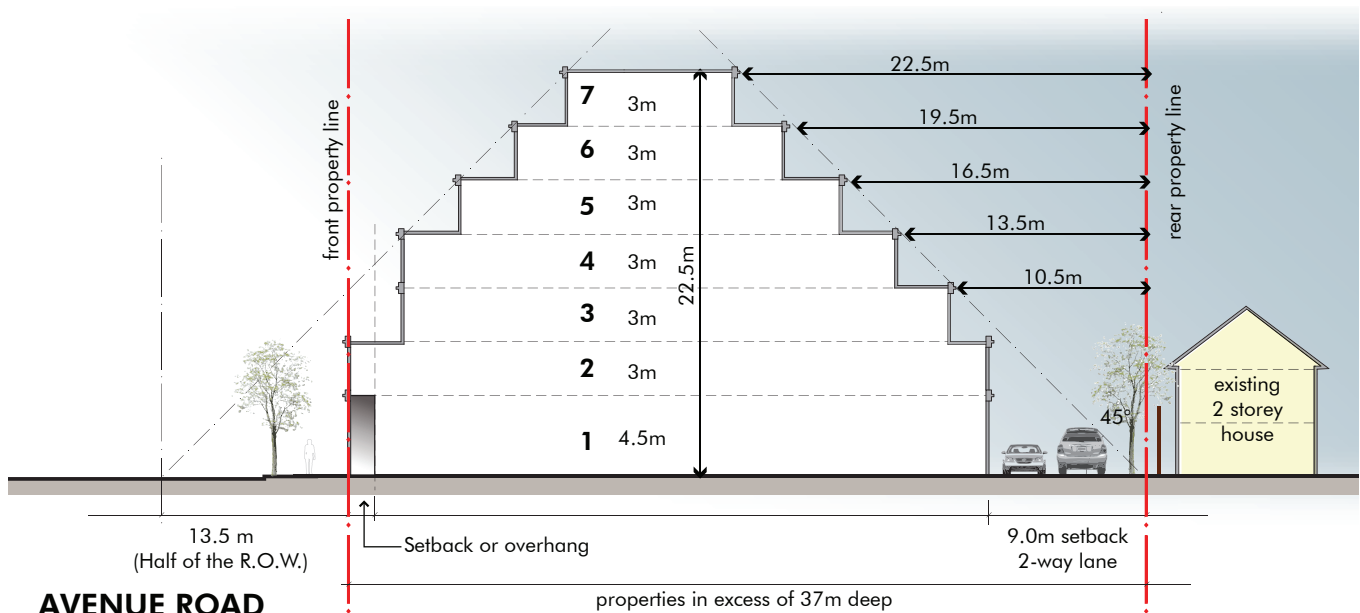

Height and massing principles for the nine larger opportunity sites.

The Nine Larger Opportunity Sites within the Overall Study Area

Existing Uses for the nine sites:

- Site 1: The Beer Store
- Site 2: KFC & Ex-Toggerly
- Site 3: Northwest corner of Brookdale Avenue & Avenue Road
- Site 4: McDonald's
- Site 5: Bruno's & Shopper's Drug Mart
- Site 6: No Frills & other several other retailer units
- Site 7: TD Bank
- Site 8: Nissan Dealership
- Site 9: Shopper's Drug Mart & RBC

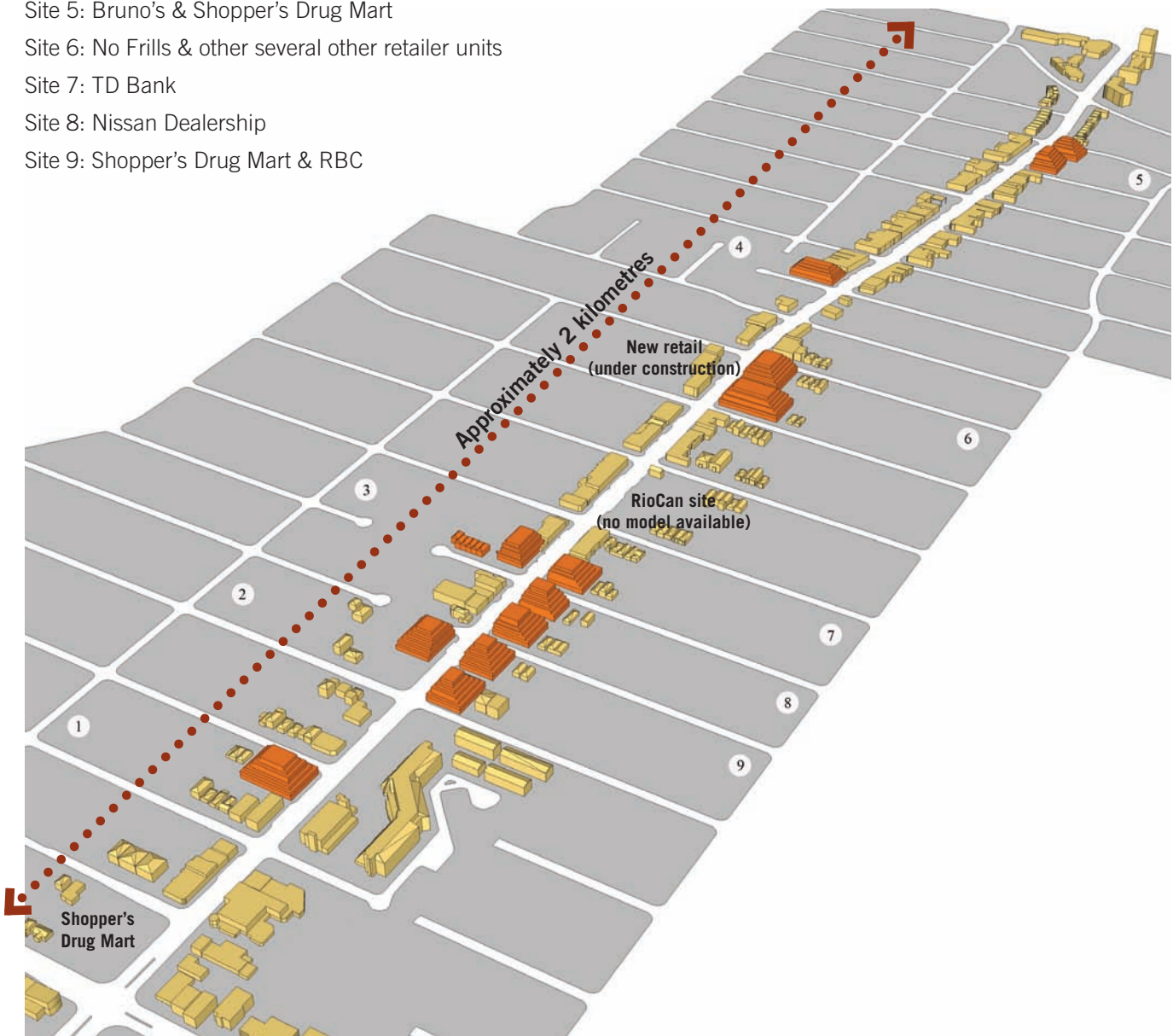

Larger opportunity sites (in orange) along Avenue Road.

3 recommendations

Site 1: The Beer Store

Location: between Douglas Avenue and Bedford Avenue on the west side of Avenue Road

Avenue Road frontage: 37m

Depth from Avenue Road property line: 58m

FSI calculated based on setback and stepback principles is: 3.44

Total units = 45



The Beer Store is located on the west side of Avenue Road.

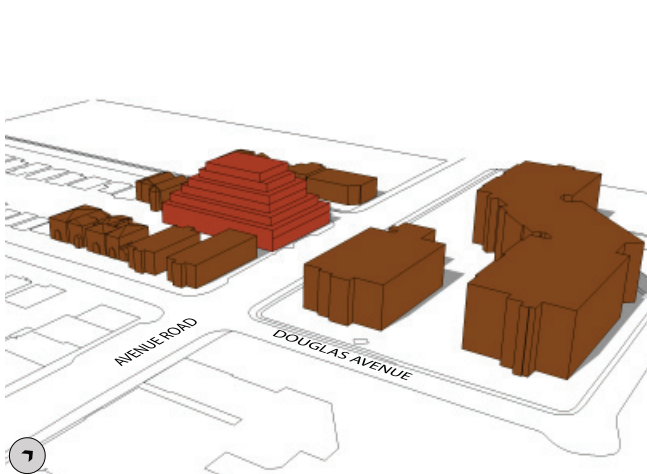

March 21st, 12:00 pm shadow looking north.

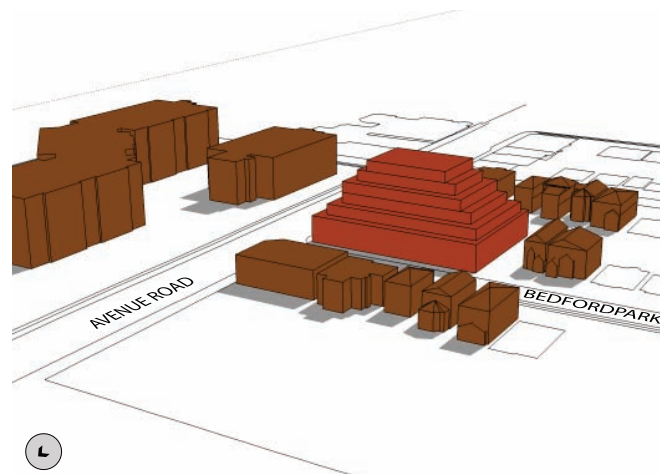

March 21st, 12:00 pm shadow looking south.

Site 2: KFC / Ex-Toggery

Location: between Woburn Avenue and Cranbrooke Avenue on the west side of Avenue Road

Avenue Road frontage: 29m

Depth from Avenue Road property line: 41m (varies)

FSI calculated based on setback and stepback principles is: 4.13

Total units = 43

Other information: Requires multiple consolidations.



The KFC restaurant is located on the west side of Avenue Road.

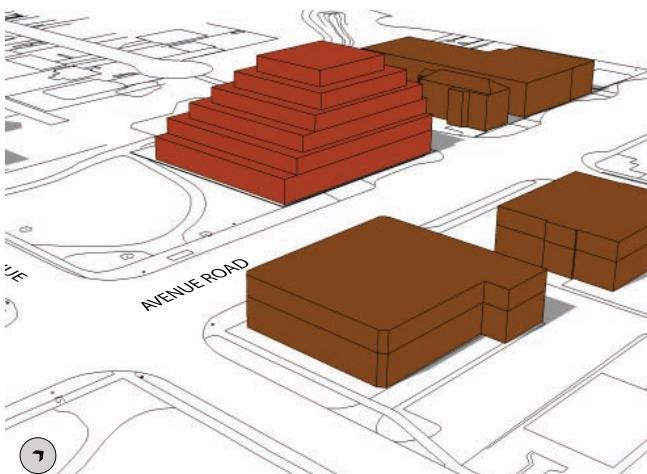

March 21st, 12:00 pm shadow looking north.

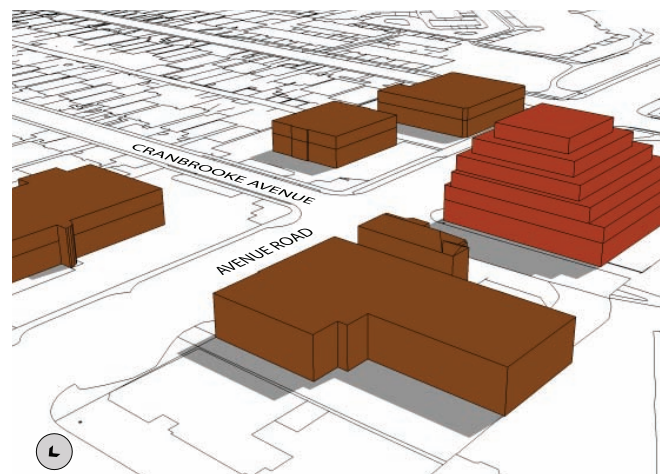

March 21st, 12:00 pm shadow looking south.

3 recommendations

Site 3: Brookdale Avenue

Location: The northwest corner of Brookdale Avenue and Avenue Road on the west side of Avenue Road

Avenue Road frontage: 47m

Depth from Avenue Road property line: 92m (varies)

FSI calculated based on setback and stepback principles is: 1.41

Total units = 39

Other information: Requires multiple consolidations and rental housing requirement applies.



Brookdale Avenue is a dead end street located on the west side of Avenue Road.

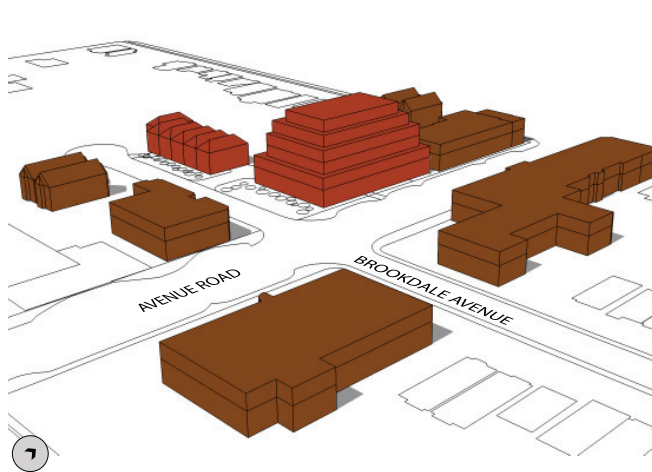

March 21st, 12:00 pm shadow looking north.

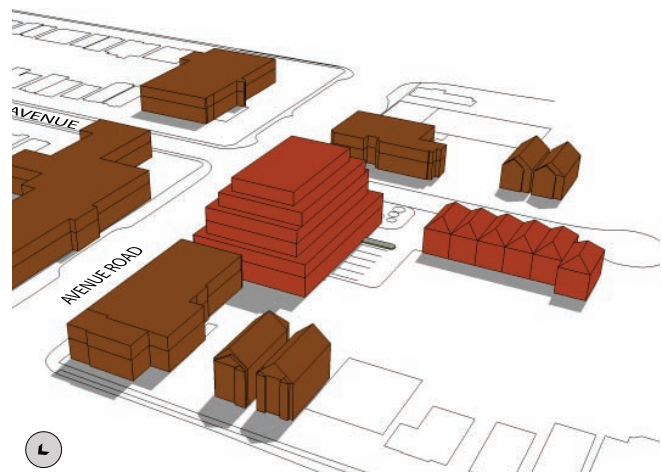

March 21st, 12:00 pm shadow looking south.

Site 4: McDonald's

Location: The northwest corner of Roe Avenue and Avenue Road on the west side of Avenue Road

Avenue Road frontage: 30m

Depth from Avenue Road property line: 66m (varies)

FSI calculated based on setback and stepback principles is: 2.95

Total units = 37

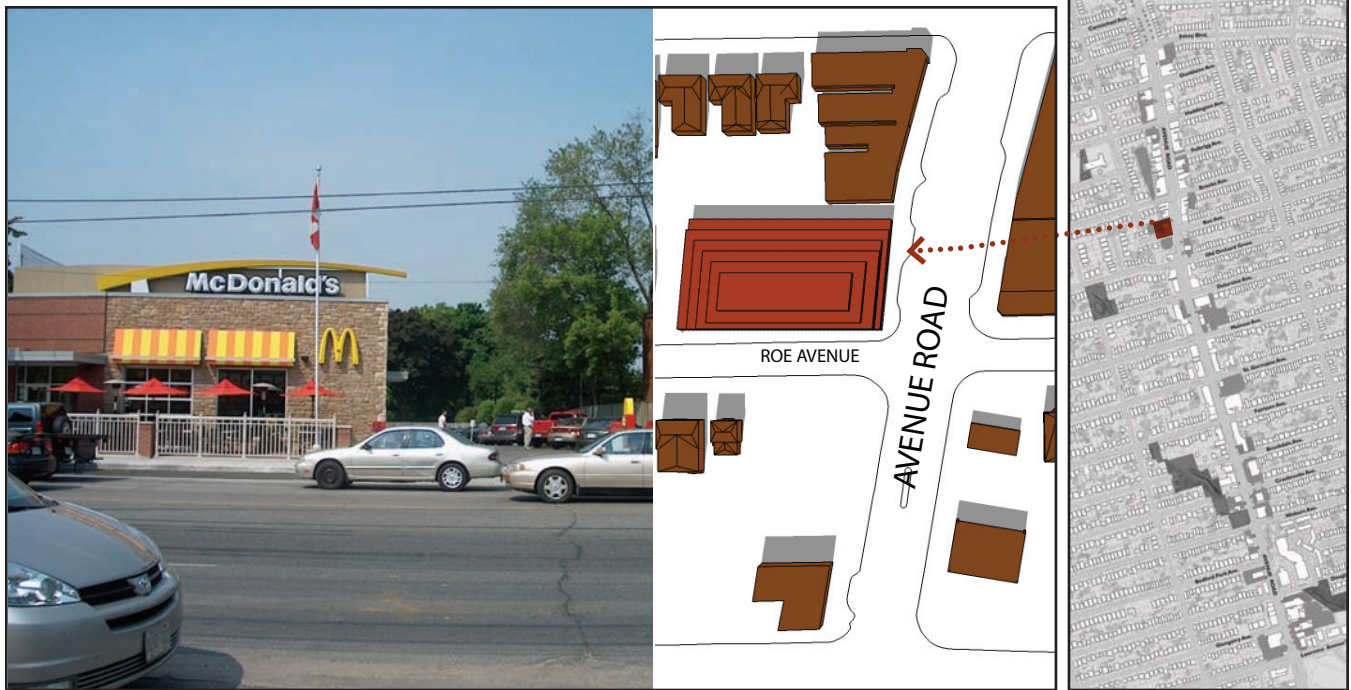

McDonald's restaurant is located on the west side of Avenue Road.

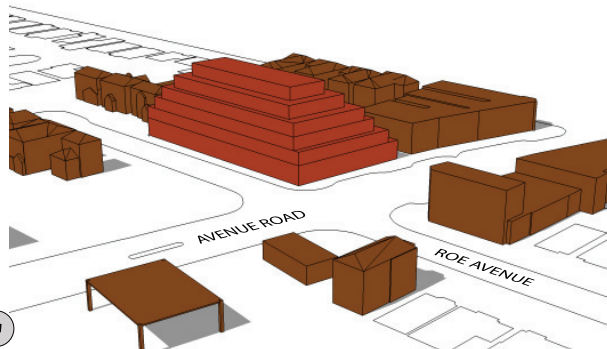

March 21st, 12:00 pm shadow looking north.

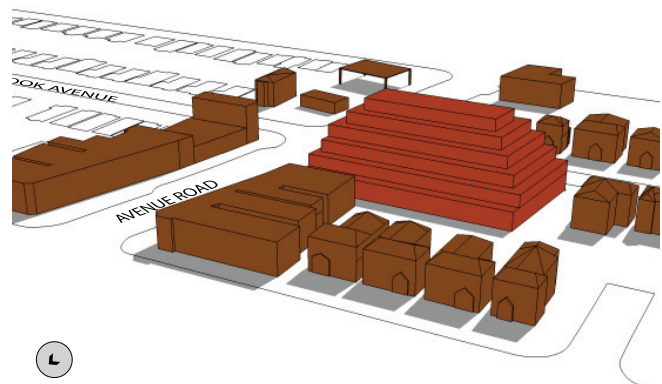

March 21st, 12:00 pm shadow looking south.

3 recommendations

Site 5: Bruno's and Drug Store

Location: between Dunblaine Avenue and Joicey Boulevard on the east side of Avenue Road

Avenue Road frontage: 76m

Depth from Avenue Road property line: 40m - 44m (varies)

FSI calculated based on setback and stepback principles is: 2.37

Total units = 55

Other information: Requires consolidation.

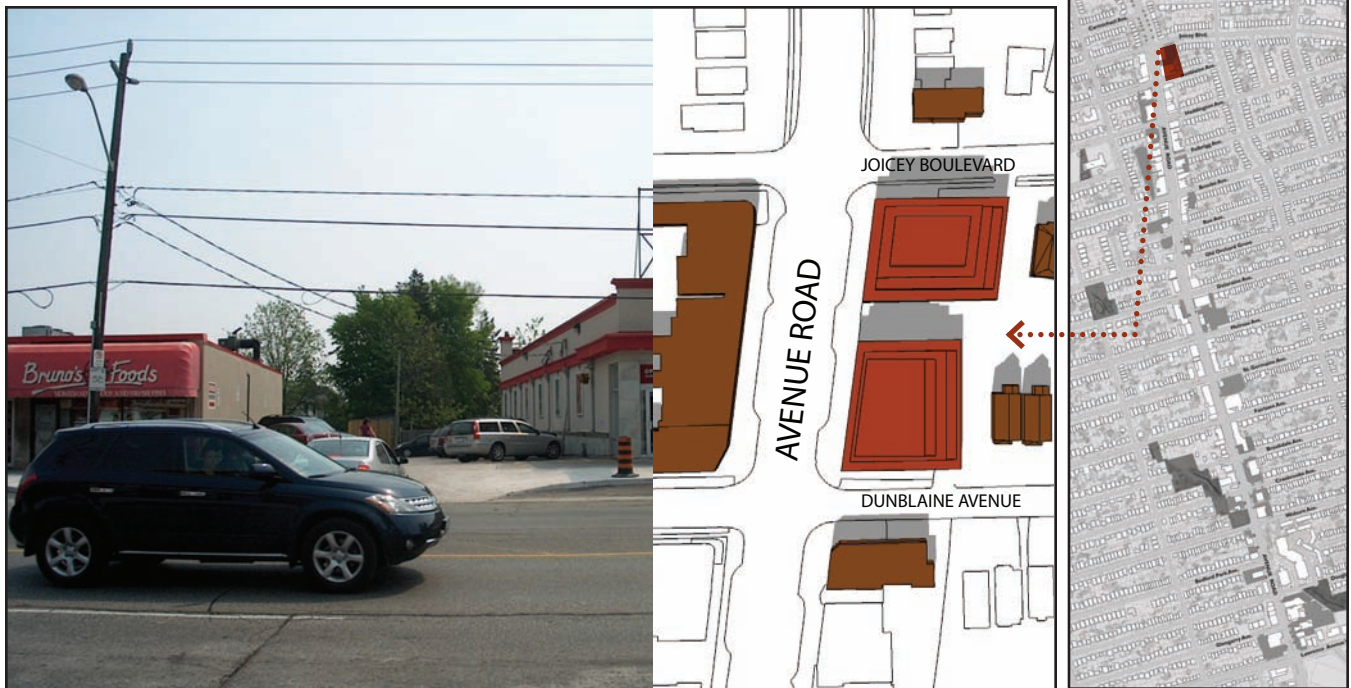

Bruno's grocery store is located on the east side of Avenue Road.

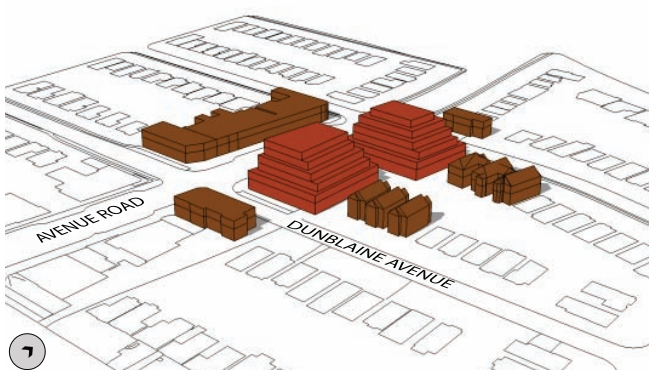

March 21st, 12:00 pm shadow looking north.

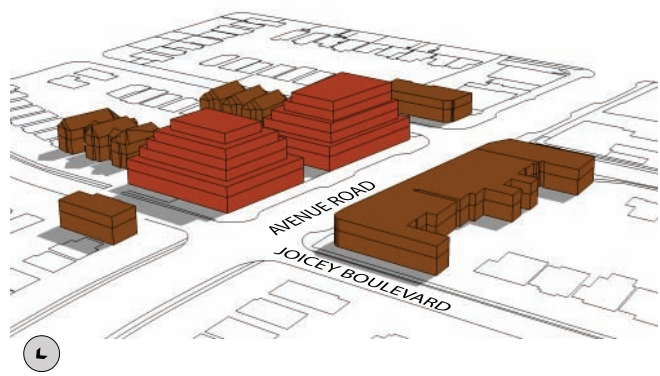

March 21st, 12:00 pm shadow looking south.

Site 6: No Frills and Adjacent Retail

Location: between St. Germain Avenue and Melrose Avenue on the east side of Avenue Road

Avenue Road frontage: 101m

Depth from Avenue Road property line: 51m - 73m (varies)

FSI calculated based on setback and stepback principles is: 3.57

Total units = 146

Other information: Requires multiple consolidations.



No Frills grocery store is located on the east side of Avenue Road.

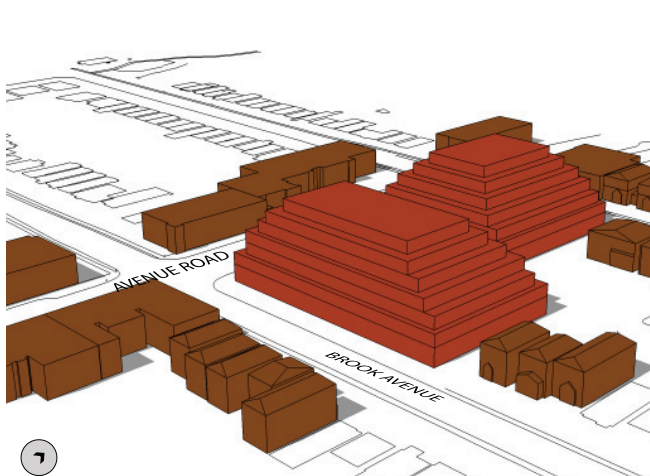

March 21st, 12:00 pm shadow looking north.

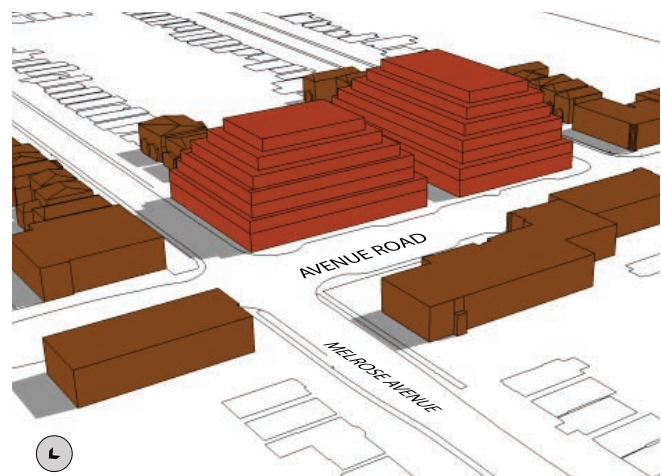

March 21st, 12:00 pm shadow looking south.

3 recommendations

Site 7: TD Bank

Location: The northeast corner of Brookdale Avenue and Avenue Road on the east side of Avenue Road

Avenue Road frontage: 34m

Depth from Avenue Road property line: 44m

FSI calculated based on setback and stepback principles is: 2.82

Total units = 30

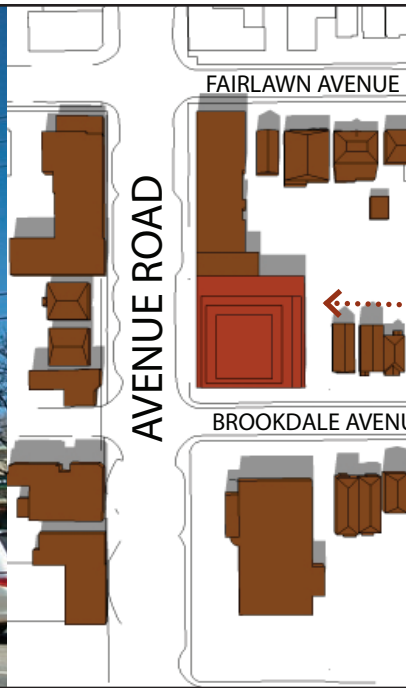

TD Bank is located on the east side of Avenue Road.

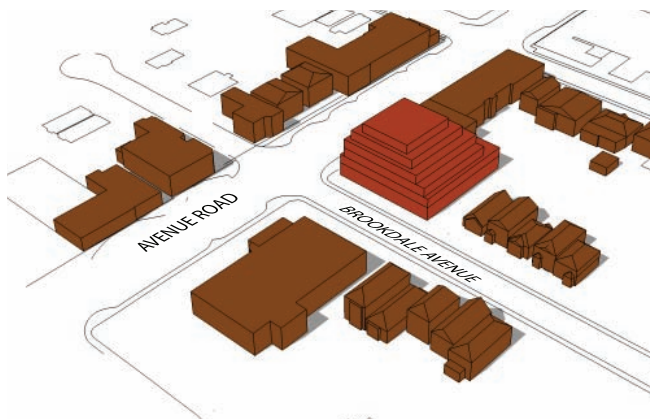

March 21st, 12:00 pm shadow looking north.



March 21st, 12:00 pm shadow looking south.

Site 8: Nissan Dealership

Location: between Cranbrooke Avenue and Brookdale Avenue on the east side of Avenue Road

Avenue Road frontage: 67m

Depth from Avenue Road property line: 44m

FSI calculated based on setback and stepback principles is: 3.13

Total units = 60

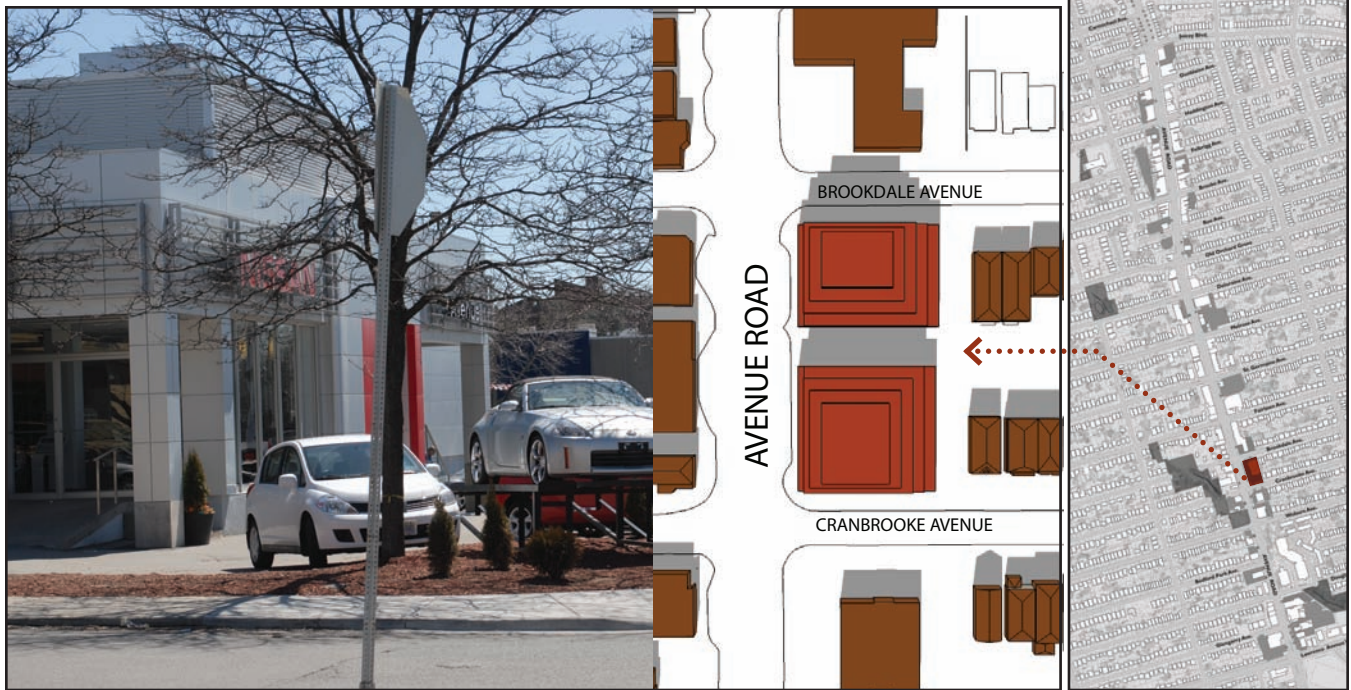

The Nissan Dealership is located on the east side of Avenue Road.

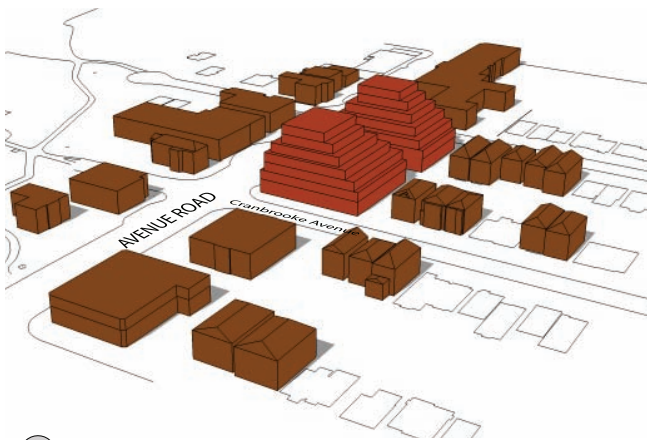

March 21st, 12:00 pm shadow looking north.

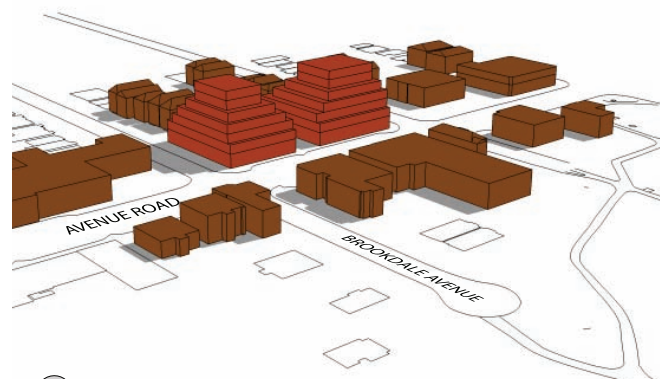

March 21st, 12:00 pm shadow looking south.

3 recommendations

Site 9: Shoppers Drug Mart and RBC

Location: between Woburn Avenue and Cranbrooke Avenue on the east side of Avenue Road

Avenue Road frontage: 33m and 37m

Depth from Avenue Road property line: 44m - 40m (varies)

FSI calculated based on setback and stepback principles is: 3.75

Total units = 78

Other information: Requires consolidation and purchase of City-owned laneway.



RBC Bank is located on the east side of Avenue Road.



March 21st, 12:00 pm shadow looking north.

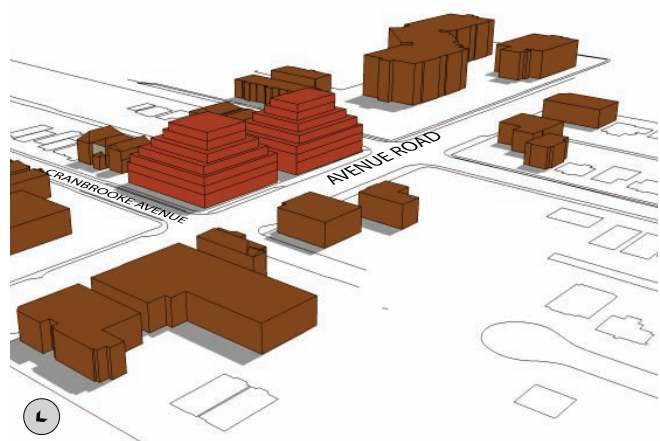

March 21st, 12:00 pm shadow looking south.

3.6.3 FSI & Density

This Avenue Study process was approached from a built form perspective, with the goal to determine what the buildings should look like in the Avenue Road context, based on integration with the existing main street retail and creating an appropriate transition to adjacent low-rise residential neighbourhoods. The objective was to develop a framework that controls the look and character of buildings along Avenue Road. From this position, a set of recommendations for height limits, stepbacks and setbacks were developed. A series of built form models were developed to illustrate the principles and criteria.

From the models, the resulting FSIs were in the range 2.26 to 2.90 x density for the base condition of 5-storeys and 1.41 to 4.13 x density for the nine larger opportunity sites. See tables below for details.

While these resulting densities exceed the existing 1x density permitted in the zoning for Avenue Road, 3x density is consistent with existing zoning for Avenues and other main streets within the city. Therefore, it is recommended that the permitted density be increased to 3x for the entire Avenue Road study area.

FSI from models for Base Condition

Sample Blocks (frontage x depth) (m)	Site Area (sm)	Building (with setbacks & stepbacks)		Building Area (sm) 1st floor only	FSI building sm/site sm	Residential Building Area building sm - 15% - 1st flr	Residential FSI res. building sm/site sm	# of units res. building sm/site sm
		Footprint (m)	Total Area (sm)					
Site 1 - 25m x 25m	625	25 x 16	1,411	400	2.26	799	1.28	8
Site 2 - 25m x 30m	750	25 x 21	1,976	525	2.63	1,155	1.54	12
Site 3 - 25m x 35m	875	25 x 26	2,541	650	2.90	1,510	1.73	15

FSI from models for Nine Larger Opportunity Sites

Block	Site Dimensions (m)		Site Area (sm)	Building Area (sm) (w/ setbacks & stepbacks)			Building Area (sm) 1st floor only	FSI building sm/site sm	Residential Building Area building sm - 15% - 1st floor	Residential FSI res. building sm/site sm	# of units A + B buildings
	frontage	depth		Building A	Building B	Total					
Site 1 - The Beer Store	36.6	57.9	2,120	7,300	—	7,300	1,700	3.44	4,505	2.13	45
Site 2 - KFC/Ex-Togery	38.6	41.1 (varies)	1,600	6,600	—	6,600	1,300	4.13	4,310	2.69	43
Site 3 - NW Corner Brookdale	46.5	91.5 (varies)	4,100	4,500	1,300	5,800	1,000	1.41	3,930	0.96	39
Site 4 - McDonald's	30.2	66.3 (varies)	2,070	6,100	—	6,100	1,500	2.95	3,685	1.78	37
Site 5 - Bruno's / Drug Store	76.2	44.6/39.9	3,750	4,600	4,300	8,900	2,100	2.37	5,465	1.46	55
Site 6 - No Frills/Ely's/Harvey's	101.4	51.0/72.8 (varies)	6,300	12,500	10,000	22,500	4,500	3.57	14,625	2.32	146
Site 7 - TD Bank	34.3	43.9	1,700	4,800	—	4,800	1,100	2.82	2,980	1.75	30
Site 8 - Nissan Dealership	67.1	43.9	3,000	5,200	4,200	9,400	2,000	3.13	5,990	2.00	60
Site 9 - RBC/Shopper's	33.4 36.6	44.2 39.5	3,250	6,300	5,900	12,200	2,600	3.75	7,770	2.39	78

533

Assumptions used for tables

- * Unit size of 100 square metres (1,000 square feet).
- ** 15% deduction from building area to determine occupiable residential space.
- *** First floor of all buildings (except townhomes) are non-residential.

All information related to property frontage, depth and total site area is based on available information at the time of analysis.

3 recommendations

3.6.4 Front Property Building Setbacks

For much of the length of this section of Avenue Road, the sidewalks are quite wide. From property data information, the sidewalk widths range from 2.0 metres to almost 5.0 metres. North of Melrose Avenue, a building setback from the front property line has been maintained so that the wide sidewalk is maintained. All new developments should maintain this setback.

The space captured by this front setback will provide additional open and green space and can be used for outdoor display, cafes, and landscaping. Pedestrian weather-protection should also be encouraged through the use of awnings and canopies.

This setback from the front property line should continue to be applied, where it does not limit the viability of development or redevelopment of a property. The sidewalk and front façade of Avenue Road fronting properties should generally be continuous, except where building forecourts, gardens or other public access is required.

South of Melrose Avenue, the application of a front setback should be implemented on a site-by-site basis through the City's urban design guidelines.



Existing building setback City right-of-way



City right-of-way



City right-of-way Additional building setback or overhang

3.6.5 Impacts From Developments

While the recommended heights outlined in the previous sections exceed the form of development that is currently permitted on Avenue Road, potential impacts from the build-out of these sites is considered to be minimal. In considering the increase in height on the nine larger opportunity sites, the following questions were raised:

1. Would a recessed 6th and 7th storey significantly impact shadows and/or skyview?
 - Stepbacks and angular plane will maintain sunlight (on September/March 21st until 3:00 pm - 4:00 pm) on one sidewalk.
2. Would units in a 6th and 7th storey create significant additional traffic loads on Avenue Road and the surrounding residential streets?
 - Physical dispersion of the 9 sites along the length of Avenue Road (from approximately 540 units, at 2 people/unit = 1080) will not result in a significant traffic impact.
 - Vehicular traffic to and from Retail/Commercial uses could be reduced by the change of land use. Retail at-grade in new developments will likely be community-oriented and smaller scale; combined with other local retail, walking can be a relied upon method for shopping.
3. Would a recessed 6th and 7th storey result in buildings out of proportion with the street width and other buildings, and result in an overwhelming sense of enclosure for pedestrians?
 - Stepbacks and setbacks from the neighbourhood will provide a transition in scale and maximize privacy. Wide right-of-way width (27m) is balanced with buildings of 7-storeys (22.5m).
4. Would units in a recessed 6th and 7th storey result in requirements for additional City community services and facilities (schools, community centres, etc.)?
 - Existing Parks deficiency to be addressed through study recommendations.
 - 1080 additional residents through potential new development over time.
 - Community services and facilities are available in proximity.
5. There is capacity for enrolment at five of the seven elementary schools and only one of the three secondary schools (as per School Board info). The increased demand generated from the estimated 540 additional units contemplated as part of the Avenue Study will result in approximately 50 students. The local boards of education have indicated that they will accommodate this increase through changes to programs, attendance boundaries and the possible placement of portable classrooms.
5. Would 6 or 7 storey buildings be out-of-keeping with the urban design policies of the new Official Plan and zoning for other Avenues with similar right-of-way widths? Would 6 or 7 storey buildings be out-of-keeping with Provincial Policy Statements?
 - Mid-rise buildings (5 – 7 storeys) are consistent with permissions for Avenues with similar road widths elsewhere in the City. These buildings would also not conflict with Provincial Policy Statements.



Stepbacks and angular planes will help mitigate shadow impacts.

3 recommendations

Traffic and Transportation Impacts

The redevelopment of the nine larger opportunity sites from primarily vehicular-oriented retail to pedestrian-oriented uses will reduce the number of vehicle trips from that currently being generated by the existing uses. As an example, an estimated 533 new dwelling units would result from build-out of the nine larger opportunity sites. These 533 dwelling units would:

- Generate a total of 178 vehicle trips - 30 inbound and 148 outbound in the morning peak period; and
- Generate a total of 218 vehicle trips of which 146 would be inbound and 72 would be outbound in the afternoon/evening peak period.

Given there are nine sites, each site would average approximately 20 vehicle trips in the morning peak period and 24 vehicle trips in the afternoon/evening peak period.

The nine sites are dispersed over a relatively long distance. The vehicle trips generated by any one site would result in a negligible impact on Avenue Road or on any of the side streets.

The ground floor related retail will also be very different from the current land uses. Although some of the current uses such as a drug store or financial services could operate in new store frontages, it is more likely the new storefronts will provide services and amenities that are more related to the needs of the surrounding community. They will have a significantly less regional draw, with much fewer vehicle trips generated. In turn the grade related retail activities, when combined with other existing businesses provide area residents with an ability to complete multiple shopping trips through walking. This is due in-part to the nature and size of retail in mixed-use buildings which tend to have a smaller floor plate which leads to locally-oriented stores.

3.7 Other Recommendations

3.7.1 Ground-Floor Retail & Mix of Uses

In keeping with the existing and historic character of Avenue Road, a continuous and active retail frontage should be maintained at-grade. The east and west sides of Avenue Road should be treated similarly in order to create a cohesive urban environment which provides a pedestrian-orientation.

To ensure the public accessibility of uses along the Avenue Road frontage, residential or office uses should generally be discouraged at-grade on Avenue Road. Commercial uses that create interest for the general public or that may be visually open to the sidewalk, such as real estate offices or banks, may be allowed at-grade.

For larger developments, lobbies or other shared internal spaces will require access from the Avenue Road frontage. These spaces should maintain the regular rhythm of retail frontage.

Commercial office uses should be located in levels above grade. In order to create the vibrancy and critical mass of residential population on the street which leads to all-day use of the street, all buildings should have retail at-grade. Larger buildings may have a mix of retail, commercial and residential. However, office-only buildings (with retail at-grade) up to the maximum density will not be permitted.

Retail and commercial uses should be directly accessible from the public sidewalk ramped accesses should be avoided unless necessary.



“Active” frontages should be maintained at grade.



Office uses should be located above grade.



Newer developments on Avenue Road already provide for a mix of uses.

3 recommendations

3.7.2 Home Occupations

Currently, the Official Plan permits home occupations in residential neighbourhoods throughout the City. A home occupation occurs when a person opens an office or studio in a portion of their home and uses it as their primary place of work. Home occupations are not permitted in residential districts in the Zoning By-law that covers the former City of North York, By-law 7625. In the portion of the study area east of Avenue Road that is in the former City of Toronto, covered by Zoning By-law 438-86, home occupations are permitted in the low-rise residential neighbourhoods under certain conditions.

Home occupations are beneficial to as they:

- Provide flexibility to work from the home for individuals with family responsibilities;
- Are an incubator for new businesses that cannot yet afford to pay rent;
- Allow people to work without travel in peak hours thereby reducing traffic congestion and greenhouse gas emissions; and
- Keep more people on the block to watch over the neighbourhood during the day.

Initial concerns that residential neighbourhoods would become ‘commercialized’ or experience traffic problems have not materialized where home occupations have been permitted.

After reaching a consensus within the Local Advisory Committee, including representatives of the local Ratepayers Associations, this study recommends that Zoning By-law 7625 for the former City of North York be amended for the portion of Avenue Road north of Joicey Boulevard and the other low-rise residential neighbourhoods in the North York portion of the study area. The same home occupations should be permitted under the same conditions as are permitted in the portion of the study area in the former City of Toronto.

A home occupation, or ‘home-work use’, would be a permitted use accessory to a dwelling unit subject to the following conditions:

- The work use would be restricted to an office, studio, caterer, barber, hairdresser, beautician, dressmaker, seamstress or tailor;
- The total gross floor area used for the work area would not be greater than 30 square metres or 30 percent of the dwelling - whichever is less;
- There is no sale of goods from the dwelling;
- Music or dance studios would only be allowed in detached houses with one dwelling unit within, and the music instruction is not for electronically amplified instruments;
- Only one or two residents of the dwelling unit may work in it and no outside employees are permitted except for regulated health professions where up to 2 outside employees would be permitted;
- No part of an accessory building or garage is to be used for the work premise; and
- There is no outdoor storage permitted.

There are no sign provisions for home occupations in the former Toronto Zoning By-law. The North York sign by-law does permit small signs for professional and business offices as well as professional health offices. In order to maintain the residential nature of the low-rise neighbourhoods, this study recommends that only small signs for regulated health professionals be permitted where there are home occupations.

There was some discussion of whether the detached homes on Avenue Road north of Joicey Boulevard should be used for wholly commercial purposes. However, given the difficulty of access and egress on this congested portion of Avenue Road south of the 401 ramps, it is recommended that these dwellings be limited to live/work or wholly residential uses. On the few corner lots where there is a possibility of access from the side street and additional parking, the owners may seek to amend the by-law to permit wholly commercial uses on a site specific basis.

3.7.3 Side Street Commercial

There are a limited number of properties on side streets that are designated *Mixed Use Areas* and zoned C1. Some are simply detached dwellings, some appear to be operating as home-based business, while there are others, at Dunblaine Avenue for example, operating as retail businesses. To-date there has been no consolidation of these side street properties with those fronting Avenue Road with the exception of the Fairlawn Market (1704 Avenue Road). These properties are currently zoned for as commercial uses, and it is recommended these permissions remain.

The zoning for these sites should therefore remain C1 that permits up to 3 storeys and 1x density of residential, commercial and/or mixed use. An Official Plan Amendment (OPA) should limit the development of these properties to low-rise or house-form scale and character. Given that any development of these properties could remain residential in character, these properties would form a transition in height and scale from Avenue Road to the neighbouring residential areas.

These properties could still be consolidated with Avenue Road fronting properties but should only be used for low-scale house-form commercial or residential uses and perhaps ingress/egress or open space.



Fairlawn Flower Market is a corner lot commercial property that has consolidated with the side street properties zoned C 1.

3 recommendations

3.7.4 Traffic & Vehicular Access

Based on an analysis of traffic counts generated over the course of several years, the total number of vehicles using Avenue Road has not increased significantly. The community cites traffic congestion as a worsening problem, and it is suggested that the increase in local traffic infiltration is occurring from short-cuts through the neighbourhoods to avoid Avenue Road. The traffic impact generated from build out of all of the nine larger sites is expected to have no adverse impact on Avenue Road traffic (see Section 3.6.5.).

The problem of traffic infiltration through the neighbourhoods is recognized and although the scope of this study does not allow for an area-wide traffic study, it is recommended that in the short term, the City conduct an area traffic study to identify problems and measures to discourage cut-through traffic and improve pedestrian safety on local streets east of Avenue Road.

Vehicle access to redeveloped sites on Avenue Road should be provided on the side streets. This is recommended for a number of reasons:

- Access driveways break up the street façade;
- Access driveways result in more curb depressions that pedestrians need to cross, also increasing the potential for conflicts between pedestrians and vehicles;
- More vehicular conflicts are created particularly as drivers try to make left turns out of driveways onto Avenue Road;
- A good number of the side street intersections on Avenue Road are signalized. These allow for left turns to be made safely onto Avenue Road; and
- Opposing driveways which are off-set result in interlocking left turns.

Physical design measures and signage should be used to divert traffic from new developments on Avenue Road away from the neighbourhood. These design measures should be determined on a site by site basis.

3.7.5 Parking

While Avenue Road is generally well-served for short and long-term parking with the on-street parking and bump-out system, the southern portion of the study area is lacking in short-term parking. The Toronto Parking Authority has been approached about this, and it is recommended that Council make a formal request for this.

The Toronto Parking Authority (TPA) had indicated their willingness to pursue additional parking in the south half of the Avenue segment, likely going underground in a future development.

The form of a new lot would be provided by the TPA either purchasing land and building a lot, or purchasing floors of parking within a new development.



Additional parking is required in the southern portion of the study area.

3.8 Community Association

There is currently no Business Improvement Association or even a Business Association in this section of Avenue Road. From previous experience and the responses to the retail survey that was conducted through the course of this project, it is unlikely that one will be formed. There are four ratepayers associations in the surrounding area, South Armour Heights Residents Association, North Avenue Road Residents Association, Bedford Park Ratepayers Association and the Old Orchard Residents Association. The Associations are deeply involved in community issues and the Avenue Road corridor and will continue to be so. There is however, interest in a “Community Association” from both residents and some business representatives. The Councillor’s office has committed to assisting interested community representatives in this endeavour. A number of LAC members have also expressed interest in participating.

Likelihood of implementation of many of the recommendations in this report would be greatly enhanced if a Community Association were to be formed. Other initiatives that could be taken on by the Community Association include:

- Design and maintenance of the green fingers;
- Solicitation of funding or donation to contribute to public art or gateways;
- Formation of a professional, local, design review committee to work with the City on reviewing development applications;
- Branding initiatives to promote the “Upper Avenue”; and
- Coordinated street furniture site plan review.



Public art along Avenue Road should be of an appropriate scale. Functional pieces, such as the bench at right, maximize the use of the sidewalk.

3.9 Section 37

Section 37 of the *Planning Act* allows municipalities to permit additional heights and densities above what the Zoning By-law would normally permit in return for ‘community benefits’ such as affordable housing, community facilities, public art or contributions to parks above and beyond the normal parks levy. The City requires that the development represent good planning that meets the policies of the Official Plan before there is any consideration of a Section 37 agreement. It is not simply the buying of additional height or density in exchange for community benefits.

The LAC discussed the role of Section 37 on Avenue Road and whether the Avenue Study should identify the priority community benefits should a Section 37 agreement be proposed. One of the primary purposes of the Avenue Road Avenue Study is to replace the outdated C1 zoning and create new zoning regulations that are reasonable for residents and property-owners alike and defensible if appealed to the Ontario Municipal Board. The regulatory scheme set out in this study provides maximum heights and densities and building envelopes that are based on solid planning principles and can be defended by City staff at the Ontario Municipal Board if challenged. The Local Advisory Committee, consultants and City Planning staff are recommending that new development implement the framework for growth that has been established through this Avenue Study, and that the City approve only development that generally meets the development framework.

As new development should meet the Zoning By-law provisions established by this Avenue Study, there would be no requirement for Section 37 agreements. This study therefore does not specifically identify priority community benefits for Section 37 agreements in this segment of Avenue Road.



4 design guidelines

4.1 Built Form

Built form guidelines can be used to guide the design and evaluation of development proposals. Response from the public with regards to built form was extensive. Building height was a contentious issue, but many did recognize that the impact of building height and mass can be mitigated by stepping building massing away from streets adjacent homes and architectural design that is sensitive to its surroundings.

4.1.1 Building Orientation and Layout

The orientation of buildings and overall site layout are key considerations that when designed correctly will enhance the existing character of the street. This is achieved by relating buildings to the street and to pedestrian activities, integrating landscaping and green spaces, and a range of setbacks. The existing continuous street façade is an important characteristic of Avenue Road's retail-orientation and should be maintained and enhanced in new developments.

Locations where the street façade is not proposed to be continuous through differing setbacks must be carefully considered to provide special treatments such as urban or civic plazas or parkettes. These locations must consist of publicly accessible open spaces with high quality urban design and landscaping. All new buildings should adhere to the following guidelines.

- All new buildings and developments shall be located along the street-facing context to frame the abutting streets and create a continuous street edge harmonious with its neighbours. Building walls shall also frame and define internal drive aisles, pedestrian walkways, parking areas and amenity spaces.
- Parking areas should never be located between the sidewalk and the building façade.
- Setback at the rear should be a minimum of 7.5 metres where no laneway is proposed and a minimum of 9.0 metres where a laneway is proposed.
- Setbacks should be consistent with the existing framework of setbacks where a wider sidewalk is provided. Please refer to Section 3.6.3 for specific recommendations.
- New buildings and developments shall occupy at least 80% of the property line along Avenue Road.
- Where the length of property frontage permits, publicly-accessible mid-block connections should be incorporated into new developments to enhance pedestrian circulation and the permeability of sites.
- All new buildings and developments shall have a maximum setback distance of 2.5 metres for façade recesses to allow for variety in façades and building placement, as well as locations for formal civic spaces, display, cafes or seating areas.



Buildings should be built to the front property line, except where accommodations are made for plazas or green space.



Buildings should step-down to transition towards the adjacent low-rise residential neighbourhoods.

4.1.2 Building Heights & Massing

A context sensitive approach to height and massing should respect existing built form and aid in the creation of a vibrant streetscape. Please refer to Section 3.6.1 for specific recommendations for Building Height and Massing. Other recommended guidelines for reducing the impact of contextually larger buildings are as follows:

- All new buildings and developments must be a minimum of two storeys (7.5m) in building height.
- A 5-storey (16.5m) height limit will apply for the length of the Avenue Road Study Area. Only the nine opportunity sites, as identified in Section 3.6.2., will have an upper height limit of 7-storeys (22.5m).
- The character and location of adjacent building on the Avenue Road frontage will affect the setback and step-backs of side yards. This could necessitate a setback on the sides of buildings to allow for windows on all sides.
- Buildings that are in excess of 3-storeys will require a stepback at the top of the second storey. Buildings that are 3-storeys or fewer will not require a stepback at the Avenue Road frontage.
- All step-backs of the building wall shall be a minimum of 2.0 metres back from the building face of the storey directly below or as required by the Visual Angular Plane Analysis. Step-backs will minimize the appearance of the overall building mass and provide opportunities for usable outdoor spaces such as terraces and green roofs.
- Mechanical penthouses or other rooftop structures cannot exceed this 5-storey height limit by more than 2.0 metres or penetrate the visual angular plane.



Buildings that are three storeys in height or less should not require a stepback.

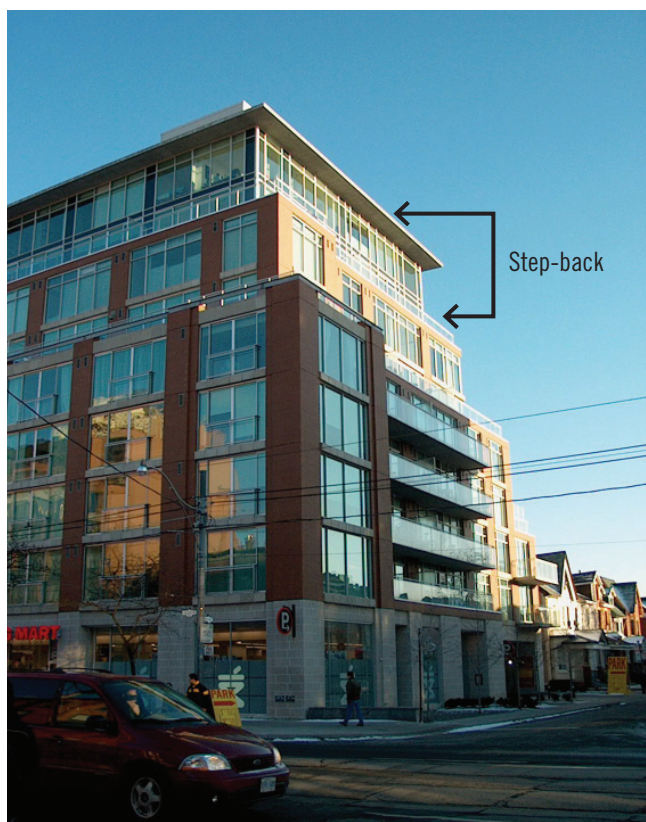

This development respects the scale of surrounding buildings and successfully uses step-backs to minimize the presence of its upper floors on existing residential buildings.

4 design guidelines



Variations in façade in the horizontal and vertical wall plane will replicate the main street character and scale.

4.1.3 Building Façade Articulation

A well designed building will add visual interest to a street and respond to the existing streetscape conditions through its architectural expression. This is particularly important for retail-oriented streets such as Avenue Road. The expression of public or active uses can be achieved through expansive glazing and multiple entrances to add visual interest and to improve functionality and legibility of retail uses.

- New buildings will ensure a continuous retail edge, with retail uses at grade, directly accessible from the public sidewalk.
- Buildings with frontages exceeding 12 metres should be strategically divided into functionally and visually smaller units through the use of façade articulation, internal courtyards, networks of connected walkways and landscaping.
- All building façades facing (or visible from) streets and public spaces shall provide façade variation in both the horizontal and vertical wall plane. No building façade should extend beyond 3.0 metres horizontally without appropriate façade variation. This articulation of the ground floor will integrate new developments into the existing streetscape that is predominantly individual storefronts with individual identities.
- Building façades and building walls should be varied in both the horizontal and vertical plane through the installation of a mix of functional building elements and architectural details (e.g. friezes, canopies, glazing details and/or overhangs), use of materials, openings in the façade, and projections and recessions.
- Storefronts and entrances should be designed to integrate with existing streetscape details and materials, ratio of glazing to solid wall, lighting, signage type and location, canopies, types of doors and width of retail units.
- Buildings should not have blank façades. Where buildings are prohibited from using windows, e.g. where future adjacent development is anticipated, the side façades should still incorporate a minimum level of articulation. This may include detailed brick work, ornaments or murals.

- All new buildings and developments that occupy a corner site should acknowledge the corner condition through architectural expression and should feature fully developed façades along both frontages including a minimum of one display window or entrance located at the corner of the building and on each façade within proximity of the corner.
- All building façades facing streets and public spaces should incorporate vestibules, frequent building entrances, covered walkways, canopies and awnings along the first storey to provide weather protection and to add visual interest to adjacent pedestrian areas.
- All new buildings and developments should integrate building elements such as vents or rainwater leaders within the wall plane or other façade features to mitigate any potential negative impacts on public and pedestrian areas.
- All new larger buildings and developments shall be designed with continuous street façades that incorporate appropriately-scaled and well-designed 'breaks' featuring opportunities for public open space, mid-block pedestrian walkways and/or private rear yard access.
- New buildings and developments should maximize opportunities to create new public pedestrian routes through the site to connect with the public sidewalk network and with other established pedestrian walkways. These connections will encourage pedestrian access from the adjacent residential areas.
- All new buildings located at important corners or at T-intersections, along walkways, facing parks or open spaces should clearly mark the corner through the use of vertical and architectural elements which emphasize the visual and functional prominence of the site. Elements can include towers, bays, accentuated rooflines, projections, recesses, canopies and/or other architectural detailing.



Corner buildings should address the corner conditions through architectural expressions.



Larger developments should incorporate public through-block connections for access and to break up long façades.

4 design guidelines



Building materials should be harmonious with existing context.

4.1.4 Building Materials & Details

The choice of building material is integral to the appearance of new buildings. The material selected should respond to the design and style of the proposed building. The use of high quality and durable building materials for new developments will promote the feeling of permanence and quality construction.

- All new buildings and developments should utilize building materials chosen for their functional and aesthetic qualities. All exterior building finishes should demonstrate a high quality of workmanship, durability and ease of maintenance.
- Building materials and finishes/accents on building façades facing onto or visible from streets and public spaces shall not include synthetic siding systems, mirrored/heavily tinted glass panels and unadorned concrete block.
- All new buildings and developments should have well-considered building materials at the ground floor that is of a pedestrian scale and responds to surrounding buildings.
- Detailing and signage should enhance the overall character of the area. Corporate signage should not dominate building façades. Signage should be of a maximum size and be oriented towards pedestrian rather than vehicles.
- Building design must consider all façades. All façades should respond to their context.
- Penthouse materials and design should be integrated into the overall building form.
- Blank walls along property lines where new taller developments are adjacent to existing parking or smaller-scaled buildings are to be avoided and designed with high-quality materials.

4.1.5 Sustainable Building Design

New developments should incorporate the City of Toronto's Green Development Standards calling for the integration of environmental sustainability principles from the early design phase through to implementation. The City's recommendations included in the Green Development Standards will be mandatory to the extent that the City can legally require.

Key considerations for the design of new buildings include: water quality, consumption and runoff; the preservation of natural and built features; the reduction of hard surfaces, and reductions in the building footprint to create open spaces and landscaped areas. Other key considerations for achieving sustainable building designs are outlined in the City's Green Development Standards and include:

- Building orientation
- Sustainable landscape design
- Urban heat island mitigation
- Stormwater management
- Alternate transportation options
- Renewable energy
- Green roofs
- Building envelope design
- Natural ventilation
- Day light design
- Dark sky design
- Waste management
- Water use reduction and waste water technologies



Reduction of hard surfaces will discourage large amounts of stormwater runoff.



Usable green roofs provide environmental benefits, while improving amenity space for residents.

4 design guidelines

4.2 Vehicular Movement: Parking & Access

The guiding principle for the Avenue Road study area should be to develop a fine-grain of buildings with a continuous street wall to foster a pedestrian-oriented environment. In order to establish this more urban character, surface parking should be limited and located to the rear of buildings. Many design solutions are available to ensure the provision of adequate parking facilities without creating surface parking areas that are visible from the street other than parallel parking on the roadside. Depending on a development's density and site-specific opportunities, parking solutions will range from rear lane dedicated parking areas to integrated below-grade parking structures.

4.2.1 Vehicular Access

Appropriate vehicular access to new developments will be especially important in the Avenue Road Study Area. Cut-through traffic is seen as an on-going problem by area residents. Wherever possible, measures should be taken to discourage vehicles from using local neighbourhood streets for through trips. Many of the existing developments along Avenue Road are accessed both from Avenue Road as well as the side streets. Wherever possible, turning restrictions and driveway design should be used to discourage vehicles associated with new buildings from using the local streets. Access will need to be reviewed on a site-by-site basis.

- Vehicular access to parking, laneways and servicing and loading areas should occur on the east-west, side streets.
- Side street driveways serving buildings on Avenue Road should be designed and regulated to require that vehicles exiting are directed toward Avenue Road and away from the existing neighbourhood. By-lawed turn restrictions and channelizations are to be used wherever practical.
- Traffic calming measures could be used on local streets to discourage cut-through traffic. An area traffic study and consultation program should be carried out in the short term to determine the appropriate strategies.



Access to below-grade parking should be located off side streets to reduce curb-cuts on Avenue Road.



Structured parking should be integrated into building designs.

4.2.2 Structured Parking

- Below-grade parking structures or structures integral to buildings are the recommended alternative to surface parking.
- All new below-grade structured parking should locate vehicle access points on the least busy of the surrounding streets and/or off of rear lanes, in order to minimize curb cuts and reduce conflicts with pedestrians on Avenue Road frontage. Vehicular entrances shall not be located directly off of the Avenue Road frontage.
- Pedestrian access to structured parking should be clearly demarcated, highly visible and incorporated into the overall design of the building.
- Above-grade parking structures are discouraged. All new above-grade parking structures associated with new development should be completely integrated into the buildings, and form part of the overall development scheme so as to 'blend-in' with the surrounding buildings and not 'read' as a parking facility.
- Structured parking located within new developments should include some short-term public parking available for retailers and customers. This should be mandated by the Toronto Parking Authority/Green P.



Where surface parking is necessary, it should be screened from adjacent properties with landscaping (except where parking is shared) and pedestrian walkways should be clearly demarcated.

4.2.3 Surface Parking

- Surface parking in front of buildings should be prohibited.
- New and existing developments should consider the provision of centralized and shared off-site parking areas to provide required parking spaces that cannot be accommodated on-site.
- All new developments should locate all surface parking areas at the rear of buildings to ensure the sidewalks/pathways and building façades effectively define the street edge. In situations where it is impossible to accommodate surface parking behind buildings, small, discrete parking areas may be provided along the side(s) of buildings. In both scenarios, the parking areas should be appropriately screened from view.
- Any surface parking provided for developments at corner sites should not face onto or be visible from the street corner and/or intersection.
- Design of surface parking lots should adhere to guidelines set out in the City's "Design Guidelines for Greening Surface Parking Lots" and "Green Development Standards".



4 design guidelines

4.2.4 Servicing & Loading

Retail-oriented streets, such as Avenue Road, require the provision of service and loading facilities. Currently, many smaller retailers do not have dedicated servicing and loading facilities and trucks use the parking bays for short-term parking. As sites get developed, combined servicing and loading facilities must be easily accessible to ensure organized deliveries and pick-ups. In order to ensure a safe and pedestrian-focused public realm, it is essential to identify less visible areas for their location.

- It is recommended that these functions be accommodated along new rear service lanes or from side streets.
- Service areas in new developments should not face onto or be visible from streets, public spaces, landscaped open spaces and/or amenity areas.
- In all new developments, the required service areas should be located and designed as an integral part of the building and/or site design, and not located as separate, stand-alone areas or structures.
- In all new developments, utility facilities and spaces for the storage of goods and refuse should be internal to the main building(s).
- In all new developments where servicing and loading are not contained entirely within the building,

designated areas for storage, temporary truck parking, refuse collection and compaction, and loading should have a minimum separation of 10 metres from any public street, sidewalks and pedestrian walkway and a minimum separation of 10 metres from any residential properties.

- If internal/integrated service areas are not achievable within new developments, the service areas should be located to avoid visibility from public areas and/or be designed with appropriate screening measures and materials to shield all sides of the service area from public view. This includes gas and water meters, garbage and delivery areas.
- On new and existing developments where service areas require screening, the building materials used on the screening enclosure should be similar and/or complementary to those of the building's exterior materials and finishes. Low-maintenance landscaping treatments (providing year-round screening capabilities) may be considered a suitable screening device only when no other alternatives are possible. Building materials not suitable for service area screening include: unfinished wood, metal cladding and concrete block.



Service and loading areas should be screened by appropriately designed walls or enclosures and should be integrated into building designs.

4.3 Streetscaping & Landscaping

The following recommendations for the public realm are made to improve the appearance and functionality of Avenue Road and to better serve the needs of pedestrians including local residents, visitors, business owners and patrons. Improvements to the public realm for pedestrians will also contribute to a more animated and vibrant streetscape.

Throughout the Avenue Study process, the width and character of the public realm, particularly sidewalks, was identified as being one of the key contributors to the character of the area. As Avenue Road redevelops it will be important that the functionality and aesthetics of adjacent sidewalks allow for informal (e.g. socializing) and formal (e.g. outdoor cafe spaces, retail display areas) gathering of community residents and visitors to the area.

This section of Avenue Road has undergone major streetscape reconstruction over the last two years, so this Study does not anticipate major streetscape improvements.

4.3.1 Sidewalks & Streetscaping

- Provide a minimum of 4.0 metres for all sidewalks along Avenue Road. Where this minimum width does not currently exist, the City should implement the setback at grade for new developments to provide for a widened sidewalk. Please refer to Section 3.6.3 for more detail.
- Consider locations for new tree plantings.

4.3.2 Landscaping

- Ensure that street trees are planted with appropriate width and soil volume in continuous tree trenches as identified by the City standard, to allow for growth and to ensure their long-term viability. Watering systems and/or responsibilities should be established prior to planting.

- Use only species that are tolerant of urban conditions such as salt, poor soil and uneven irrigation. Monocultures should be avoided and tree selection should be context dependant, i.e. trees selected for areas with landscaping on one side and paving on the other should be different from trees selected for an area with paving on both sides.
- Tree selection should be considerate of retail uses and pedestrian traffic.
- Tree species should be consistent per block face.



Landscaping features will contribute to a more animated and vibrant streetscape.

4 design guidelines

4.3.3 Parks & Open Space

- New parks and green spaces are recommended in a number of locations:
 - Dunblaine Avenue R.O.W. (east of Avenue Road)
 - Roe Avenue TTC loop
 - Green Fingers (multiple locations)
 - Green Street Medians (multiple locations)
 - Green Public Lanes (multiple locations)
 - Improvements to the Douglas Greenbelt
 - Green Space in New Developments (to be determined)
 - Create and/or enhance visual and physical connections to existing or new open spaces along Avenue Road. This will enhance visibility of the park and open spaces and encourage use of neighbourhood parks and open spaces and create visibility to these spaces, thereby enhancing security.
- Refer to Section 3.3.1 through 3.3.7 for recommendations on open spaces.



Visual and physical connections will encourage increased use of parks and open spaces.

4.3.4 Public Art

- Refer to Section 3.5.1 through 3.5.4 for recommendations on locations for public art.
- Murals and community based art should be encouraged and supported on existing utility boxes and other unsightly infrastructure.
- Public art contributions should be sought from new development on the nine larger opportunity sites.
- Encourage public art for private development lands to add further interest to the Avenue Road streetscape.



Public art of varying scales may be appropriate for different locations along the Avenue Road study area. Larger pieces may be of an appropriate scale at the north end, closer to the Highway 401 on and off-ramps.

5 implementation

5.1 Implementation Recommendations

5.1.1 Zoning By-law and Official Plan Policies

Currently the City's zoning restrictions act as a disincentive to reinvestment and intensification within this section of Avenue Road. Almost 50% of the existing buildings along this stretch of Avenue Road exceed the currently allowable 1x density.

The community and property owners are faced with an unpredictable rezoning process. The recommendation of this report is that the City's zoning be updated to reflect a more feasible and therefore defensible, framework. Acceptable densities, heights and urban form that reflect economically viable redevelopment will improve the prospects for owners and allow the community to accurately anticipate where larger buildings will be acceptable and what those buildings will look like. The recommended zoning and policy amendments for Avenue Road are as follows:

Increase allowable height to five-storeys along the length of Avenue Road.

All sites may be developed to a maximum height of five storeys or 16.5 metres. All buildings should reflect the setbacks and stepbacks as indicated in Section 3.6.1.

Increase allowable height to six or seven storeys on the nine larger sites outlined in Section 3.6.2.

The massing envelopes for the nine larger opportunity sites should be included in the Zoning By-law. These sites will also have to adhere to the setbacks and stepbacks outlined in Section 3.6.1 and 3.6.2.

Increase permitted density

Increase permitted density to 3x for the entire Avenue Road study area.

Create an Official Plan Amendment for Douglas Greenbelt
Create an Official Plan Amendment to designate all of the Douglas Greenbelt lands as public open space.

Create an Official Plan Amendment for side street C1

To allow for side street commercial to remain, but only in house form and/or scale.

Amend Sign By-law

A prohibition on rooftop billboards will prevent any new rooftop billboards from legally being located along this stretch of Avenue Road.

Amend By-law 1-83

To allow home occupation in the broader study area.

5.1.2. Other Recommendations

Through the course of this study, a number of recommendations came forward that should be pursued by the City. These include:

Adoption of Urban Design Guidelines

To ensure the character and built form of new development and redevelopment will occur in a positive and sustainable manner, the City should adopt urban design guidelines for Avenue Road between Lawrence Avenue West and Wilson Avenue. The guidelines outlined in this document provide direction on the design and integration of new developments into the existing fabric of Avenue Road. The guidelines make recommendations on building and site elements such as minimum sidewalk widths, building stepbacks (from building face) and set-backs (from property lines), preferred building materials, ground floor design, parking, environmental sustainability and other elements.

Paid Public Parking included in new developments

Public parking spaces should be introduced into the parking structures of new developments. As the larger sites begin to be redeveloped there will be a loss of public or retail parking, and this should be replaced and enhanced in new developments. Partnerships with the City of Toronto's Parking Authority should be encouraged as a means of expanding public parking spaces especially for patrons of local business. These may take the form of both structured parking and surface parking areas located at the rear of new development.

Other recommendations include:

- Purchase land to provide an access from the Douglas Greenbelt to Glengarry Street to create a southerly access (Section 3.3.5);
- Acquire the Roe TTC Loop when declared surplus for the creation of a public park (Section 3.3.1);
- Investigate closure of the Dunblaine Avenue right-of-way at Avenue Road to create a park. Some residents on Dunblaine Avenue were informally surveyed about closing-off the street and indicated support for this proposal (Section 3.3.1);
- Consult City divisions regarding opportunities to improve, landscape and maintain leftover areas of open space within the public right-of-way to develop and construct the "green fingers" (Section 3.3.2);

- Prepare a Public Realm Study for Avenue Road to consider all of the improvements recommended to the Public Realm (the City would prepare this document);
- Conduct an area traffic study to identify problems and measures to discourage cut-through traffic and improve pedestrian safety on local streets east and west of Avenue Road (Section 3.7.4);
- Preserve the front setbacks on Avenue Road north of Melrose Avenue (Section 3.6.3); and
- Designate Avenue Road in the City's Public Art Master Plan (Section 3.5.1).

5.2 Community-City Partnerships

5.2.1 Community Association

There is currently no Business Improvement Association in this section of Avenue Road. From previous experience and the responses to the retail survey conducted during the course of this project, it is unlikely that one will be formed. There are three ratepayers association in the surround area, Ledbury Ratepayers Association, Bedford Park Ratepayers Association and the Old Orchard Ratepayers Association. The Associations are deeply involved in community issues and the Avenue Road corridor and will continue to be so. There is however, interest in a "Community Association" from both residents and some business representatives. The Councillor's office has committed to assisting interested community representatives in this endeavour. A number of LAC members have also expressed interest in participating.

Likelihood of implementation of many of the recommendations in this report would be greatly enhanced if a Community Association were to be formed. Other initiatives that could be taken on by the Community Association include:

- Design and maintenance of the green fingers;
- Solicitation of funding or donations to contribute to public art or gateways;
- Design review committee to work with the City on reviewing development applications;
- Branding initiatives to promote the "Upper Avenue"; and
- Coordinated street furniture site plan review.

5.2.2 Design Review

Transparency in the development process is essential to the acceptance and support of new development on Avenue Road and the input provided by design professionals in the community will help build community support. Outside of the typical review process, additional steps should be taken to ensure community involvement and awareness, including ongoing website updates, regular publications in local newspapers and partnerships with local community groups.

5.3 Ongoing Monitoring & Evaluation

This document will be made available to the LAC and the public to continue the transparent process by which this project has been conducted. This report will be forwarded to the Community Council with the staff implementation report.

Over time, the City of Toronto will need to amend their policies based on experience, trends and feedback from stakeholders. It is essential that a monitoring process be established to review the success of each new development project upon its completion. This review should inform the implementation of the next project to ensure that new buildings respond to changing conditions in the area.