

LYM Temporary Parking				
	A	B	Existing	Total
grd floor	176	85	34	295
deck	90	55		145
TOTAL				440

Accessible Parking			
4 for first 100			4
2% after 100			7
TOTAL			11

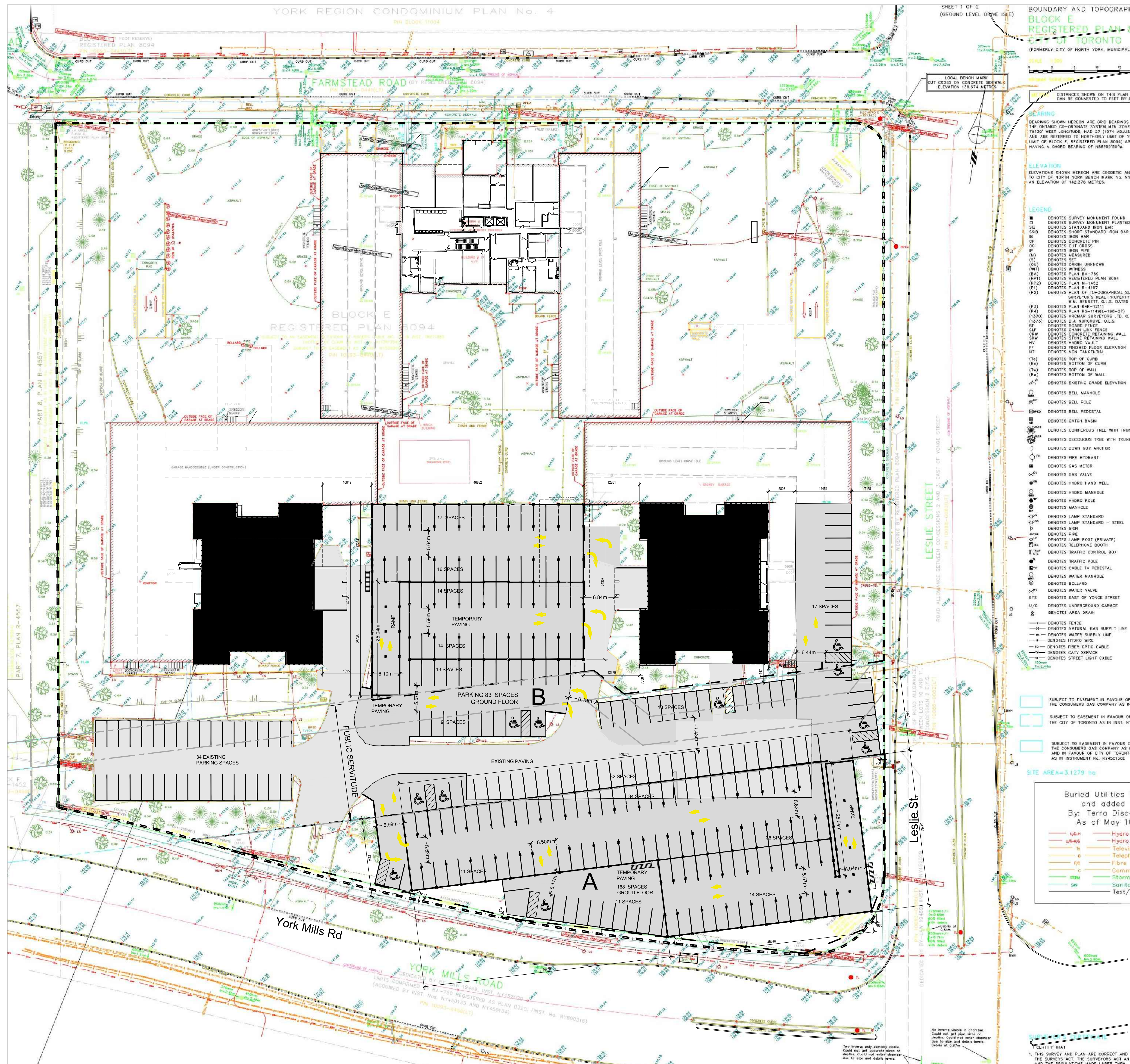
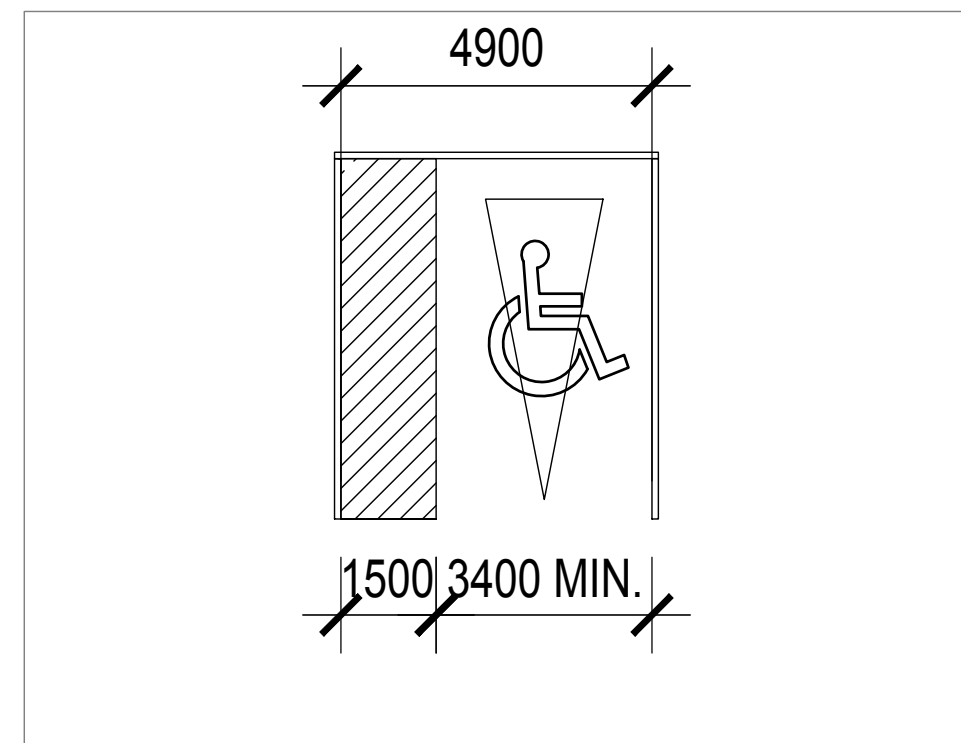
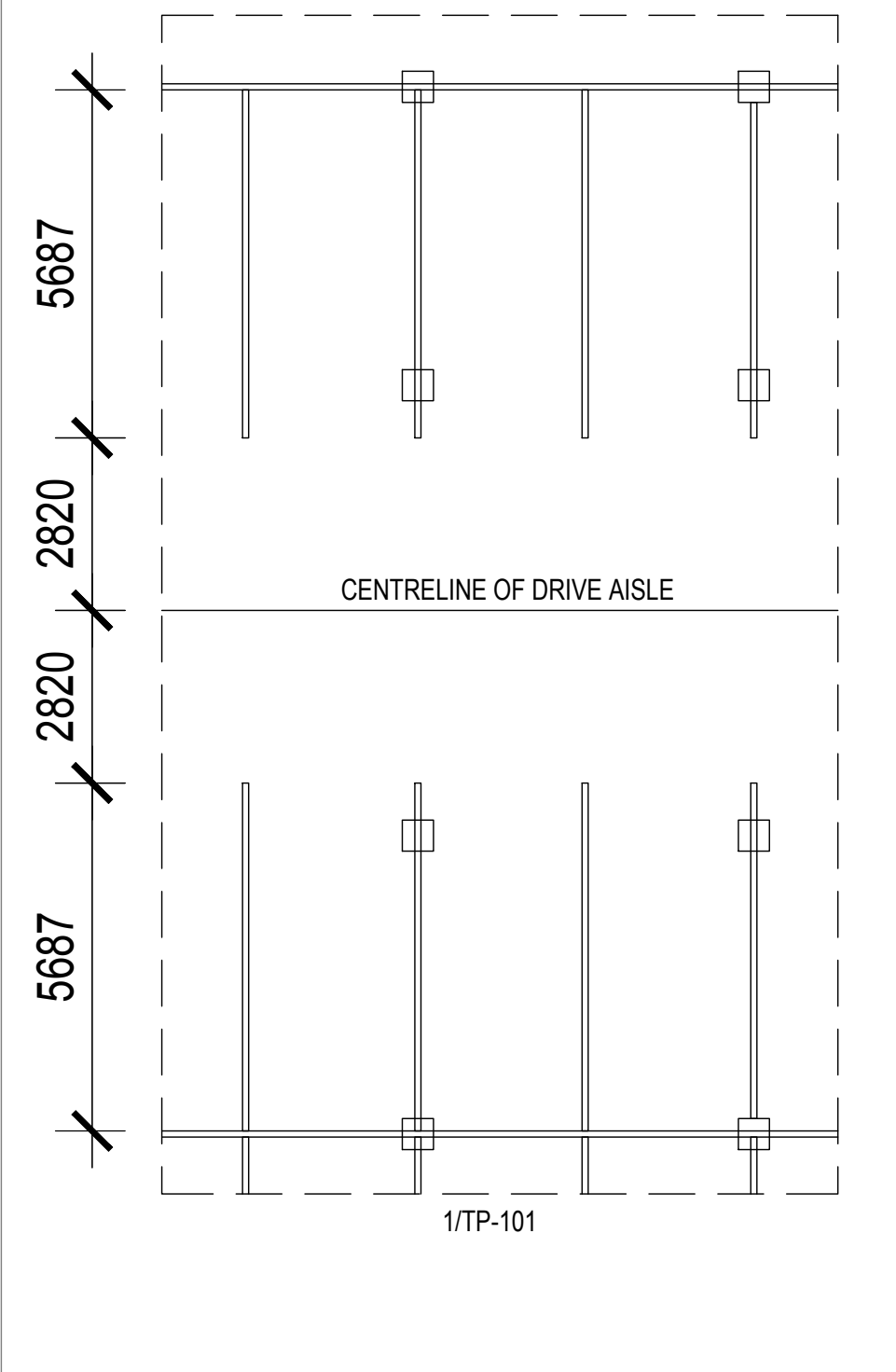

BOUNDARY AND TOPOGRAPHIC BLOCK E REGISTERED PLAN 8094 CITY OF TORONTO
(FORMERLY CITY OF NORTH YORK, MUNICIPALITY OF YORK)

LOCAL BENCH MARK CUT CROSS ON CONCRETE SEWERIAL ELEVATION 138.674 METRES

DISTANCES SHOWN ON THIS PLAN ARE IN METRES UNLESS OTHERWISE SPECIFIED

BEARINGS
BEARINGS SHOWN HEREON ARE GRID BEARINGS AND THE ONTARIO COORDINATE SYSTEM WITH ZONE 18. NORTHING AND EASTING COORDINATES ARE REFERRED TO NORTHERLY LIMIT OF 100° W. LIMIT OF BLOCK E REGISTERED PLAN 8094 AS SHOWN HAVING A CHORD BEARING OF N80°55'50"W.

ELEVATION
ELEVATIONS SHOWN HEREON ARE GEODETIC AND ARE TO CITY OF NORTH YORK BENCH MARK NO. N12704 AN ELEVATION OF 142.378 METRES.

LEGEND

- DENOTES SURVEY MONUMENT FOUND
- DENOTES SURVEY MONUMENT PLANNED
- SB DENOTES STANDARD BOUNDARY
- SB DENOTES SHORT STANDARD IRON BAR
- SB DENOTES IRON BAR
- CP DENOTES CONCRETE PIN
- CP DENOTES IRON PIPE
- (M) DENOTES MEASUREMENT
- (S) DENOTES SET
- (O) DENOTES ORIGIN UNKNOWN
- (WT) DENOTES WITNESS
- (EA) DENOTES PLAN EA-120
- (RP) DENOTES REGISTERED PLAN 8094
- (RP) DENOTES PLAN M-1402
- (P1) DENOTES PLAN E-4197
- (P2) DENOTES PLAN OF TOPOGRAPHICAL SURVEY SURVEYOR'S REAL PROPERTY SURVEY W.M. BENNETT, O.L.S. DATED SEPT 1923
- (P3) DENOTES PLAN RS-1149(L-190-23)
- (L1370) DENOTES HIGHLAND SURVEYORS LTD. O.L.S.
- (L1373) DENOTES D.J. HORGROVE, O.L.S.
- SLF DENOTES CHAIN LINK FENCE
- SLF DENOTES BRICK RETAINING WALL
- SLF DENOTES STONE RETAINING WALL
- HT DENOTES FINISHED FLOOR ELEVATION
- HT DENOTES NON-TANGENTIAL
- (Tc) DENOTES TOP OF CURB
- (Bc) DENOTES BOTTOM OF CURB
- (Tw) DENOTES TOP OF WALL
- (Bw) DENOTES BOTTOM OF WALL
- EX DENOTES EXISTING GRADE ELEVATION
- BM DENOTES BELL MANHOLE
- BP DENOTES BELL POLE
- BP DENOTES BELL PEDESTAL
- BP DENOTES CATCH BASIN
- BT DENOTES CONIFEROUS TREE WITH TRUNK DIA.
- BT DENOTES DECIDUOUS TREE WITH TRUNK DIA.
- DA DENOTES DOWN GUY ANCHOR
- FM DENOTES FIRE HYDRANT
- GM DENOTES GAS METER
- GV DENOTES GAS VALVE
- HM DENOTES HYDRO HAND WELL
- HM DENOTES HYDRO MANHOLE
- HM DENOTES HYDRO POLE
- HM DENOTES MANHOLE
- LS DENOTES LAMP STANDARD
- LS DENOTES LAMP STANDARD - STEEL
- LS DENOTES SIGN
- LS DENOTES PIPE
- LS DENOTES LAMP POST (PRIVATE)
- LS DENOTES TELEPHONE BOOTH
- LS DENOTES TRAFFIC CONTROL BOX
- LS DENOTES TRAFFIC POLE
- LS DENOTES CABLE TV PEDESTAL
- LS DENOTES WATER MANHOLE
- LS DENOTES BOLLARD
- LS DENOTES WATER VALVE
- EVS DENOTES EAST OF VONGE STREET
- U/G DENOTES UNDERGROUND GARAGE
- AD DENOTES AREA DRAIN
- FD DENOTES FENCE
- NGS DENOTES NATURAL GAS SUPPLY LINE
- WSL DENOTES WATER SUPPLY LINE
- HW DENOTES HYDRO WIRE
- FOC DENOTES FIBER OPTIC CABLE
- CSS DENOTES CITY SERVICE
- SLC DENOTES STREET LIGHT CABLE

Subject to Easement in Favour of the Consumers Gas Company as in Inst. N1450132

Subject to Easement in Favour of the City of Toronto as in Inst. N1450133

Subject to Easement in Favour of the Consumers Gas Company as in Inst. N1450133 and in Favour of City of Toronto as in Instrument No. N1450130E

SITE AREA=3.1279 ha

Buried Utilities as and added to By: Terra Discover As of May 10,

- UGM Hydro: Pri
- UGM Hydro: Sec
- N Television
- TS Telephone
- FOC Fibre Opt
- COMM Common
- SS Storm: Se
- SW Sanitary
- Text/ Sy

CERTIFY THAT
1. THIS SURVEY AND PLAN ARE CORRECT AND IN ACCORDANCE WITH THE SURVEYORS ACT AND THE REGULATIONS MADE UNDER THEM.

The Architect does not retain the consultants and therefore is not responsible for the accuracy of survey, structural, mechanical, electrical, etc. engineering information shown on the drawing. Refer to the appropriate engineering drawings before proceeding with work.

Contractor shall verify and check all dimensions and conditions on site prior to starting any of the work and report any discrepancy to the Architect and consultants before proceeding. Construction must conform to all applicable Codes and Requirements of Authorities having jurisdiction pertaining to this application.

No investigation has been undertaken or reported on by this office in regards to the environmental condition or pollution of this site.

This drawing is not to be scaled.

All dimensions and areas to be confirmed on site by Ontario Land Surveyor.

COPYRIGHT 2011 RAFAEL + BIGAUSKAS ARCHITECT INC.

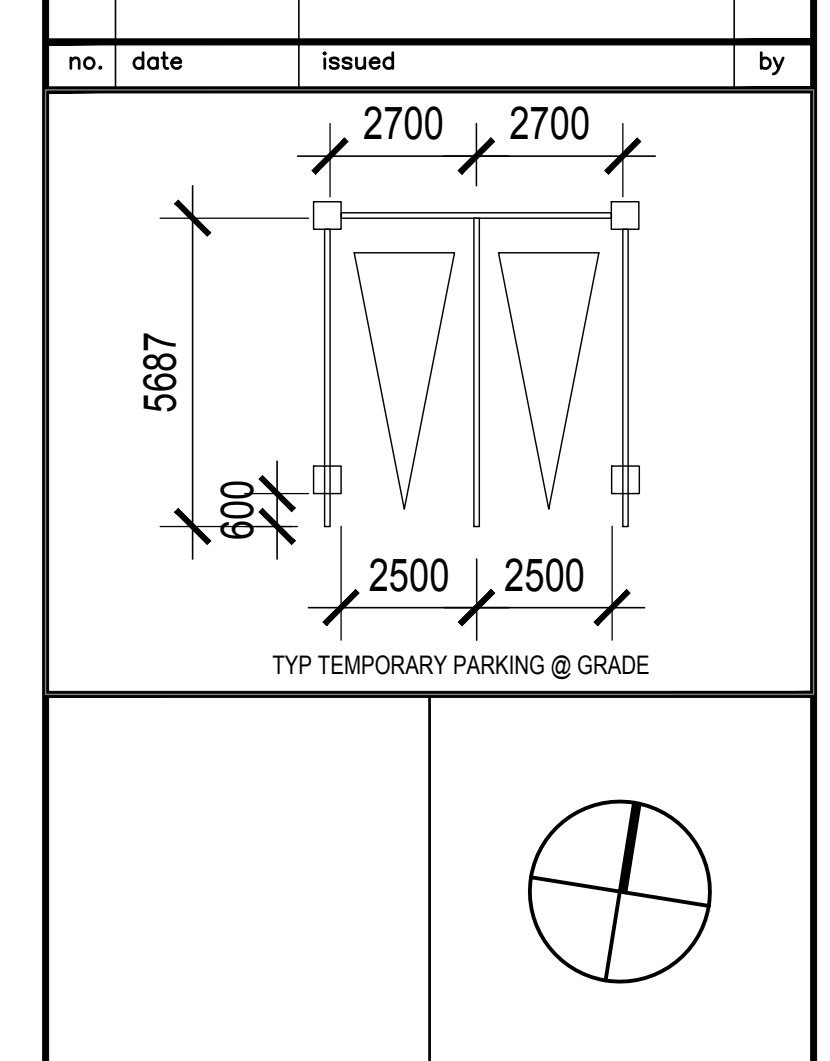

project title

LESLIE & YORK MILLS

RAFAEL+BIGAUSKAS ARCHITECTS

1140 Sheppard Ave. West, Unit 1, Toronto, Ontario M3K 2A2
Telephone:(416) 398-7500 Fax No.(416) 398-8956

sheet title

TEMPORARY PARKING GROUND FLOOR

scale 1:400

project no. **09-116**

date July 2018

drawn by checked by

date plotted July 27, 2018

drawing no. **TP-101**

date printed

Drawing name: P:\09-116\Yorkmill & Leslie\1.0 Design\Current\Sheet\Res\VA_06_7_Temporary Parking_Grd_Deck.dwg
Drawing file: A:\06_7_Temporary Parking_Grd_Deck.dwg
Jul 27, 2018 12:35pm

