



REPORT FOR ACTION

Alterations to Designated Heritage Property at 140 Merton Street

Date: October 24, 2019

To: Toronto Preservation Board
Planning and Housing Committee

From: Senior Manager, Heritage Preservation Services, Urban Design, City Planning

Wards: Ward 12 - Toronto - St. Paul's

SUMMARY

This report recommends that City Council approve the proposed alterations for the designated heritage property at 140 Merton Street, in connection with a City-initiated Zoning By-law Amendment and the proposed redevelopment of the site as part of the City's Housing Now Initiative.

As authority to enter a Heritage Easement Agreement ("HEA") has been provided per City of Toronto By-law 1021-2017, the report provides a recommendation that such HEA be executed and registered on title prior to final Site Plan Approval at 140 Merton Street which is designated under Part IV of the Ontario Heritage Act.

A City-initiated zoning by-law amendment will be presented to City Council in December 2019 with the goal of creating new affordable housing units on City-owned lands. The Housing Now Initiative for the 140 Merton Street property proposes to develop the site as a seniors' rental building with community space on the ground and second floor levels. Specifically, the project consists of an 18-storey mixed-use building consisting of 180 residential units, with a target of delivering 100% of the units as affordable seniors housing. The project will include over 2,000 square metres of community service space. The proposed development also includes a total of 45 parking spaces located in a one level underground parking garage.

The heritage property will be completely retained in situ for 12 metres of depth from the street facing façade. The project will not significantly impact the three dimensional form of the building as viewed from the public realm. Should the alterations to the subject property be approved, staff recommends that the leaseholder of the City-owned property be required to enter into a HEA and register it on title for the lands municipally known as 140 Merton Street in order to ensure the long-term protection of the heritage property.

RECOMMENDATIONS

The Senior Manager, Heritage Preservation Services, Urban Design, City Planning recommends that:

1. City Council approve the alterations to the heritage property at 140 Merton Street in accordance with Section 33 of the *Ontario Heritage Act*, to allow for alterations, with such alterations substantially in accordance with plans and drawings prepared by Montgomery Sisam Architects Inc., dated September 3, 2019, and on file with the Senior Manager, Heritage Preservation Services and the Heritage Impact Assessment (HIA), dated July 4, 2019, prepared by ERA Architects Inc., and on file with the Senior Manager, Heritage Preservation Services, all subject to and in accordance with a Conservation Plan satisfactory to the Senior Manager, Heritage Preservation Services, and subject to the following additional conditions:

a. That the related site-specific Zoning By-law Amendment permitting the proposed alterations has been enacted by City Council and has come into full force and effect in a form and with content acceptable to City Council, as determined by the Chief Planner and Executive Director, City Planning, in consultation with the Senior Manager, Heritage Preservation Services.

b. That prior to final Site Plan approval for the development contemplated for 140 Merton Street, the leaseholder of the City-owned property shall:

1. Execute and register on title the Heritage Easement Agreement with the City, pursuant to City of Toronto By-law 1021-2017 for the heritage property at 140 Merton Street, substantially in accordance with plans and drawings prepared by Montgomery Sisam Architects Inc., dated September 3, 2019, submitted with the Heritage Impact Assessment prepared by ERA Architects Inc., dated July 4, 2019, subject to and in accordance with the approved Conservation Plan required in Recommendation 1.b.2, all to the satisfaction of the Senior Manager, Heritage Preservation Services, and registered on title to the satisfaction of the City Solicitor;

2. Provide a detailed Conservation Plan prepared by a qualified heritage consultant that is substantially in accordance with the conservation strategy set out in the Heritage Impact Assessment for 140 Merton Street, prepared by ERA Architects Inc., dated July 4, 2019, all to the satisfaction of the Senior Manager, Heritage Preservation Services;

3. Provide final site plan drawings substantially in accordance with the approved Conservation Plan required in Recommendation 1.b.2 to the satisfaction of the Senior Manager, Heritage Preservation Services;

4. Provide a Heritage Lighting Plan that describes how the exterior of the heritage property will be sensitively illuminated to enhance its heritage character to the satisfaction of the Senior Manager, Heritage Preservation

Services, and thereafter shall implement such Plan to the satisfaction of the Senior Manager, Heritage Preservation Services;

5. Provide an Interpretation Plan for the subject property to the satisfaction of the Senior Manager, Heritage Preservation Services, and thereafter shall implement such Plan to the satisfaction of the Senior Manager, Heritage Preservation Services;

6. Provide a detailed Landscape Plan for the subject property satisfactory to the Senior Manager, Heritage Preservation Services.

c. That prior to the issuance of any permit for all or any part of the property at 140 Merton Street, including a heritage permit or a building permit, but excluding permits for repairs and maintenance and usual and minor works for the existing heritage building as are acceptable to the Senior Manager, Heritage Preservation Services, the leaseholder of the City-owned property shall:

1. Provide building permit drawings, including notes and specifications for the conservation and protective measures keyed to the approved Conservation Plan required in Recommendation 1.b.2, including a description of materials and finishes, to be prepared by the project architect and a qualified heritage consultant to the satisfaction of the Senior Manager, Heritage Preservation Services;

2. Provide a Letter of Credit, including provision for upwards indexing, in a form and amount and from a bank satisfactory to the Senior Manager, Heritage Preservation Services, to secure all work included in the approved Conservation Plan, and approved Interpretation Plan; and

3. Provide full documentation of the existing heritage property at 140 Merton Street, including two (2) printed sets of archival quality 8" x 10" colour photographs with borders in a glossy or semi-gloss finish and one (1) digital set on a CD in tiff format and 600 dpi resolution keyed to a location map, elevations and measured drawings, and copies of all existing interior floor plans and original drawings as may be available, to the satisfaction of the Senior Manager, Heritage Preservation Services.

d. That prior to the release of the Letter of Credit required in Recommendation 1.c 2. above, the leaseholder of the City-owned property shall:

1. Provide a letter of substantial completion prepared and signed by a qualified heritage consultant confirming that the required conservation work and the required interpretive work has been completed in accordance with the Conservation Plan and Interpretation Plan and that an appropriate standard of conservation has been maintained, all to the satisfaction of the Senior Manager, Heritage Preservation Services; and

2. Provide replacement Heritage Easement Agreement photographs to the satisfaction of the Senior Manager, Heritage Preservation Services.

FINANCIAL IMPACT

There are no financial implications resulting from the adoption of this report.

DECISION HISTORY

The property at 140 Merton Street, the War Amputations of Canada (War Amps) building, was designated on March 9, 2017 under City of Toronto by-law 1020-2017 under Part IV, Section 29 of the *Ontario Heritage Act* for its cultural heritage value, and meets Ontario Regulation 9/06, the provincial criteria prescribed for municipal designation under all three categories of design, associative and contextual value. See Attachment 2 for Property Statement of Cultural Heritage Value and Heritage Attributes.

<https://www.toronto.ca/legdocs/bylaws/2017/law1020.pdf>

In March 2017, authority was provided for the entering into a Heritage Easement Agreement for the conservation of the property known municipally as 140 Merton Street. Per City of Toronto By-law 1021-2017, City Council enacted:

<https://www.toronto.ca/legdocs/bylaws/2017/law1021.pdf>

BACKGROUND

Housing Now Overview

Housing Now is a new city-building approach to use City-owned lands to build affordable housing within mixed-use, mixed-income, complete communities. Initiated by City Council in December 2018, the Housing Now Initiative is intended to accelerate the development of affordable housing across Toronto.

The first phase of the Housing Now Initiative includes 11 City-owned properties, including 140 Merton Street, with the potential to create approximately 10,000 new residential units. A minimum two-thirds of all residential units across the properties will be purpose-built rental housing with at least 50% of the rental units providing affordable rental housing with rents set at 80% of Toronto's average market rent. The new affordable rental units will remain affordable for 99 years, providing quality housing opportunities for future generations.

City staff will present a recommended Zoning By-law Amendment for 140 Merton Street to Planning and Housing Committee's meeting on December 10, 2019. The recommendations will reflect work undertaken by City and CreateTO staff to prepare a development concept for 140 Merton Street as part of an inter-divisional review of architectural plans and a full suite of technical reports and in consultation with local and city-wide stakeholders.

This stage of work establishes a market-ready development concept, updates planning permissions, outlines the City's requirements for development and advances the project through key stages of the approvals process, providing the non-profit development partner selected in 2020 with greater certainty and an expedited route to construction and occupancy.

Development Concept Summary

The staff report to Planning and Housing Committee will recommend amendments to Zoning By-law 569-2013 that implement the development concept prepared through public consultation and inter-divisional review.

The development concept proposes the development of a mixed-use building at 140 Merton Street, comprising an 18-storey tall building set behind and integrated with the designated heritage property at 140 Merton Street. In total, the development would include approximately 15,000 square metres of residential and community space. The development concept is anticipated to provide 180 new rental units, with a target of delivering 100% of the units as seniors-oriented affordable rental. In addition, redevelopment of the site will provide over 2,000 square metres of community space, effectively doubling the existing leasable space used by SPRINT.

The proposed concept includes a five storey podium set 12 metres behind the front facade of the conserved heritage building. The tall building component rises to a total of 18 storeys plus the mechanical penthouse. The recommended Zoning By-law Amendment will establish design standards to shape the massing of the new building and specify the appropriate location of podium and tall building elements.

The development concept emphasizes opportunities to improve the public realm on Merton Street. A landscape plan has been developed, which, in combination with minimum setbacks, will guide the design of publicly-accessible and amenity spaces. Implementation of the plan will enable the creation of thoughtfully-designed, well-landscaped spaces that enhance the setting of the heritage property on site, provide gathering spaces for residents and visitors and advances the City Council-endorsed vision for the Merton Street public realm.

The development concept gives careful consideration to the parking required to serve the multiple uses on site. Underground parking is proposed at the rear of the site in a format that will not impact the conserved heritage building.

Lease Arrangement

The City may enter into a HEA with leaseholders of City-owned properties as contemplated under the *Ontario Heritage Act*. It is anticipated that the City will enter into a lease arrangement with a housing provider subsequent to the approval of the Zoning By-law Amendment and the coming into full force and effect of the Zoning By-law Amendment. The leaseholder will be required to enter into the HEA to implement the alterations as approved on this site.

Provincial Framework

Provincial Policy Statement and Planning Act

The Planning Act and the associated Provincial Policy Statement guide development in the Province. The Act states that municipalities must have regard for matters of provincial interest. Section 2(d) specifically refers to "the conservation of features of significant architectural, cultural, historical, archaeological or scientific interest."

The Provincial Policy Statement (PPS) issued under the authority of Section 3 of the Planning Act provides policy direction on matters of provincial interest related to land use planning and development. The PPS sets the policy foundation for regulating the development and use of land. Key objectives include: building strong communities; wise use and management of resources; and protecting public health and safety. The Planning Act requires that City Council's decisions affecting land use planning matters "be consistent with" the Provincial Policy Statement.

Policy 2.6.1 of the PPS directs that "Significant built heritage resources and significant cultural heritage landscapes shall be conserved." Properties included on the City's Heritage Register are considered to be significant in this context. "Conserved" is defined in the PPS as "the identification, protection, use and/or management of built heritage resources in a manner that ensures their cultural heritage value or interest is retained under the Ontario Heritage Act."

Policy 2.6.3 of the PPS directs that "planning authorities shall not permit development and site alteration on adjacent lands to protected heritage property except where the proposed development and site alteration has been evaluated and it has been demonstrated that the heritage attributes of the protected heritage property will be conserved."

Growth Plan

A Place to Grow: Growth Plan for the Greater Golden Horseshoe (2019) builds upon the policy foundation provided by the PPS and provides more specific land use planning policies to address issues facing the GGH region. The policies of the Growth Plan (2019) take precedence over the policies of the PPS to the extent of any conflict, except where the relevant legislation provides otherwise.

In accordance with Section 3 of the Planning Act all decisions of Council in respect of the exercise of any authority that affects a planning matter shall conform to the Growth Plan. Comments, submissions or advice affecting a planning matter that is provided by Council shall also conform to the Growth Plan.

Policy 4.2.7.1 of the Growth Plan states that "Cultural Heritage Resources will be conserved in order to foster a sense of place and benefit communities, particularly in strategic growth areas."

City of Toronto Official Plan

On May 12, 2015 the Ontario Municipal Board approved Official Plan Amendment 199 to the City of Toronto Official Plan Heritage Policies. This Amendment includes 53 heritage policies. Many of these policies are directly relevant to the proposed development. Relevant policies include:

3.1.5.3 Heritage properties of cultural heritage value or interest, including Heritage Conservation Districts and archaeological sites that are publicly known will be protected by being designated under the Ontario Heritage Act and/or included on the Heritage Register.

3.1.5.4 Properties on the Heritage Register will be conserved and maintained consistent with the Standards and Guidelines for the Conservation of Historic Places in Canada, as revised from time to time and as adopted by Council.

3.1.5.5 Proposed alterations, development, and/or public works on or adjacent to, a property on the Heritage Register will ensure that the integrity of the heritage property's cultural heritage value and attributes will be retained, prior to work commencing on the property and to the satisfaction of the City. Where a Heritage Impact Assessment is required in Schedule 3 of the Official Plan, it will describe and assess the potential impacts and mitigation strategies for the proposed alteration, development or public work.

3.1.5.6 The adaptive re-use of properties on the Heritage Register is encouraged for new uses permitted in the applicable Official Plan land use designation, consistent with the Standards and Guidelines for the Conservation of Historic Places in Canada.

3.1.5.26 New construction on, or adjacent to, a property on the Heritage Register will be designed to conserve the cultural heritage values, attributes and character of that property and to mitigate visual and physical impact on it.

3.1.5.27 Where it is supported by the cultural heritage values and attributes of a property on the Heritage Register, the conservation of whole or substantial portions of buildings, structures and landscapes on those properties is desirable and encouraged. The retention of façades alone is discouraged.

3.1.5.28 The owner of a designated heritage property will be encouraged to enter into a Heritage Easement Agreement where the City considers additional protection beyond designation desirable due to the location, proposed alteration, and/or the nature of that property.

Parks Canada Standards and Guidelines for Conservation of Historic Places in Canada

The Parks Canada Standards and Guidelines for the Conservation of Historic Places in Canada (Standards and Guidelines) is the official document guiding planning, stewardship and conservation approach for all listed and designated heritage resources within the City of Toronto. The General Standards (1-9) and the Standards for Rehabilitation (10-12) apply to this project.

COMMENTS

Assessment of Heritage Impacts

Heritage staff has reviewed the Heritage Impact Assessment, prepared by ERA Architects Inc. and submitted in conjunction with the Zoning By-law Amendment Application. The proposed Conservation Strategy for the site is rehabilitation. As defined by the Parks Canada Standards and Guidelines for the Conservation of Historic Places in Canada, rehabilitation is “the access or process of making possible a continued or compatible contemporary use of an historic place, or an individual component, while protecting its heritage value.” The intention is to maintain the existing community use and integrate the retained heritage building with compatible new construction. Staff are in support of the proposal for conformity with the Planning Act, the Provincial Policy Statement, the Growth Plan and the City's Official Plan heritage policies and the Standards and Guidelines for Conservation of Historic Places in Canada.

Building Retention

The property will be entirely retained in situ to a depth of 12 metres, measured from the primary south front wall of the heritage building. Further, all internal elements of the building and the roof are also proposed for retention.

Beyond the 12 metre cut line, the north portion of the heritage building as well as the later rear additions will be removed to facilitate the site excavation and construction of the new building. The Heritage Impact Assessment establishes that:

"the impact is mitigated by the retention, in situ, of the heritage building to a depth of 12 meters. This depth will ensure the three-dimensional integrity of the heritage resource is maintained. This retention line includes representative examples of each type of window. Further, this approach allows for the salvaging of original brick which can be used for masonry repair and conservation of the retained heritage fabric.

The rear portion of the side elevations with fenestration and its surrounds are identified as heritage attributes and will be removed. Notwithstanding, staff believe that the 12 metre depth of full building retention combined with enhanced landscaped setting surrounding the heritage property and transition of scale to the new housing project is an appropriate Conservation Strategy for the site.

Project Design Compatibility with Heritage Resource

Scale and Massing - The new building is proposed to have a five storey podium that provides a transition in scale between the base and tower that helps integrate the scale of the heritage building with the proposed development. The tower will be constructed

behind the heritage building and steps back from the face of the podium to provide additional separation. Horizontal and vertical articulation as well as cladding materials and finishes will be developed as part of the Site Plan Approval process.

Setbacks and Stepback - The utilization of setbacks and stepbacks permits unobstructed views of the east, south, and west facades. A small two storey element that articulates the podium element has been located 12 metres to the east of the retained heritage property. This feature is similar in height and form to the heritage building and creates an open space area between the new and old buildings.

Open Space - landscape open space is provided on three sides of the heritage building to ensure its visibility from the public right of way.

Proposed Conservation Strategy

The project proposes to rehabilitate the heritage property. It involves the retention in situ of the entire heritage building to a depth of 12 metres, measured from the primary street facing south facade. All heritage attributes within this 12 metre front portion (with side elevations) of the building will be retained and conserved.

The conservation scope applied to the retained building fabric includes masonry repairs and cleaning to address damaged and deteriorated areas of brick and stone. Along the south street facing side the conservation work includes reconfiguration of the existing accessibility ramp as part of the proposed landscape enhancements and retention and rehabilitation of the existing granite entrance landing and side walls with stainless steel handrail.

The existing aluminium windows will be replaced with a double-glazed thermally broken window, steel windows will be altered to accommodate a double glazed window and operable windows will be sealed for heightened performance. It is proposed to replace the windows and spandrel glass with upgraded matching materials, pattern and proportion of divisions. This approach will still maintain the appearance and proportion of the existing windows. On the east side, the windows do not appear original and it is proposed they be replaced to match the windows on the south elevation. On the west side, there are single glazed steel windows that will be conserved and upgraded with double glazing.

Staff are of the opinion that the proposed project plans appropriately conserve the cultural heritage value of the existing heritage property at 140 Merton Street, while allowing for its adaptive reuse. The impacts to the heritage resource on the site will be mitigated by the retention of substantial portions of the existing building and a conservation strategy that conserves and enhances the site's cultural heritage value. The proposed alterations are sympathetic to and conform with the City of Toronto's Official Plan Heritage Policies and the Standards and Guidelines.

Conservation Plan

Prior to final Site Plan approval for the proposed development at 140 Merton Street, staff are recommending that the applicant be required to provide a detailed

Conservation Plan to the satisfaction of the Senior Manager, Heritage Preservation Services, that fully describes how the cultural heritage values of the property at 140 Merton Street will be conserved.

Heritage Interpretation Plan

Heritage interpretation enhances personal experiences, increases respect and understanding, and communicates the importance of our cultural heritage properties.

Prior to final Site Plan approval for the proposed development at 140 Merton Street, staff are recommending that the applicant be required to provide a detailed Interpretation Plan to the satisfaction of the Senior Manager, Heritage Preservation Services that fully describes how the cultural heritage values of the property at 140 Merton Street will be interpreted.

Heritage Lighting Plan

Prior to final Site Plan approval for the proposed development, staff are recommending that the applicant be required to submit a Lighting Plan to the satisfaction of the Senior Manager, Heritage Preservation Services. This plan will provide details of how the heritage property will be lit to enhance heritage character as viewed from the public realm at night.

Landscape Plan

Should Council approve the proposed conservation strategy, staff are recommending that the applicant be required to provide a final Landscape Plan that enhances the heritage character of the property to the satisfaction of the Senior Manager, Heritage Preservation Services as a condition of final Site Plan approval.

CONCLUSION

Heritage Preservation Services staff have reviewed the proposed development for the designated heritage property at 140 Merton Street and are satisfied the proposal has regard to Section 2.d of the *Planning Act*, is consistent with the Provincial Policy Statement, conforms with the Growth Plan and conforms with the City of Toronto's Official Plan heritage policies in conjunction with the Standards and Guidelines for the Conservation of Historic Places in Canada.

CONTACT

Dan DiBartolo
Senior Heritage Planner, Heritage Preservation Services
Urban Design, City Planning
Tel: 416 338 5856 Fax: 416-392-1973
Email: dan.dibartolo@toronto.ca

SIGNATURE

Mary L. MacDonald, MA, CAHP
Senior Manager, Heritage Preservation Services
Urban Design, City Planning

ATTACHMENTS

Attachment 1 – Location Map
Attachment 2 – Reasons for Designation (Statement of Significance) and Attributes
Attachment 3 - Photos
Attachment 4 - Project Drawings

LOCATION MAP
140 Merton Street

ATTACHMENT 1

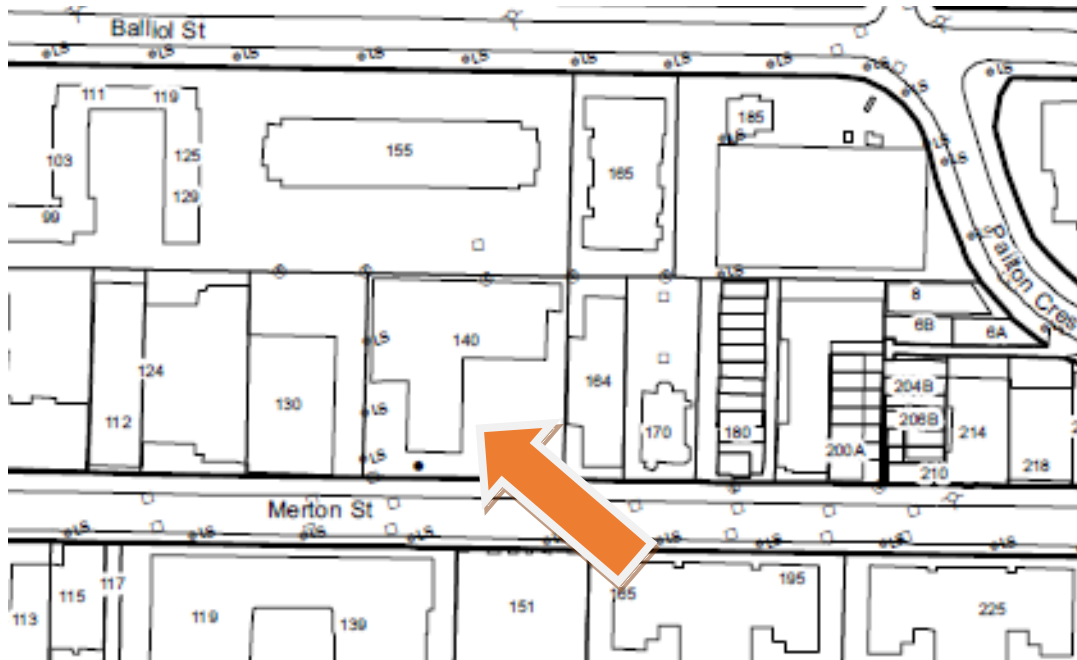

Location Map - Project Site is located on the north side of Merton Street. North is oriented upward.

The property at 140 Merton Street, the War Amputations of Canada (War Amps) building, is worthy of designation under Part IV, Section 29 of the Ontario Heritage Act for its cultural heritage value, and meets Ontario Regulation 9/06, the provincial criteria prescribed for municipal designation under all three categories of design, associative and contextual value.

Description

The property at 140 Merton Street is located on the north side of Merton Street between Yonge Street and Pailton Crescent and contains the former War Amps building which has been owned by the City of Toronto since 1994. A two-storey facility constructed in 1959-60 for the War Amps as their "Dominion headquarters" and key-tag manufacturing services, the building is clad in limestone, polished black granite and buff brick. In 1973, a single storey, buff brick-clad addition was constructed at the rear of the adjacent property to provide storage facilities. In 1985, two small additions were made at the second storey level on rear sections of the 1959-60 building which had originally been single storey. The front area of this adjacent property is now vacant and used for parking. The building is substantially set-back from the street and originally had planters along the principal (south) elevation adjacent to the main entrance, with a long walkway to the main entrance, flanked by designed areas for grass flanking parking spaces on the south and west sides. The parking in front of the building has been removed and replaced with planting including mature trees. Since 1995, a ramp constructed along the south elevation has enabled universal access.

Statement of Cultural Heritage Value

The former War Amps building has design value as an example of late Modern Classicism, a style favoured by public institutions and conservative corporations, here applied to a building designed for the employment of Canadian war amputees and their national headquarters. The design value is evident in the high degree of artistic merit seen in the combination of minimal and linear classical details, traditional materials such as limestone cladding, modern materials and elements such as polished black granite, curtain walling and the cast metal handrails which exhibit the combined influence of Streamlined Art Deco and 1950s automobile styling. Further, the tall, single, limestone-clad fluted pier at the west end of the principal (south) elevation of the building, has a quality evocative of a cenotaph, appropriate in honouring the sacrifice made by the war amputees in service to their country.

The property has associative value with the War Amps organization, founded in 1918 by amputee and army padre Lieutenant Colonel Sidney Lambert and chartered in 1920 as an organization of "amputees helping amputees" with both practical assistance and counselling. Their now nation-wide, key tag service was initiated in 1946 as a means for veterans to achieve independence through employment. The War Amps has expanded their services to include adults and children who have lost their limbs from causes other than war. Since 1998, the community service organization, SPRINT Senior Care has

been a tenant in the building. The property is also valued for its association with the Toronto architect Charles B. Dolphin (1888-1969), known for many fine landmark buildings in the city including the Postal Delivery Building (1939-1941).

Contextually, the War Amps building is valued as it contributes to maintaining the 1950s-1960s character and low-rise scale of the buildings fronting onto the north side of Merton Street between Yonge Street and Pailton Crescent. The building is historically linked to its surroundings as it was part of post-war transformation and re-development of the street following the completion of the Yonge Street subway line.

Heritage Attributes

The heritage attributes of the property at 140 Merton Street are:

EXTERIOR:

- The setback, placement and orientation of the building, mid-block on the north side of Merton Street between Yonge Street and Pailton Crescent
- The scale, form and massing of the original two-storey building.
- (This does not include the 1973 one-storey addition on the adjacent property or the 1985 additions at the second level above the original one-storey building sections)
- The materials, comprising limestone, black granite, buff brick and metal
- The elements on the principal (south) elevation including the main entrance located at the west side, with a bevelled, polished black granite door frame and base with the limestone cladding, the adjacent limestone fluted pier which rises above the parapet, and the curtain wall windows with their blue spandrel panels and surrounding limestone frame and the buff brick cladding at the eastern edge and parapet.
- On the side (west) elevation, the limestone-clad pier with a masonry pattern of large blocks and an incised frame surrounding the curtain wall double-storey window opening with metal frames and blue spandrel panel
- On the side (west) elevation to the north of the pier, the first ground floor window opening and its pattern of glazing with a central vertical mullion and narrowing opening sections at the top and bottom of the window set into the buff brick-clad wall
- On the side (east) elevation the portion of black granite base, the buff brick-clad elevation
- On the side (east) elevation, at the ground floor level, the two, wide window openings divided into seven sections with three low opening sections, in a pattern corresponding to the principal (south) elevation with cast stone sills
- On the side (east) elevation, at the upper level, the three windows, joined by a cast stone sill, with the first window divided in two equal sections and the next two windows, towards the rear of the property, divided into three equal sections of the same dimensions as the first window
- The projecting metal parapet cornice on the west, south and east elevations



140 Merton Street: photograph showing the principal (south elevation) and the west side of the property. At the rear of the property, the 1985 infill addition at the second floor level can be detected with the different coloured brick (HPS, 2016)



Front Façade close-up

PHOTOS
140 Merton Street



140 Merton Street: photograph showing the east side of the property as it faces the street. Note at the rear of the original building, the second-storey addition constructed in 1985 indicated by the different coloured brick, as well as the single-storey addition, at the rear of the parking lot completed in 1973. (HPS, 2016)

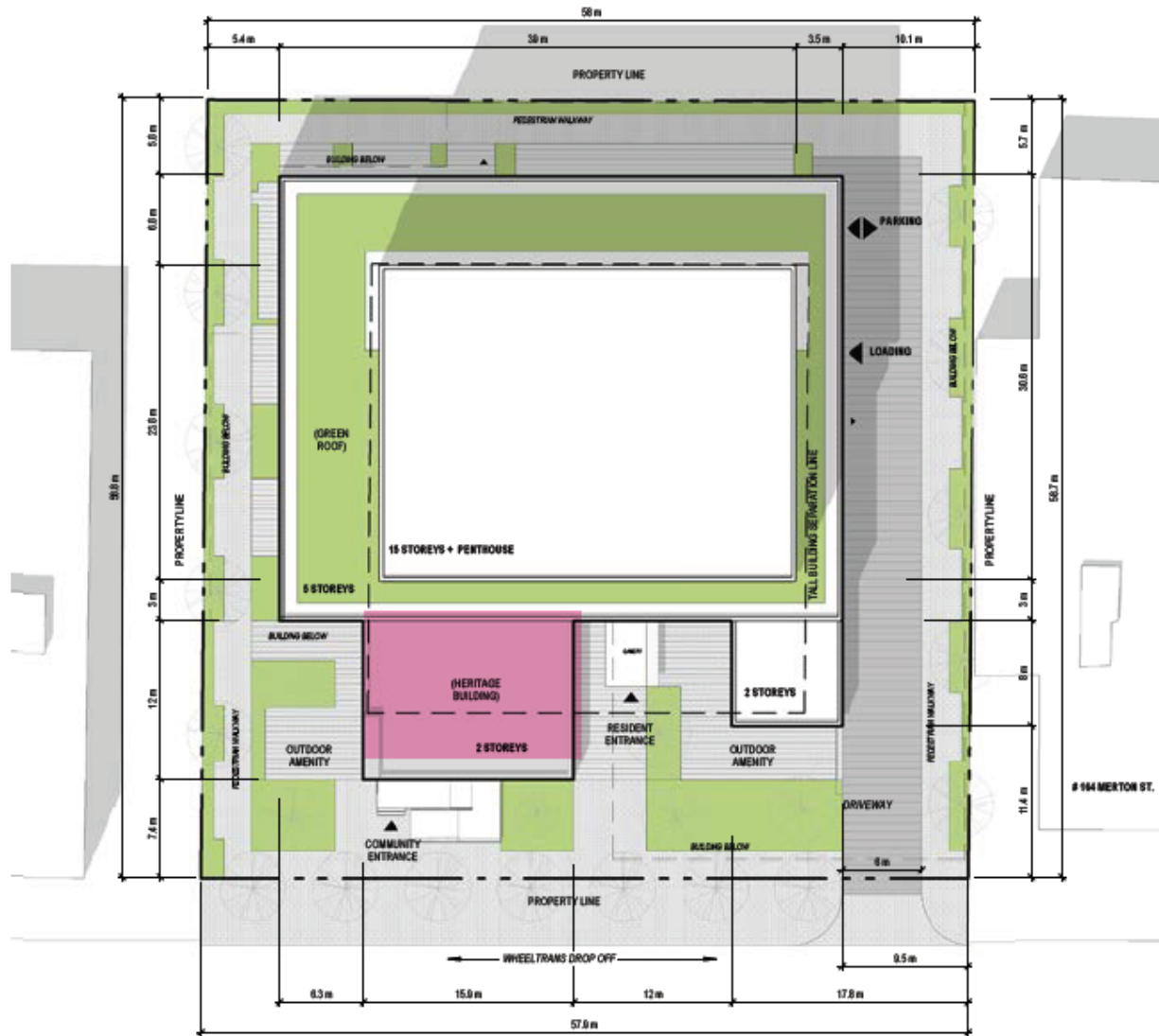

140 Merton Street - Site Plan (Conceptual)

DRAWINGS
140 Merton Street

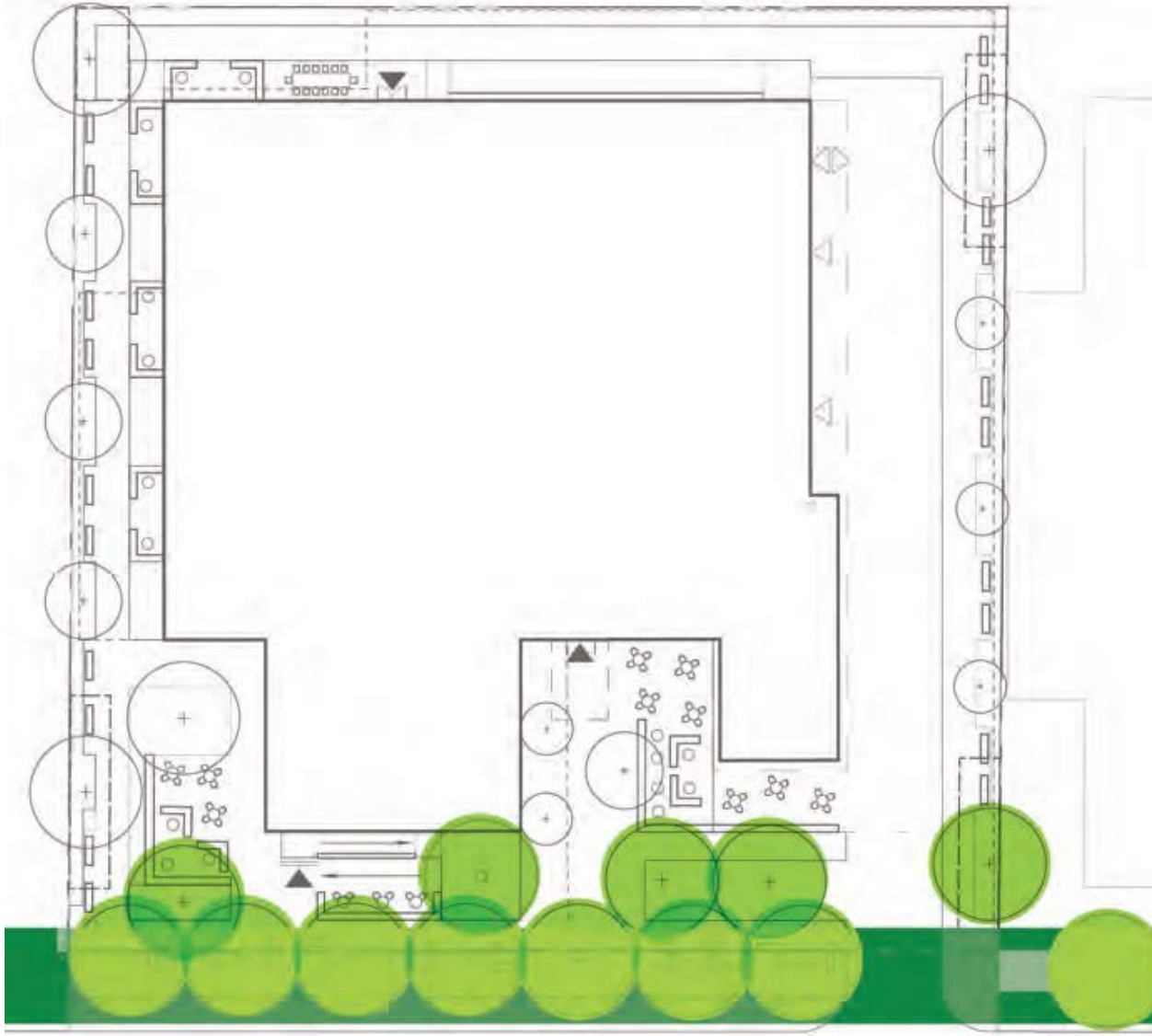

140 Merton Street - Landscape Plan (Conceptual)

DRAWINGS
140 Merton Street



East elevation, with area of removal in blue, excluded additions in white dashed line (ERA, 2019).



West elevation, with area of removal in blue (ERA, 2019).

140 Merton Street - Showing areas of removal beyond the 12 metre cut line

DRAWINGS
140 Merton Street

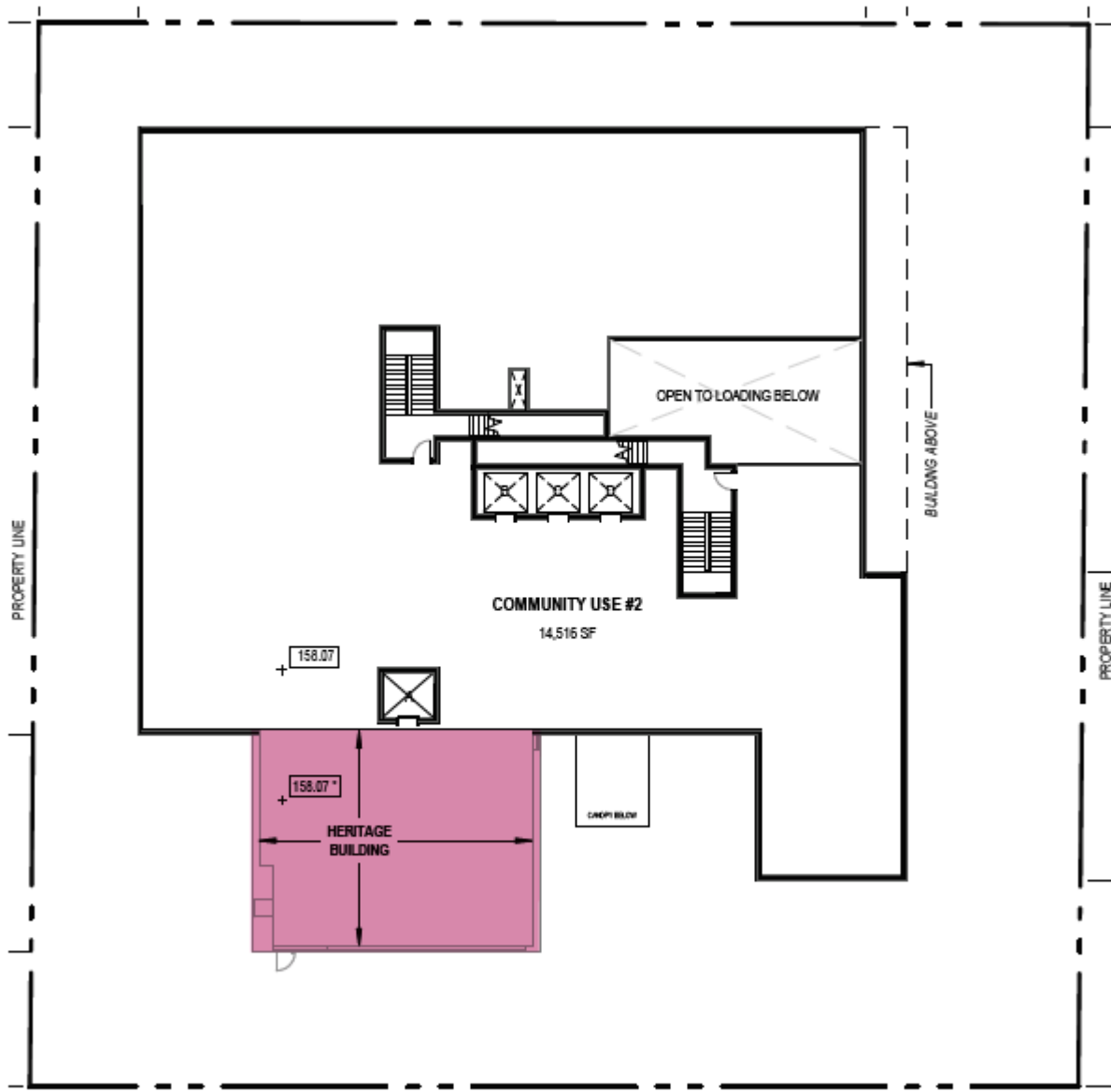

140 Merton Street - Second Floor Level (Conceptual)

DRAWINGS
140 Merton Street

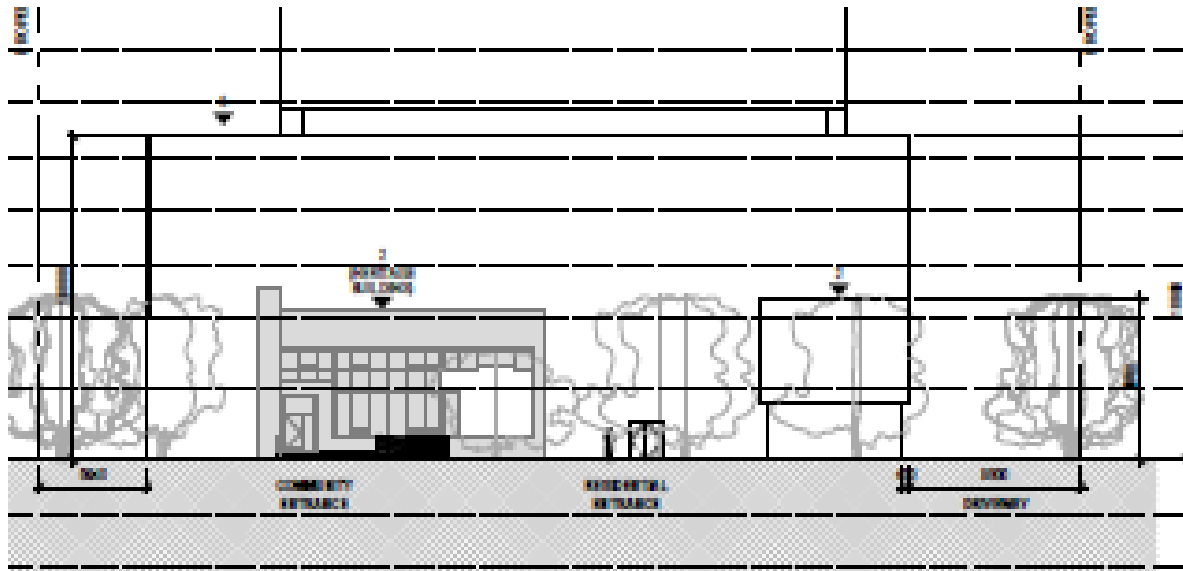

140 Merton Street - Front Façade Elevation (Conceptual)

DRAWINGS
140 Merton Street

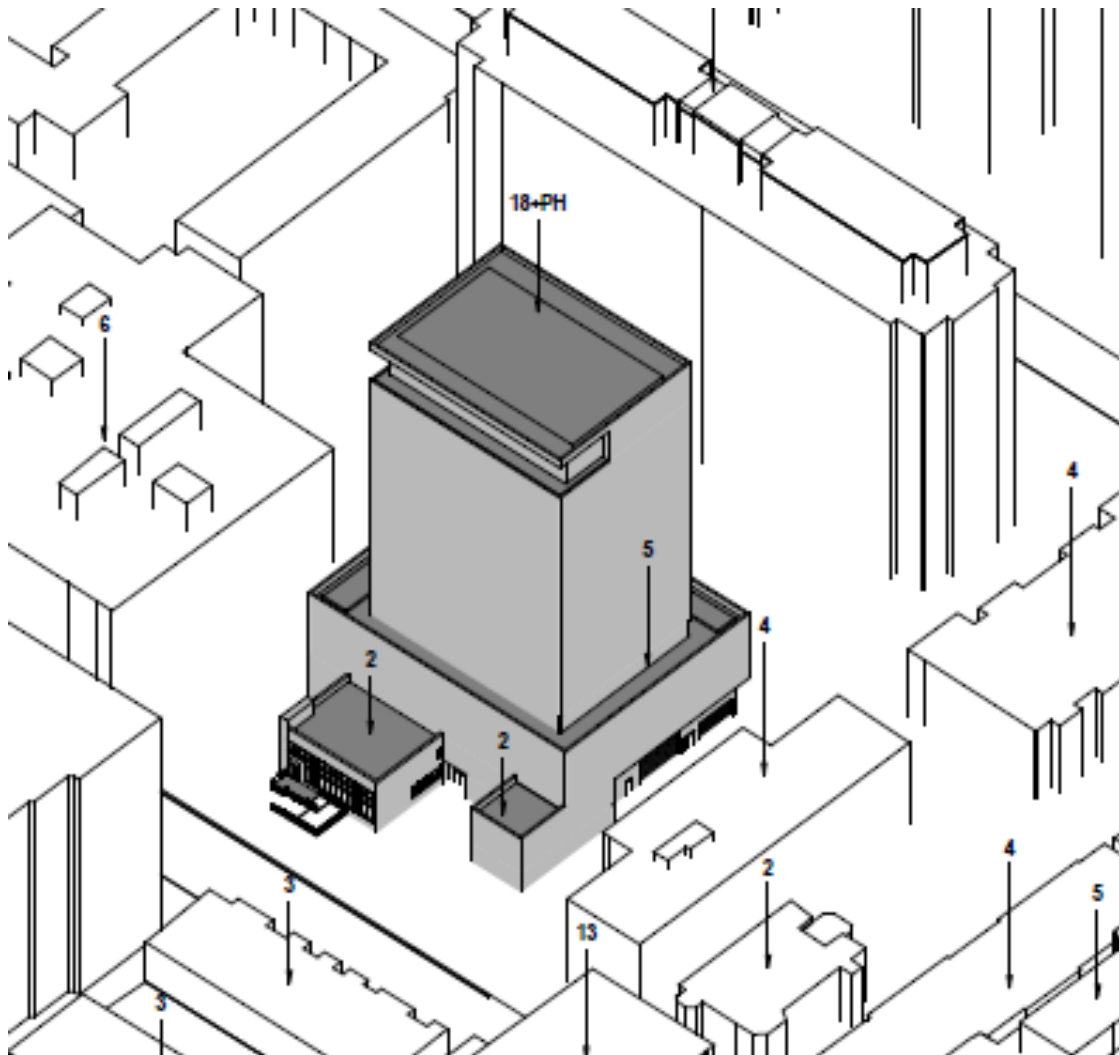

140 Merton Street - Massing Model (Conceptual)

DRAWINGS
140 Merton Street



140 Merton Street - Pedestrian View of Heritage Building with New Development (Conceptual)