

BARRIER CURB

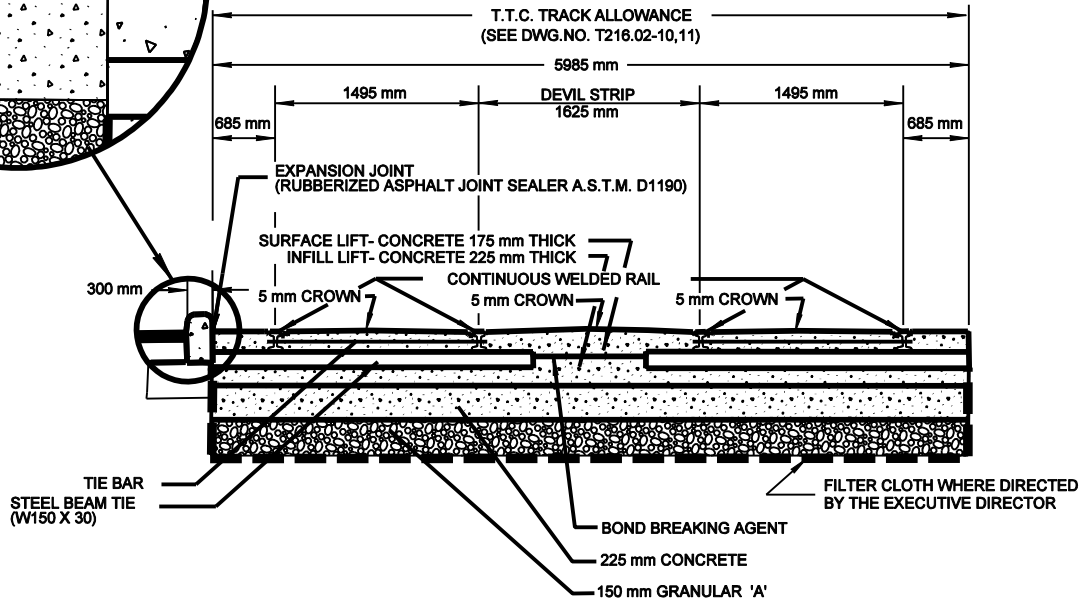

**AT GRADE
TYPICAL CROSS SECTION 'B'**

NOT TO SCALE

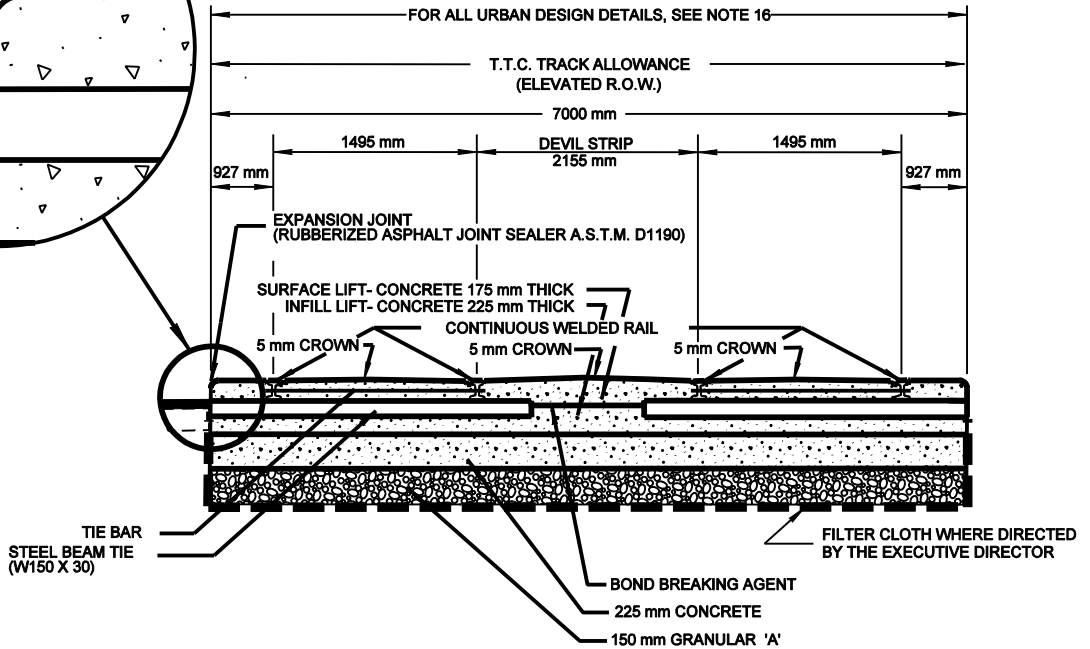
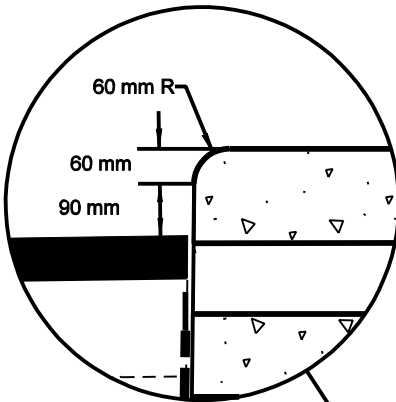

**ELEVATED R.O.W.
TYPICAL CROSS SECTION 'A'**

NOT TO SCALE