

TORONTO STAFF REPORT

January 24, 2005

To: Toronto and East York Community Council

From: W. (Wally) Kowalenko, City Surveyor, Works and Emergency Services

Subject: Naming of Public Lane Located East of Jones Avenue, Extending Southerly From Sproat Avenue
(Ward 30 - Toronto - Danforth)

Purpose:

This report recommends that the proposed public lane located east of Jones Avenue, extending southerly from Sproat Avenue, be named "Peyton Lane".

Financial Implications and Impact Statement:

There are no financial implications resulting from the adoption of this report.

Recommendations:

It is recommended that:

- (1) the public lane located east of Jones Avenue, extending southerly from Sproat Avenue, be named "Peyton Lane"; and
- (2) the appropriate City Officials be authorized and directed to take the necessary action to give effect thereto.

Background:

A request has been made by Michael Vaughan (130 Adelaide Street West, Suite 3100, Toronto, ON M5H 3P5) to name the public lane illustrated on Attachment No. 1. Naming the lane will facilitate identification of the existing and proposed residential buildings. The residents of the properties fronting the lane, at 17 Rear Sproat Avenue, 136 Rear Curzon Street and 166 Rear Curzon Street support the naming. An application is being made to the City for additional homes at 166 Rear Curzon Street.

Mr. Vaughan has requested the name “Peyton Place” to honour the memory of William Peyton Hubbard, Toronto’s first black alderman and acting mayor. Alderman Hubbard retired to 660 Broadview Avenue and his connection to Ward 30 is commemorated with a plaque in Riverdale Park. The name “Peyton” is proposed rather than “Hubbard”, to avoid confusion with Hubbard Boulevard in Ward 32, which was named after his son, Frederick Langdon Hubbard.

Comments:

The proposed name has been circulated for comment and is acceptable to Councillor Paula Fletcher, Police and Emergency Medical Services. Fire Services commented that the name is phonetically similar and in close proximity to Drayton Ave at Coxwell and Danforth. The Toronto and East York Preservation Panel prefers “Peyton Lane”, since “Peyton Place” may be associated with the 1960’s television show, instead of William Peyton Hubbard.

The proposed name “Peyton Lane” conforms with item 1 (c), Criteria For Name Selection, as set out in City Council’s street naming policy:

“to honour and commemorate noteworthy persons associated with the City of Toronto”.

Notices to name the lane, under the Municipal Act, 2001, will be given in accordance with the notice requirement set out in Chapter 162-3A of the City of Toronto Municipal Code.

The cost of the sign will be accommodated within the Transportation Services 2005 operating budget.

Conclusions:

The proposed name “Peyton Lane” is consistent with the City of Toronto Street Naming Policy approved by City Council at its meeting held on August 1, 2, 3 and 4, 2000 (Clause 9, Report 15 of the Works Committee) and should therefore be approved for identifying the public lane.

Contact:

Desmond Christopher, Supervisor, Street and Parcel Mapping
Phone: 416-392-1831, Fax: 416-392-0081; E-mail: dchristo@toronto.ca

W. (Wally) Kowalenko
City Surveyor

BH

File: 13CC-S

List of Attachments:

Attachment No. 1 – Map

Attachment No. 1

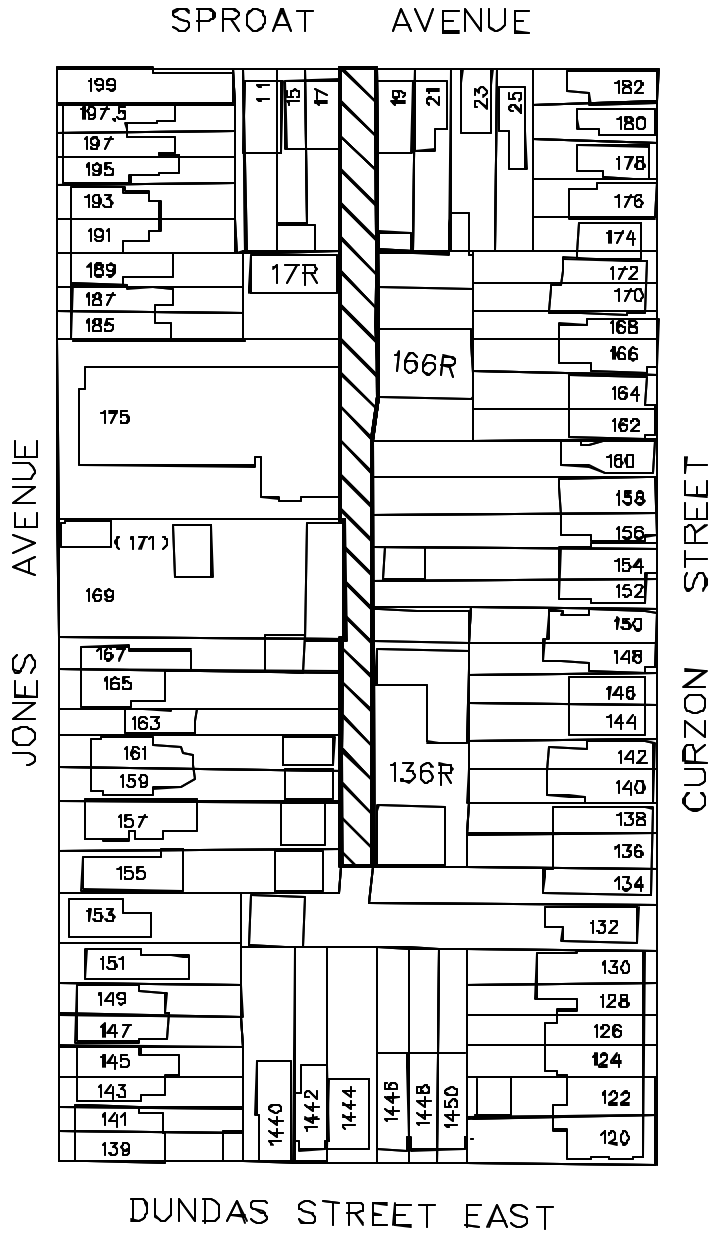

 PUBLIC LANE TO BE NAMED "PEYTON LANE"

WORKS AND EMERGENCY SERVICES
SURVEY AND MAPPING SERVICES
TORONTO JANUARY 21, 2006
PEYTON.DGN WARD 30
FILE:1902.22.30 MAP:52H-13
DRAWN:B.HALL

