

3.1.4

IPL Documents

Tab 1

Submitted by
Paul Richardson
Pres. & CEO-IPL



Michael Pacholok, Director

Purchasing and Materials Management Division
City Hall, 17th Floor, West Tower
100 Queen Street West
Toronto, Ontario M5H 2N2

Elena Caruso
Manager of Purchasing
Goods and Services

Via Email

April 18, 2013

Attn: Mr. Steve Boily
IPL Inc.
140, Commercial Street
Saint-Damien, QC G0R 2Y0
sboily@ipl-plastics.com

Dear Mr. Boily;

**Re: Request For Proposal No. 0401-13-3001
The Manufacture, Distribution & Maintenance of the Next Generation Green Bin
Functional Prototype Request**

Thank you for your response to the above Request for Proposal No. 0401-13-3001 for the Manufacture, Distribution & Maintenance of the Next Generation Green Bin

We wish to advise you that your firm's Main Proposal has passed the technical threshold during our evaluation and in accordance with Section 3.2 and evaluation Stage 2B, we formally request the following:

3.2 Evaluation Prototype Samples (products, commodities and materials)

"As it is the requirement of the Proponent to submit prototype sample(s) that meet the specifications noted in the RFP for evaluation, including that of Appendix E Stage 2B, and meet the design(s) submitted and evaluated under Appendix E Stage One (1) and 2A, The City reserves the right to perform its own prototype sample(s) evaluation to determine where samples, in part or in whole, deviate from specifications. The City reserves the right to request written verification as per section 3.1 of the specification, including but not limited to accredited laboratory test results to show proof of compliance to some or all specifications, all at no cost to the City.

Upon City evaluation, where prototype sample(s) are found to deviate from specifications as identified in Stage 2A and where said deviations are deemed by the City to be similar or better in design and construction to this specification, the City may accept said deviations.

Upon City evaluation, where prototype sample(s) are found to deviate from specifications and where said deviations are deemed by the City to not be similar or better in design and construction to this specification, City may request Proponent to rectify any deviations to meet specifications or declare prototype sample as rejected and may result in the proposal submission being declared non-compliant, see section 3.5 – Design Specification."

In accordance with evaluation Stage 2B, the City is requesting to verify and confirm the Bin design and functionality, full scale functioning prototypes will be requested from Proponents that meet the minimum



Michael Pacholok, Director

Purchasing and Materials Management Division
City Hall, 17th Floor, West Tower
100 Queen Street West
Toronto, Ontario M5H 2N2

Elena Caruso
Manager of Purchasing
Goods and Services

technical score. **Proponents must supply a prototype within 4 weeks of request**, at no additional cost to the City. Prototype offered must meet the design submitted and evaluated under Appendix E Stage 1 and Stage 2A. New designs replacing those designs originally submitted and evaluated under Appendix E Stage 1 and 2A will not be accepted and Proposal will be rejected.

To assist the City with the evaluation in a timely manner, we respectfully request delivery of your functional prototype as soon as possible and no later than Thursday, May 16, 2013.

If you require further information, please do not hesitate to contact Robert Babin, Supervisor, Corporate Purchasing at (416) 392-7178 or by email at rbabin@toronto.ca

Yours truly,

Elena Caruso, Manager
Goods and Services

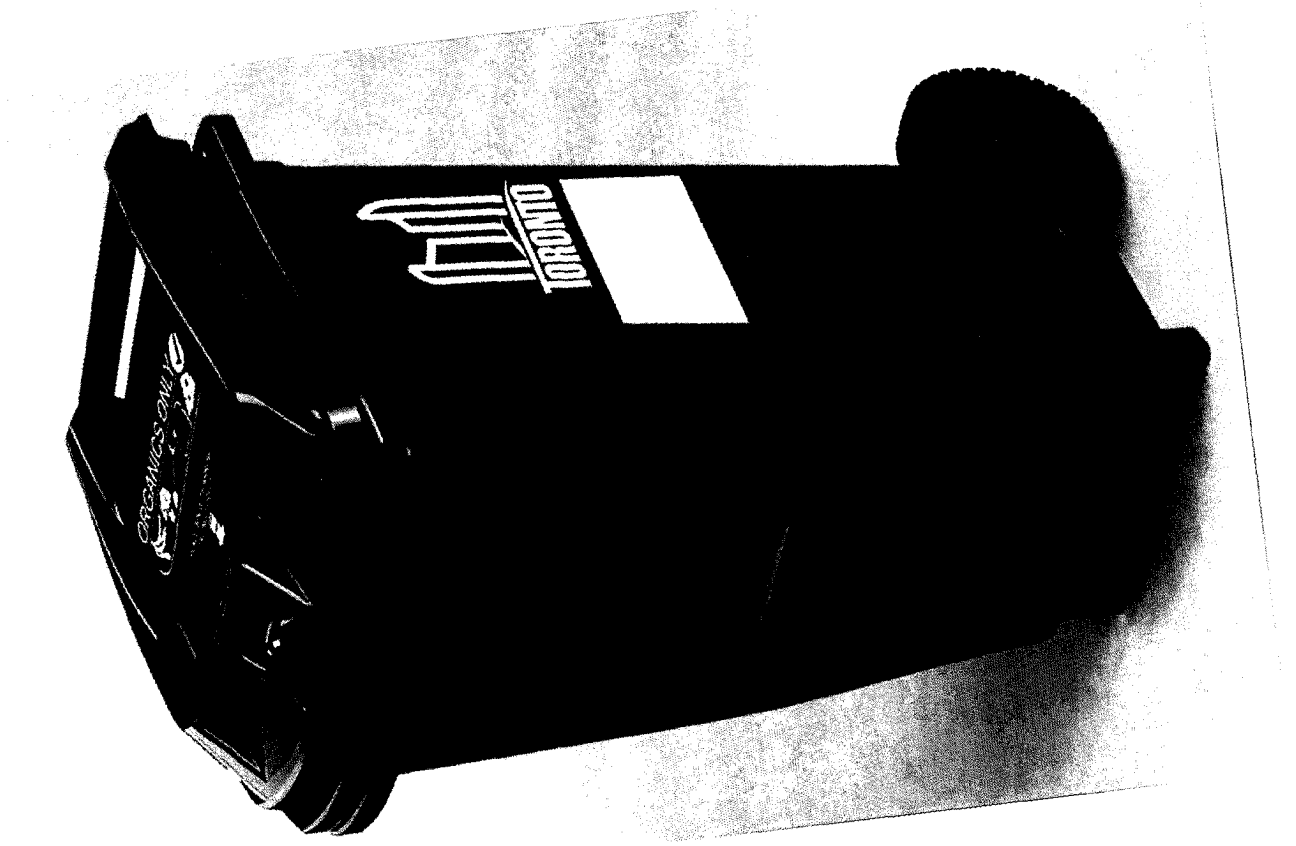

RFP 0401-13-3001 The Manufacture, Distribution & Maintenance of the Next Generation Green Bin - Réunion

Organisateur : Elena Caruso <ecaruso@toronto.ca> Envoyé : Wed 2013-05-29 3:08 PM

Objet : RFP 0401-13-3001 The Manufacture, Distribution & Maintenance of the Next Generation Green Bin

Emplacement : City Hall, 100 Queen Street West, East Tower, 25th floor

Début : Mon 2013-06-03 9:00 AM Journées entières

Heure de fin : Mon 2013-06-03 10:30 AM

As per RFP 0401-13-3001 for the Green Bin the City would like to meet with your firm to discuss the prototype submitted in response to the above noted RFP document as per section 5.5 of the RFP titled "Interviews or Demonstrations".

This process does not allow your firm to bring forward new information that was not already provided in your proposal response.

The City will have a set of questions relating to your proposal in which require clarification, specifically related to the prototype provided.

The meeting will commence promptly at 9:00 am end no later than 10:30 am.

Members of Solid Waste Team and Purchasing will be in attendance.

Please advise who from your team will be in attendance. Please confirm receipt of this invitation.

Elena Caruso
Manager, Goods and Services, Corporate Purchasing
City Hall, 17th Floor, West
100 Queen Street West
Toronto, Ontario
M5H 2N2
Tel: 416-392-7316
Fax: 416-392-8411
E-mail: ecaruso@toronto.ca

Démarrer | Calendrier - Boîte au... | Industrial BU April pr... | Microsoft Excel - Anal... | 5 Rappels - \\Distant | Présentation2 - Micro... | RE: Traitement des mon... | RFP 0401-13-3001 ... | 14:11

IPL

Grabber arms do not hit the back sides of the bin resulting in the bin not being secured on the lifter and it may slip into truck while dumping its contents.

Latch key is difficult to use. The key is small and it must be turned 180 degrees to open and is not easily opened with one hand.

The latch key guard area is small and will not allow individuals with gloves on to turn the key to open it, also would be difficult for those with large hands.

The bottom of the bin does not seem to have strong supports and may wear/break from repeated use overtime.

The bin body has many crevices that will trap material in and not dump properly, the crevices also makes it difficult to deposit larger bags into the bin and causes voids in the bin.

Moisture may get trapped in the lid lip/channel and in sub zero temperatures may freeze the lid to the bin.

Debris/moisture may attach to the lid latch pins or fall inside the latch causing it to fail.

De : Robert Babin [mailto:rbabin@toronto.ca]
Envoyé : June 17, 2013 2:35 PM
À : Steve Boily
Cc : Elena Caruso
Objet : Fwd: Next Generation Green Bin RFP Interview

Mr. Rouleau,

It was realized today that the 20th of June is actually Thursday of this week and not Wednesday as earlier communicated. As such, please be advised that the effective date for your response is verified as Thursday, June 20th, at 12 o'clock noon that your firm's response is required by.

We apologize for the confusion.

Regards,

Robert Babin
Supervisor, Corporate Purchasing
Purchasing and Materials Management Division
City of Toronto
17th Floor West Tower
100 Queen St. W.
Toronto, ON
M5H 2N2

(416) 392-7178 - Desk
(416) 392-8411 - Fax
rbabin@toronto.ca

1. Grabber arms do not hit the back sides of the bin resulting in the bin not being secured on the lifter and it may slip into truck while dumping its contents.

1- Grabber arms do not hit the back sides of the bin resulting in the bin not being secured on the lifter and it may slip into truck while dumping its contents.

Original shape

When grabbed the cart, the full automated Arm was only touching the 2 front corners

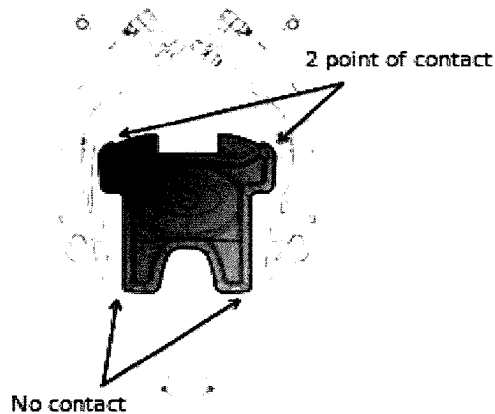

Adjusted shape

Now, the automated arms is touching on 4 all corners

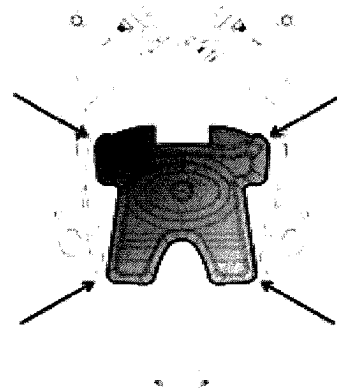

The above diagram illustrates the original and modified (adjusted) shape of IPL proposed City of Toronto's Next Generation Green Bin. As per the direction provided by the Selection Committee, IPL has made design changes to the cart that now enable a grabber arm to have (4) points of contact on the cart; improving from the (2) points of contact the City of Toronto identified during the prototype review stage. IPL is very confident that these design changes will ensure constant, (4)-point contact with the grabber arm/cart interface and result in consistent lifting and dumping cycles.

- 2. Latch key is difficult to use. The key is small and it must be turned 180 degrees to open and is not easily opened with one hand.

2- Latch key is difficult to use. The key is small and it must be turned 180 degrees to open and is not easily opened with one hand.

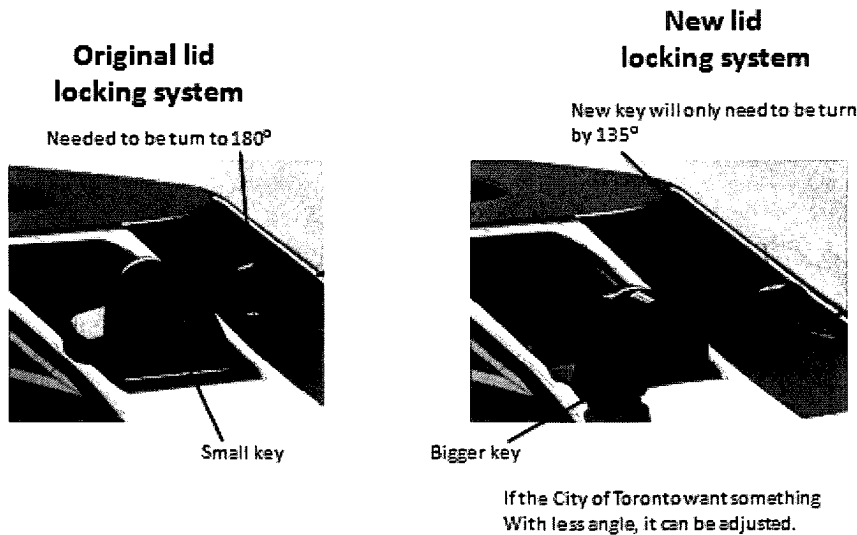

The Selection Committee identified that the proposed locking system (original) may cause City of Toronto operators difficulties in opening the latch with one hand, as the key head was too small, recessed in the latch housing and required a full 180° to open. IPL’s new design (New lid), results in a much larger key head, is situated outside of the latch housing and requires a 135° rotation to open the latch, allowing the latch to be opened with one hand. The amount of rotation can vary from 90° to 360° and IPL suggests that 135° meets both comfort (gloved-hand) and security (prevention of lid to easily open). If the City would like to change the degree of rotation, IPL is open to the City’s suggestions.

3. The latch key guard area is small and will not allow individuals with gloves on to turn the key to open it, also would be difficult for those with large hands.

3- The latch key guard area is small and will not allow individuals with gloves on to turn the key to open it, also would be difficult for those with large hands.

Original lid locking system

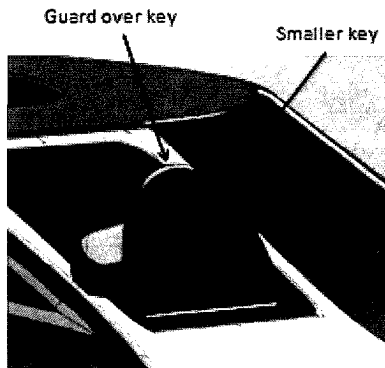

New lid locking system

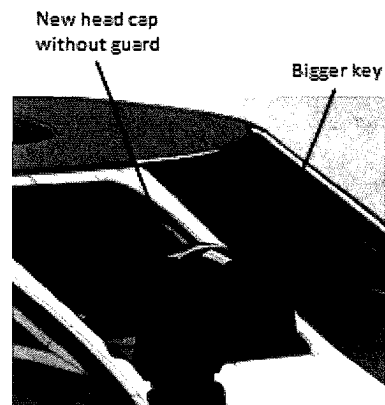

The Selection Committee identified that the proposed locking system (original) may cause City of Toronto operators difficulties in opening the latch when using a gloved- hand (winter collection), as the key head was too small, recessed in the latch housing and required a full 180° to open. IPL's new design (New lid), results in a much larger key head, is situated outside of the latch housing and requires a 135° rotation to open the latch.

4. The bottom of the bin does not seem to have strong supports and may wear/break from repeated use overtime.

4- The bottom of the bin does not seem to have strong supports and may wear/break from repeated use overtime.

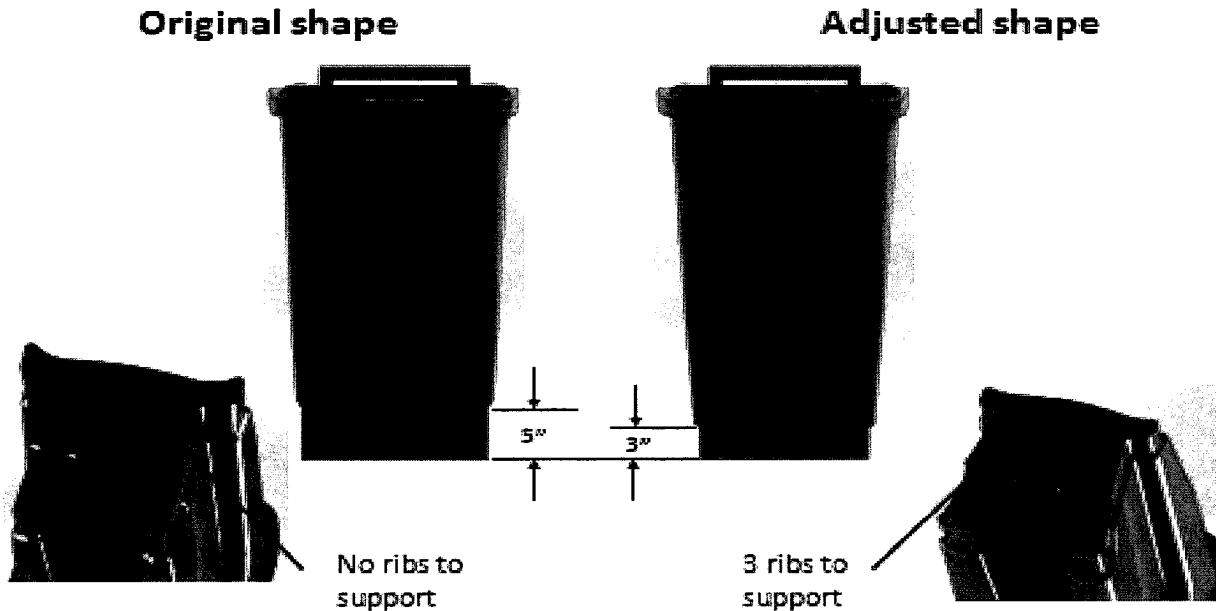

The Selection Committee identified a potential issue with the structural integrity of the bottom of the cart and speculated potential cart failures over repeated use and collection. IPL's original design (Original Shape) has been modified (Adjusted shape) to reduce the overall height of the flange from 5" to 3", as well as adding (3) support ribs to reinforce the flange. IPL is very confident that the new (Adjusted shape) design will significantly reduce the potential of breakage and/or cracking.

5. The bin body has many crevices that will trap material in and not dump properly, the crevices also makes it difficult to deposit larger bags into the bin and causes voids in the bin.

5- The bin body has many crevices that will trap material in and not dump properly, the crevices also makes it difficult to deposit larger bags into the bin and causes voids in the bin.

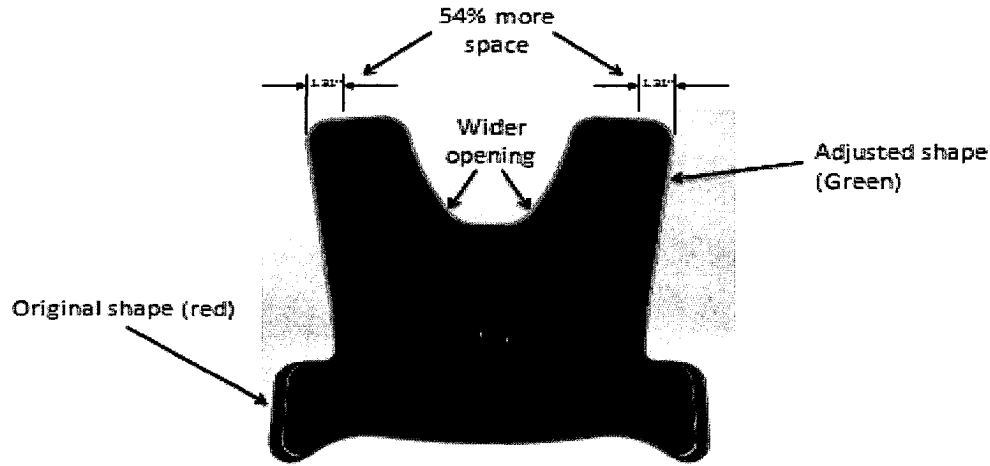

The Selection Committee identified potential areas in IPL’s original design (Original shape-red) that may result in material being trapped and ultimately not being dumped. IPL’s new design (Adjusted shape-green), has opened-up these areas (crevices) to allow for easier release of material and significantly reduced the potential for material to be trapped or remain in the cart after the dumping cycle has been completed.

6. Moisture may get trapped in the lid lip/channel and in sub-zero temperatures may freeze the lid to the bin.

6- Moisture may get trapped in the lid lip/channel and in sub zero temperatures may freeze the lid to the bin.

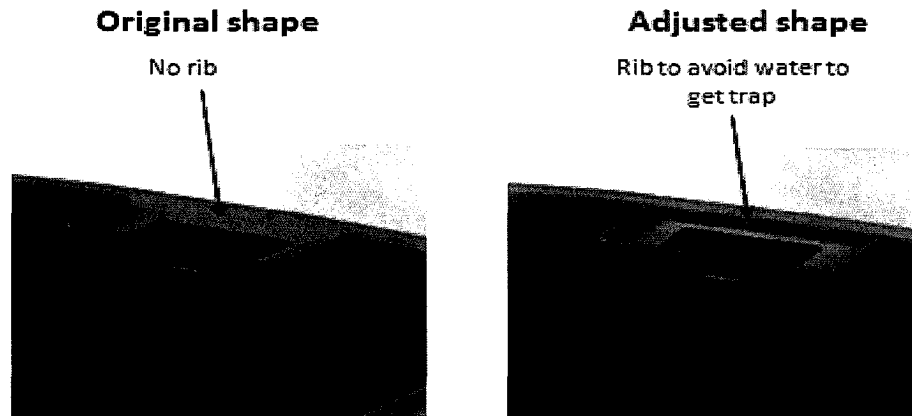

The Selection Committee identified IPL's original design (Original Shape) as potentially allowing moisture to be trapped and ultimately having this moisture freeze. IPL's new design (Adjusted shape), adds a rib, preventing moisture to collect and reduce the chance of freezing.

7. Debris/moisture may attach to the lid latch pins or fall inside the latch causing it to fail.

7- Debris/moisture may attach to the lid latch pins or fall inside the latch causing it to fail.

Original shape

Screws can block organic waste

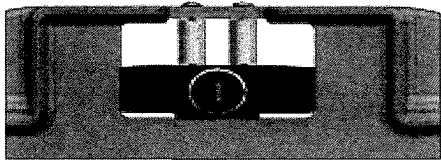

Adjusted shape

Screws have been move on each side
Leaving the hole without any obstruction

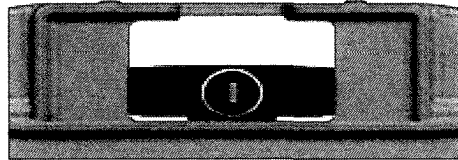

The Selection Committee identified that IPL’s original design (Original shape) was susceptible to having the attachment screws block organic material and result in an obstruction. The new design (Adjusted shape), has the attachment screws relocated and removes the possibility of organic material causing a blockage.

Conclusion

In summary, we believe the changes that have been proposed by the City of Toronto's Next Generation Green Bin Selection Committee to IPL have been beneficial and positive. Integrating these changes into the Bin has improved the overall design and functionality and this will ultimately better serve the residents of Toronto.



Elena Caruso, Manager
Goods and Services
(416) 392-7316

Michael Pacholok
Director

Purchasing & Materials Management Division
City Hall
100 Queen Street West
18th Floor, West Tower
Toronto, Ontario M5H 2N2

October 4, 2013

IPL Inc.
140 Commercial Street
Saint-Damien, QC
G0R 2Y0
Attention: Steve Boily

**Subject: Request for Proposal (RFP) 0401-13-3001
The Manufacture, Distribution & Maintenance of the Next Generation Green Bins**

Dear Mr. Boily,

Please be advised that the above mentioned RFP for the Manufacture, Distribution & Maintenance of the Next Generation Green Bin, has been cancelled, in accordance with the City of Toronto's Municipal Code, Chapter 195- Purchasing, due to the Total Project Value being greater than the available funding.

A refund in the amount of \$84.75 will be issued either by cheque or E- Deposit directly into your bank account.

Please ensure you pick up your samples **no later than October 21, 2013 at 4pm.** Failure to do so by the specified date will result in your samples being disposed of. They can be picked up at 100 Queen Street West, Toronto, ON. 17th Floor.

In closing we thank you for your continued interest in doing business with the City of Toronto and we invite you to continue to search the City's web page to download future call documents that the City may advertise.

Should you have any further questions, please contact Robert Babin, Supervisor Corporate Purchasing at 416-392-7178.

Yours truly,

Elena Caruso, Manager
Goods and Services
Purchasing and Materials Management Division

APPENDIX E - DETAILED EVALUATION TABLE

EVALUATION CRITERIA	Available Points
STAGE 1 - MANDATORY SUBMISSION REQUIREMENTS	Pass/Fail
Compliance with Mandatory Submission Requirements	Pass/Fail
Compliance with Mandatory Technical Requirements	Pass/Fail
STAGE 2A – TECHNICAL REQUIREMENTS	50
The "Stage 2A-Technical Requirements" has a minimum pass mark of 80% or 40 points. Proponents not achieving the minimum pass mark will not be considered further.	
Work Plan and Deliverables	5
Financial Stability of the Vendor	5
Bin Collection/Dumping Functioning	10
Bin Design/Functionality	15
Effectiveness/Functioning of Raccoon Resistant Latch	15
STAGE 2B – FUNCTIONAL PROTOTYPE REQUIREMENTS	25
To verify and confirm the Bin design and functionality, full scale functioning prototypes will be requested from Proponents that meet the minimum technical score. Proponents must supply a prototype within 4 weeks of request , at no additional cost to the City. Prototype offered must meet the design submitted and evaluated under Appendix E Stage 1 and Stage 2A. New designs replacing those designs originally submitted and evaluated under Appendix E Stage 1 and 2A will not be accepted and Proposal will be rejected.	
Bin Collection/Dumping Functioning	5
Bin Design/Functioning	10
Effectiveness/Functioning of Raccoon Resistant Latch	10
STAGE 3 – COST Proponents must score a minimum of 80% or 60 points (Stage 2A + Stage 2B) to be considered further for costs. Price/Cost: [Formula: (lowest cost Proposal ÷ Proponents's Proposal cost) x 25]	25
TOTAL SCORE	100

CRITERIA FOR EVALUATION SCORING SYSTEM FOR 2A & 2B TECHNICAL REQUIREMENTS

Scale Percentage	Description
0-20 % of Weighted Score	Poor: Minimally addresses the requirements, but one or more major considerations of the requirements are not addressed.
40% of Weighted Score	Fair: The response addresses the requirements adequately, but minor considerations may not be addressed.
60% of Weighted Score	Good: The response fully addresses the requirements and provides a good quality solution. Good degree of confidence in the Proponent's response or proposed solution met.
80% of Weighted Score	Very Good: All considerations of the requirements are addressed with a high degree of confidence in the Proponent's response or proposed solution.
100% of Weighted Score	Excellent: All considerations of the requirements are addressed with the highest degree of confidence in the Proponent's response or proposed solution.

APPENDIX E – PROPOSAL EVALUATION TABLE

EVALUATION CRITERIA	Available Points
STEP 1 - MANDATORY SUBMISSION REQUIREMENTS	Pass/Fail
Compliance with Mandatory Submission Requirements	Pass/Fail
Compliance with Mandatory Technical Requirements	Pass/Fail
STEP 2 – REVIEW WRITTEN PROPOSALS	100
Work Plan and Deliverables	15
Financial Stability of the Vendor	10
Green Bin Collection/Dumping Functioning	25
Green Bin Design/Functionality	25
Effectiveness/Functioning of Raccoon Resistant Latch	25
TOTAL SCORE- MINIMUM 75 PERCENT (75 Points) TO CONTINUE	
STEP 3 REVIEW FUNCTIONAL PROTOTYPES (Scoring starts new and does not carry forward from Step 2)	75
Green Bin Collection/Dumping Functioning	25
Effectiveness/Functioning of Raccoon Resistant Latch	25
Green Bin Design/Functioning	15
Public Consultation Feedback	10
TOTAL SCORE- MINIMUM 75 PERCENT (56 Points) TO CONTINUE	
STEP 4 COST Proponents must score a minimum of 75 percent from Step 3 to be considered further for costs. Price/Cost: [Formula: (lowest cost Proposal ÷ Proponent's Proposal cost) x 25]	25
TOTAL SCORES (Step 3 Score + Step 5)	100

CRITERIA FOR EVALUATION SCORING SYSTEM FOR STEP 2 and STEP 3 REQUIREMENTS

Scale Percentage	Description
0-25% of Weighted Score	Poor: Minimally addresses some, but not all, of the requirements of the criterion. Lacking in critical areas.
50% of Weighted Score	Satisfactory: Adequately meets most of the requirements of the criterion. May be lacking in some areas that are not critical.
75% of Weighted Score	Very Good: Fully meets all requirements of the criterion.
100% of Weighted Score	Excellent: All considerations of the requirements are addressed or exceeded with the highest degree of confidence in the Proponent's response or proposed solution.



Purchasing & Materials Management
Victor Tryl, Acting Director

City Hall
18th Floor, West
100 Queen Street West
Toronto, Ontario M5H 2N2

Elena Caruso, Manager
Goods and Services
Tel: 416-392-7316
ecaruso@toronto.ca

July 29, 2014

IPL Inc.
140 Commercial Street
Saint-Damien-de-Buckland,
Quebec, G0R 2Y0

**SENT VIA EMAIL: sboily@ipl-plastics.com
tjohns@ipl-plastics.com**

Attention: Steve Boily,

**Subject: Request for Proposal (RFP) No. 0401-14-3100
For: The Manufacture, Distribution, & Maintenance of the Next Generation Green
Bin required by the City of Toronto's Solid Waste Management Services division.**

Dear Mr. Boily,

Thank you for your response to the above subject RFP for the Manufacture, Distribution, & Maintenance of the Next Generation Green Bin required by the City of Toronto's Solid Waste Management Services division.

We appreciate the time and effort your firm has invested in this RFP. It is a requirement of the RFP that Proponents must meet a minimum threshold of 75% in order to advance further in the evaluation process. The Evaluation Team has reviewed your proposal and based on the results of the evaluation, your firm has not been short-listed to proceed further in this RFP process.

In closing, we again thank you for your interest in this RFP, and invite you to submit proposals for any future initiatives the City of Toronto may advertise. All firms are entitled to a debriefing (formal or informal), upon written request made to the Chief Purchasing Official, to obtain feedback on why their proposal was not successful.

If you have any questions or wish to schedule a debriefing, please contact Senior Corporate Buyer Ted Justin at (416) 338-5578 or by email at tjustin@toronto.ca.

Yours truly,

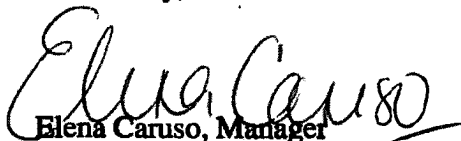
Elena Caruso, Manager
Goods and Services

NOTE CONFIDENTIELLE: L'information transmise par ce courriel est de nature privilégiée et confidentielle. Elle est destinée à l'usage exclusif du destinataire ci-dessus. Si vous n'êtes pas le destinataire visé, vous êtes par la présente avisé qu'il est strictement interdit d'utiliser cette information, de la copier, de la distribuer ou la diffuser. Si cette communication vous a été transmise par erreur, veuillez la détruire et nous en aviser immédiatement

From: Ted Justin [<mailto:tjustin@toronto.ca>]
Sent: August-14-14 8:27 AM
To: Paul Palazzo
Subject: Re: Request for Proposal (RFP) No. 0401-13-4100

Mr. Palazzo

Regrettably, we are unable to accommodate your request for a debrief until the process has been concluded in its entirety; in compliance with the City of Toronto's Purchasing & Materials Management procedural guidelines.

While we understand your interest, our hands are tied.

Once an award has been made the City will gladly share the evaluation team scoring comments with you via a debrief.

Please feel free to stay in touch.

Regards

Ted Justin
Senior Corporate Buyer
City of Toronto
Tel:(416)338-5578

>>> "Paul Palazzo" <ppalazzo@ipl-plastics.com> 14/08/2014 12:13 AM >>>

Mr. Justin,

Further to our phone conversation of July 30th.14 at which time you confirmed IPL did not achieve the minimum 75% threshold and you informed me that a debriefing meeting could only be held until after program award in January 2015, I have been asked by our new CEO, Paul Richardson, for a debriefing meeting later this month; if this is this possible, it would be greatly appreciated.

Sincerely,

Paul Palazzo
Director of Sales
IPL Environmental
c: (905) 866-4758
f: (905) 662-8518
e: ppalazzo@ipl-plastics.com
www.ipl-plastics.com

IPL Environmental....striving to become the reference in Residential Waste Solutions supporting community wellness.

TORONTO MUNICIPAL CODE
CHAPTER 195, PURCHASING

- (2) The goods, services or construction to be provided by the call no longer meet the division's requirements; or
- C. In the opinion of the Chief Purchasing Official the integrity of the call process has been compromised.

§ 195-9. Authority of Chief Purchasing Official to award and enter into commitments.

- A. The Chief Purchasing Official shall be authorized, in consultation with the division head or designate initiating the call, to make an award arising from the issuance of a call and enter into a commitment in respect of the award, provided that the following conditions are met: **[Amended 2005-04-14 by By-law No. 331-2005]**

- (1) The award and commitment are:
 - (a) Within the commitment limit;
 - (b) Within the maximum dollar amount of any commitment authority delegated to staff under the provisions of the Financial Control By-law;⁶ and
 - (c) Have funding approval;
- (2) The award is to the lowest bidder whose bid meets the specifications and requirements set out in the call or to the highest ranked proponent resulting from an evaluation and meeting the requirements of the call, including the evaluation criteria set out in the call; and
- (3) There is no material written objection to the merits of the award filed by a bidder with the Chief Purchasing Official before the award is made.

- B. The Chief Purchasing Official shall be authorized to enter into a commitment without the issuance of a call under the following circumstances:

- (1) When an event occurs that the City Manager, a division head or a delegate determines is a threat to public health, the maintenance of essential City services, the welfare of persons or of public property or the security of the City's interests and the occurrence requires the immediate delivery of goods or services, and time does not permit for an award, other than by the Chief Purchasing Official, but in the case of a delegate's determination, the resulting commitment must be within the commitment authority of the delegate under the Financial Control By-law;⁷ or **[Amended 2005-04-14 by By-law No. 331-2005]**

⁶ Editor's Note: See Ch. 71, Financial Control.

⁷ Editor's Note: See Ch. 71, Financial Control.

TORONTO MUNICIPAL CODE
CHAPTER 195, PURCHASING

- (b) The written confirmation of the Chief Financial Officer that the funding of the commitment can be undertaken to his or her satisfaction.

MATERIAL WRITTEN OBJECTION - A written objection to an award that relates to the exercise of discretion of the Chief Purchasing Official in accepting or rejecting responses as being compliant or non-compliant with a call and which is not:

- A. Frivolous or vexatious in the opinion of the Chief Purchasing Official; or
- B. Solely related to a review of any listed irregularities that any City policy on procurement processes instructs or authorizes the Chief Purchasing Official to automatically reject.

PRE-QUALIFICATION SUBMISSION - The submission of qualifications by a bidder or proponent in response to a call as part of a process to determine those bidders or proponents that would qualify to be solicited in a subsequent call leading to an award.

PROJECT - An undertaking in respect of which an expenditure is incurred to acquire, improve, demolish or maintain land, buildings, engineering structures, machinery and equipment, including installation of computer software, and is the level at which Council approves funding and funds control in the capital budget.

PROPONENT - Any legal entity submitting a proposal, a pre-qualification submission preliminary to a proposal or an expression of interest in response to a call.

PROPOSAL - An offer to furnish goods, services or construction, including professional or consulting services, as a basis for negotiations for entering into a contract.

PUBLIC BODY - Any local board and commission and any non-profit corporation or municipal or government body carrying out a public function and, in addition, any corporation of which the City is a shareholder.

QUOTATION - An offer to buy or supply specified goods or services at a price fixed as to the total amount or on a unit basis, or both.

RESPONSE - The submission of a bid, proposal, expression of interest or pre-qualification submission in response to a call.

SOLICITATION - The process of notifying prospective bidders or proponents that the City wishes to receive offers through a bid or proposal or to receive pre-qualification submissions or expressions of interest.

STANDING COMMITTEE - A standing committee established under Chapter 27, Council Procedures. **[Amended 2005-04-14 by By-law No. 331-2005]**

Fasken Martineau DuMoulin LLP
Barristers and Solicitors
Patent and Trade-mark Agents

www.fasken.com

Suite 800
140 Grande Allée East
Québec, Quebec, Canada G1R 5M8

418 640 2000 Telephone
418 647 2455 Facsimile
1 800 463 2827 Toll free



Claude Girard, direct line (418) 640-2050
email: cgirard@fasken.com

Québec, November 25, 2014

BY EMAIL

WITHOUT PREJUDICE

Mr. Michael Pacholok
Director
Purchasing and Materials Management Division
City of Toronto
City Hall, 18th Floor, West Tower
100 Queen Street West
Toronto, Ontario M5H 2N2

Sir:

Re: Request for Proposal No. 0401-14-3100
Manufacturing, Distribution & Maintenance
if the Next Generation Green Bin / Two-Envelope System
Our file No. 104540.00083

We are acting as counsel to IPL Inc. (“IPL”) in connection with the captioned Request for Proposal (“RFP 2014”).

For and on behalf of IPL, we hereby file a complaint with respect to the RFP 2014 process and assessment based on the grounds referred to below.

In 2013, the City of Toronto launched the Request for Proposal No. 0401-13-3001 for the Manufacture, Distribution & Maintenance of the Next Generation Green Bid / Two-Envelope System (“RFP 2013”).

In response to the RFP 2013, IPL submitted a proposal which made it to the second envelope stage. However, RFP 2013 was cancelled since, as we understand, all proposals were over the contemplated budget.

DM_QUE/104540.00083/1033868.1

As you know, IPL submitted again a proposal with respect to the RFP 2014. Since both RFP 2013 and RFP 2014 are almost identical as to their specifications, IPL was confused upon receiving notification that its proposal did not make it out of the first set of scoring given how well it had scored in 2013.

Even though IPL's proposal was not "*non-compliant*", we understand that the relevant officer(s) of the Purchasing and Materials Management Division ("**Division**") will not meet IPL's representatives in a timely manner to discuss the issues the Division may have had with IPL's proposal. Therefore, a debrief opportunity being not available until 2015, IPL deems incredibly problematic in its understanding of what, if any, material issues or misunderstandings that the Division may have had with IPL's proposal.

Furthering IPL's confusion set forth above was that an exact bin being part of IPL's proposal with respect to RFP 2014 was recently approved and awarded a contract by Peel Region.

IPL looks forward to discussing with you any potential issues with its proposal and the evaluation process at your earliest convenience.

We would appreciate your reply to this letter be copied to Mr. Paul Palazzo, Director of Sales, IPL Environmental (ppalazzo@ipl-plastics.com).

Best regards,

FASKEN MARTINEAU DuMOULIN LLP

per: 

CG/dt

c.c. Mr. Paul Palazzo

From: Ted Justin [mailto:tjustin@toronto.ca]
Sent: January-05-15 3:57 PM
To: Paul Palazzo
Cc: Chin, Edward (Purchasing); Morgan, Mary Ann
Subject: RE: Request for Proposal (RFP) No. 0401-13-4100

Mr. Palazzo

I think you meant to reference RFP 0401-14-3100.

Once I have confirmed with City staff their availability, I will advise.

regards

Ted Justin

>>> "Paul Palazzo" <ppalazzo@ipl-plastics.com> January 5,2015 1:57 PM >>>

Mr. Justin,

I left you a VM a few minutes ago asking for a debriefing meeting for the RFP No. 0401-13-4100. My request comes after correspondences with Mr. Michael Pacholok; he asked that I contact you for the meeting. Please let me know when we could have the debriefing, as we would like to have it as soon as possible this month , so that we may contemplate our next steps on an informed basis.

Regards,

Paul Palazzo

Director of Sales

IPL Environmental

c: (905) 866-4758

f: (905) 662-8518

e: ppalazzo@ipl-plastics.com

www.ipl-plastics.com

IPL Environmental....striving to become the reference in Residential Waste Solutions supporting community wellness.



Better products in plastic



Before printing think about your commitment with the Environment!

CONFIDENTIALITY NOTE: This message contains information which may be privileged or confidential, or exempt from disclosure under applicable law. If the reader of this message is not the intended recipient, you are hereby NOTIFIED that any dissemination, distribution, retention, archiving, or copying of this communication is strictly prohibited. If you have received this e-mail in error, please notify us immediately.

From: Ted Justin <tjustin@toronto.ca>
Sent: January-13-15 7:46 AM
To: Paul Palazzo
Subject: RE: Request for Proposal (RFP) No. 0401-13-4100

Not yet, my people have been absent. I will get back to you later this week.

Ted Justin
Senior Corporate Buyer
City of Toronto
Tel:(416)338-5578
>>> "Paul Palazzo" <ppalazzo@ipl-plastics.com> January 12,2015 4:19 PM >>>

Ted,
Were you able to establish some meeting dates and times with your colleagues for our debriefing meeting?

Regards,

Paul Palazzo
Director of Sales
IPL Environmental
c: (905) 866-4758
f: (905) 662-8518
e: ppalazzo@ipl-plastics.com
www.ipl-plastics.com

IPL Environmental....striving to become the reference in Residential Waste Solutions supporting community wellness.



Better products in plastic



Before printing think about your commitment with the Environment!

CONFIDENTIALITY NOTE: This message contains information which may be privileged or confidential, or exempt from disclosure under applicable law. If the reader of this message is not the intended recipient, you are hereby NOTIFIED that any dissemination, distribution, retention, archiving, or copying of this communication is strictly prohibited. If you have received this e-mail in error, please notify us immediately.

NOTE CONFIDENTIELLE: L'information transmise par ce courriel est de nature privilégiée et confidentielle. Elle est destinée à l'usage exclusif du destinataire ci-dessus. Si vous n'êtes pas le destinataire visé, vous êtes par la présente avisé qu'il est strictement interdit d'utiliser cette information, de la copier, de la distribuer ou la diffuser. Si cette communication vous a été transmise par erreur, veuillez la détruire et nous en aviser immédiatement

From: Ted Justin <tjustin@toronto.ca>
Sent: January-14-15 9:42 AM
To: Paul Palazzo
Subject: Request for Debrief on RFP 0401-14-3100 Next Generation Green Bin

Mr. Palazzo

City Staff are available for the above debriefing Session on:

Wednesday January 28, 2015, 1:00 pm local time

City Hall
100 Queen St. West
Toronto
Purchasing & Materials Management
17th Floor West tower

Please confirm your availability and who will be attending.

regards

Ted Justin
Senior Corporate Buyer
City of Toronto
Tel:(416)338-5578