



ARCHITECTURAL DRAWINGS

- A100 Context Plan
- A101 Statistics
- A102 Site Plan
- A103A P1 Site Plan Demo
- A103B P1 Parking Plan
- A104 Parking Demo
- A105 P2 Parking Plan

- A201 Ground Floor Plan
- A202 Second to 5th Floor Plans
- A203 6th - 20th Floor Plans
- A204 21st - 22nd / Mech Penthouse

- A400 West Elevations
- A401 East Elevations
- A402 North Elevations
- A403 South Elevations

- A411 South North Building Sections

- A420 3D Views
- A421 3D Views
- A422 3D Views

580 THE EAST MALL

ETOBICOKE

Without Prejudice
February 09, 2023

PROJECT NUMBER: 07816.001

PREVIOUS VS PROPOSED STATISTICS COMPARISON

WITHOUT PREJUDICE

	Previous / Submitted	Proposed
Storey	26 storey	22 storey
Unit Count	253	232
GFA	19,638 sm	18,911 sm
Levels of podium	3 levels	5 levels
North Setback to Park	11.0m	5.0m

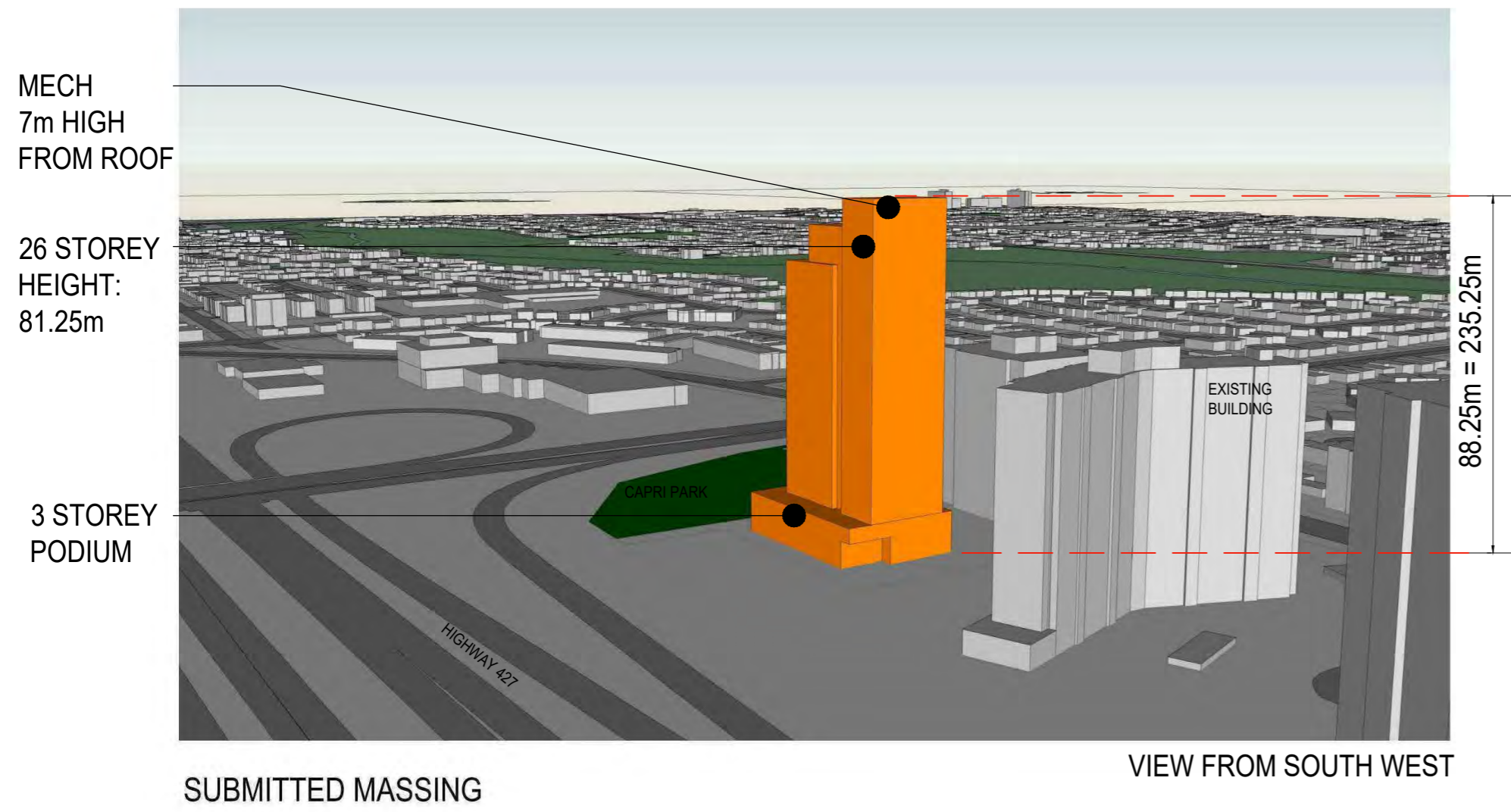

ESTABLISHED GRADE = 000 = 147.00 BASED ON NAV CAN FLIGHT PATH - MAX BUILDING HEIGHT ALLOWED = 219.46m

PRELIMINARY

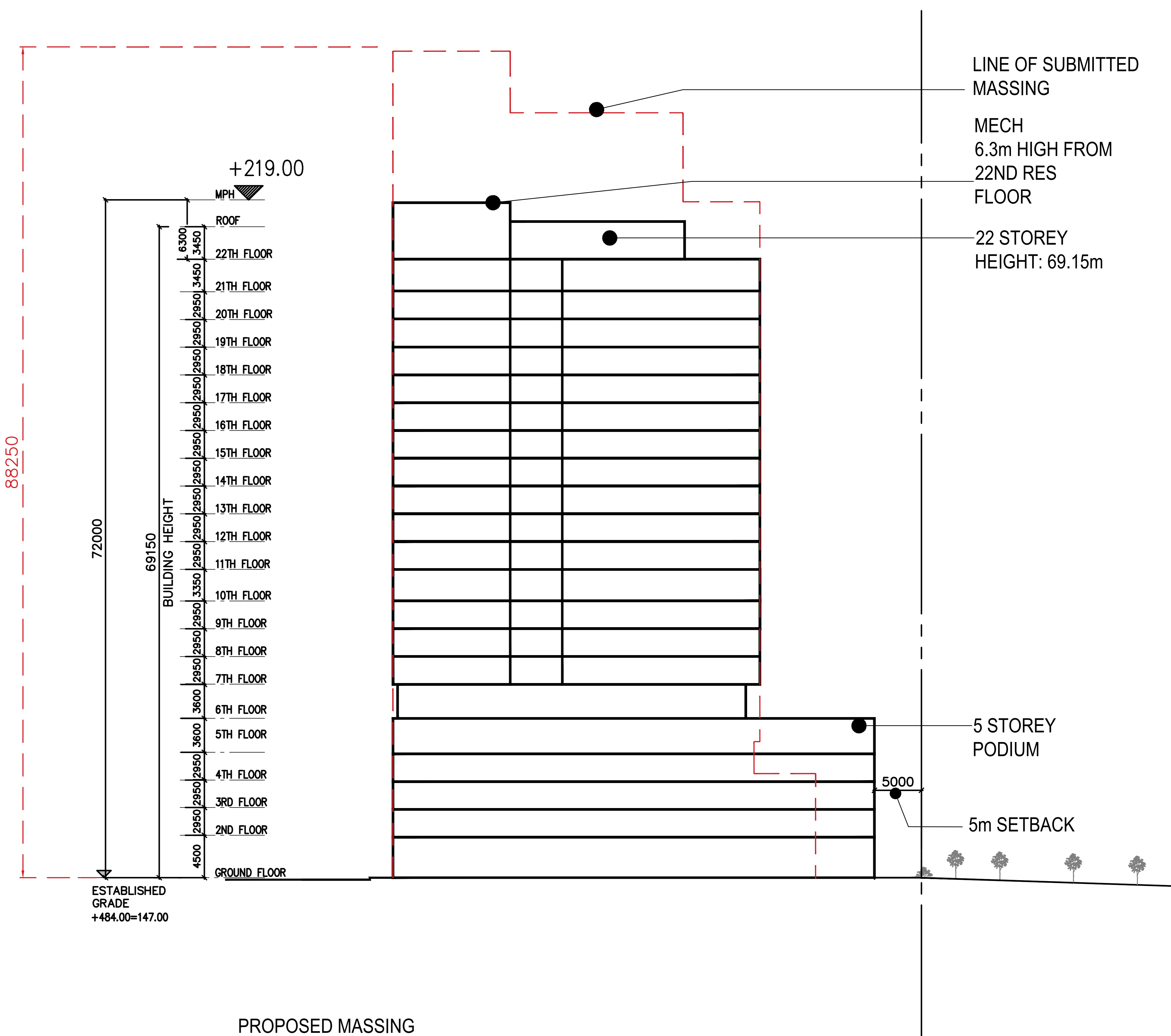
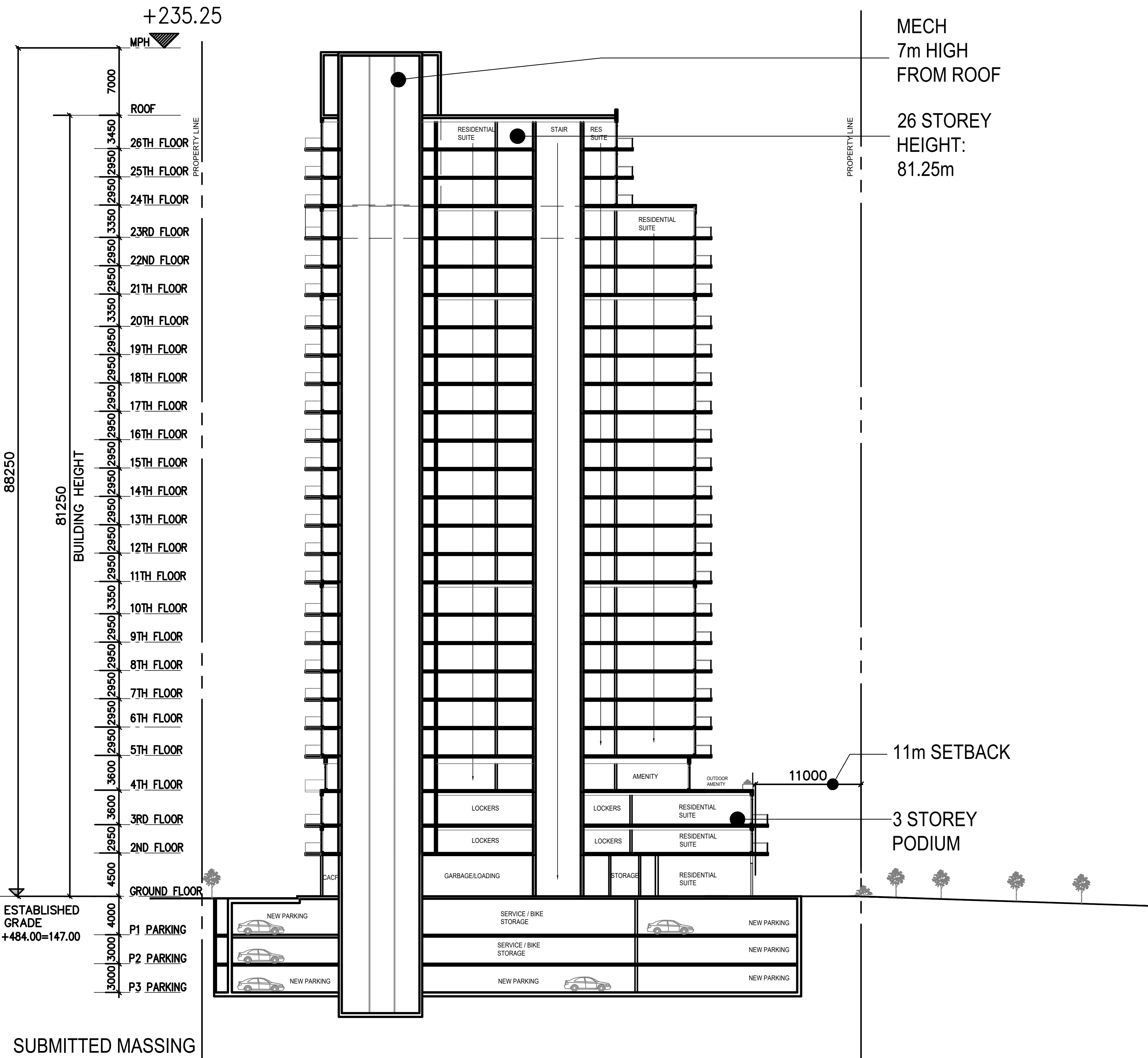

ESTABLISHED GRADE = 000 = 147.00 BASED ON NAV CAN FLIGHT PATH - MAX BUILDING HEIGHT ALLOWED = 219.46m

PRELIMINARY

Project No: 07816	Date
SCALE --	Page Number

Plot Time: Feb 09, 2023 - 7:00pm
 Drawing Name: \\wzmh\Projects\7816\7816_002\6_Drawings\10_Drawings\Design (SD-30)\A-100-CONTEXT PLAN.dwg

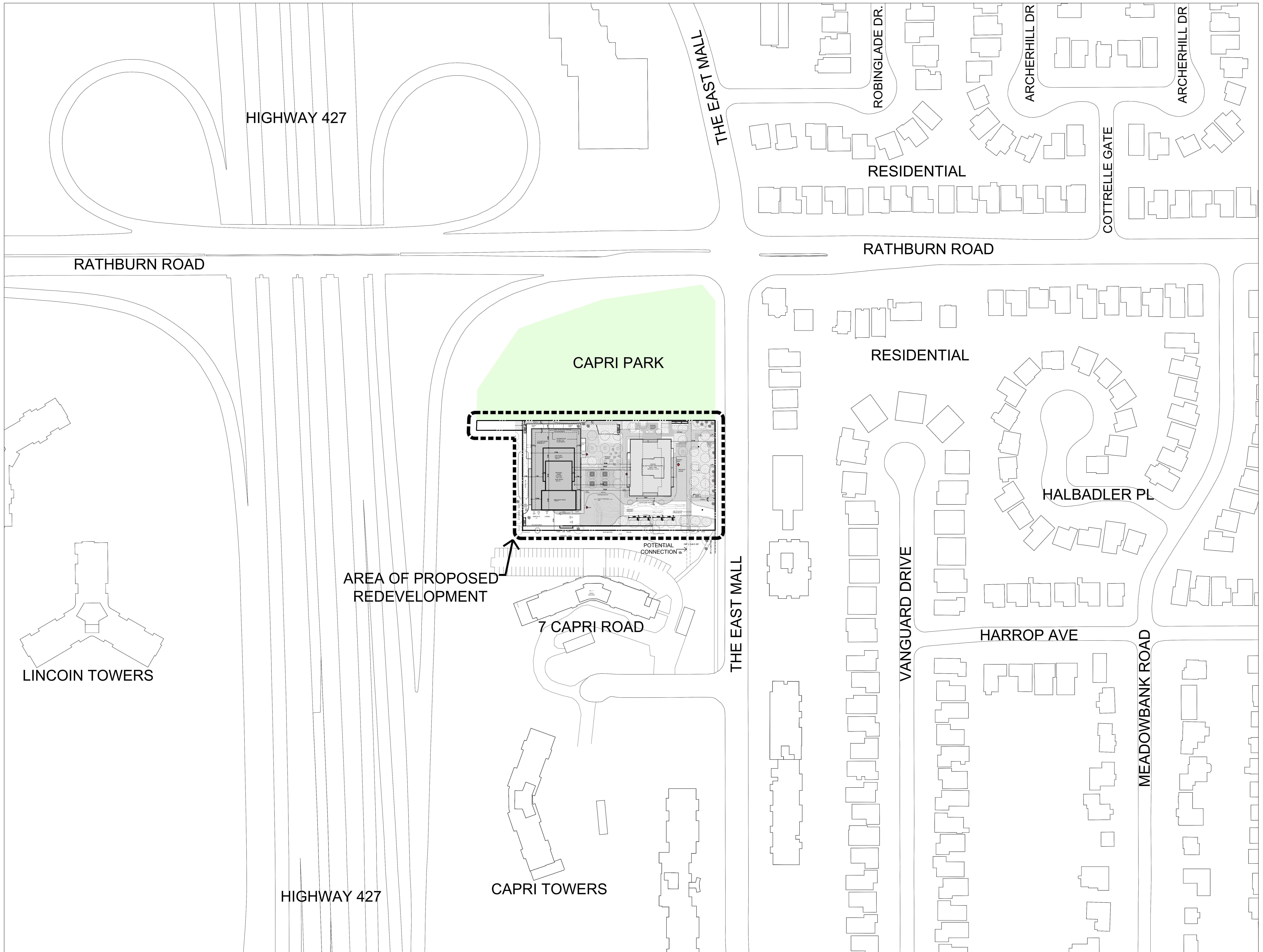

AREA OF PROPOSED REDEVELOPMENT

CAPRI PARK

7 CAPRI ROAD

LINCOLN TOWERS

HIGHWAY 427

CAPRI TOWERS

1 CONTEXT PLAN

A100

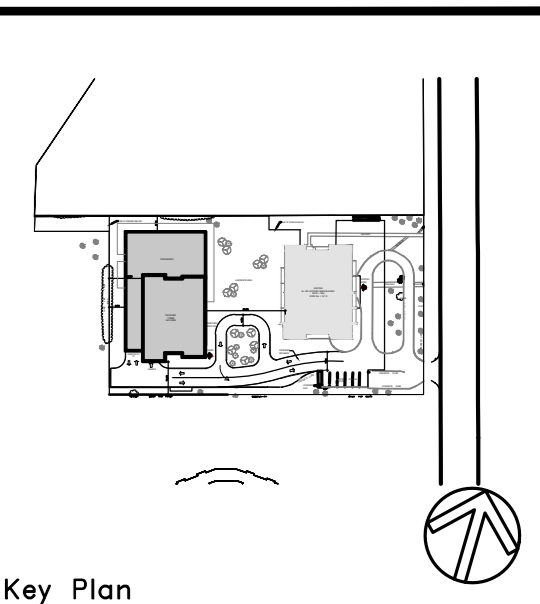

Key Plan

Item	Description	Date
ISSUES/REVISIONS		

WITHOUT PREJUDICE

WITHOUT PREJUDICE	2023/FEB/09
ISSUED FOR REZONING APPLICATION	2021/AUG/30
ISSUED FOR PRE-APPLICATION MEETING	2021/MAY/31
PRELIMINARY SET - ISSUE TO CLIENT	2021/JAN/27

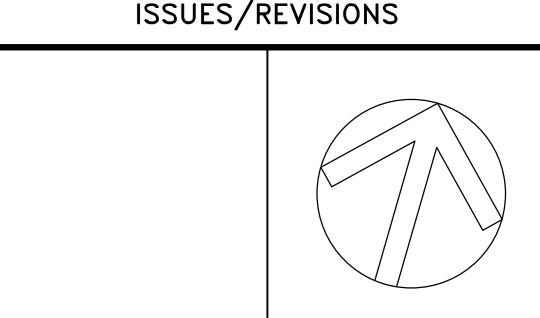

Check and verify all dimensions and report any discrepancies to the Consultant whose seal is affixed to this drawing. This drawing is not to be used for the purpose of setting out.

This drawing shall not be used for construction purposes until signed and sealed in the space below by the above mentioned Consultant.

Issued For Construction _____ Date _____

WZMH ARCHITECTS
 95 St. Clair Av. W
 Suite 100
 Toronto, Ontario
 Canada M5V 1W4
 T 416.961.8174
 F 416.961.8176

GF 580 THE EAST MALL LTD
 TORONTO, ONTARIO

Sheet Title:
CONTEXT PLAN

Scale: 1:750
 Project Number: 07816.000

Drawing Number: A-100

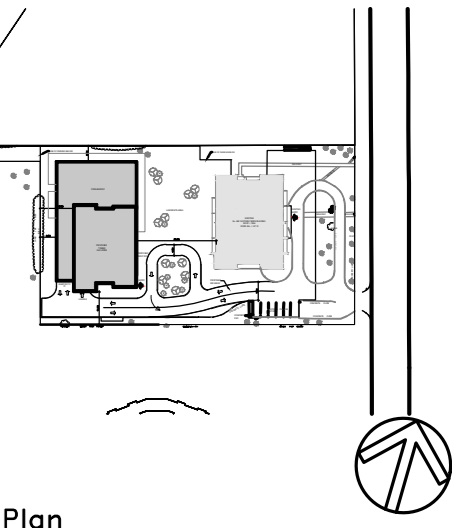

Key Plan



WITHOUT PREJUDICE

Item	Description	Date
WITHOUT PREJUDICE		2023/FEB/09
REISSUED FOR WITHOUT PREJUDICE MEETING		2023/NOV/16
A	ISSUED FOR REZONING APPLICATION	2021/AUL/30
	ISSUED FOR PROGRESS SET	2021/MAY/31
	ISSUED FOR PRE-APPLICATION MEETING	2021/JAN/27
	PRELIMINARY SET - ISSUE TO CLIENT	2021/JAN/08

ISSUES/REVISIONS

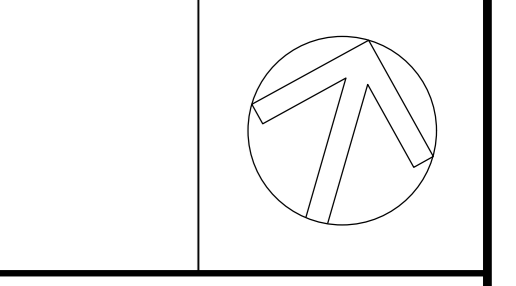

Check and verify all dimensions and report any discrepancies to the Consultant whose seal is affixed to this drawing. This drawing is not to be used for the purpose of setting out.

This drawing shall not be used for construction purposes until signed and sealed in the space below by the above mentioned Consultant.

Issued For Construction: _____ Date: _____

WZMH ARCHITECTS
 95 St. Clair Av. W
 Suite 1500
 Toronto, Ontario
 Canada M5V 1W4
 T 416.961.8114
 F 416.961.8116

GF 580 THE EAST MALL LTD
 TORONTO, ONTARIO

Sheet Title:
SITE PLAN

Scale: 1:200
 Project Number: 07816.000
 Drawing Number: A-102

Plot Time: Feb 08, 2023 - 3:26pm
 Drawing Name: \\wzmb\Projects\7816\7816.002\6_Drawings-Design (SD-30)\A-102-SITE PLAN.dwg

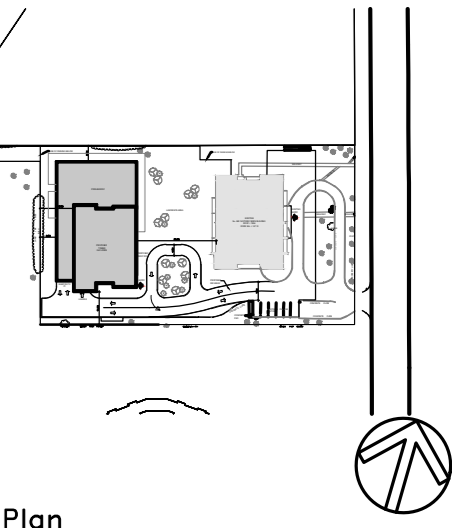

Key Plan

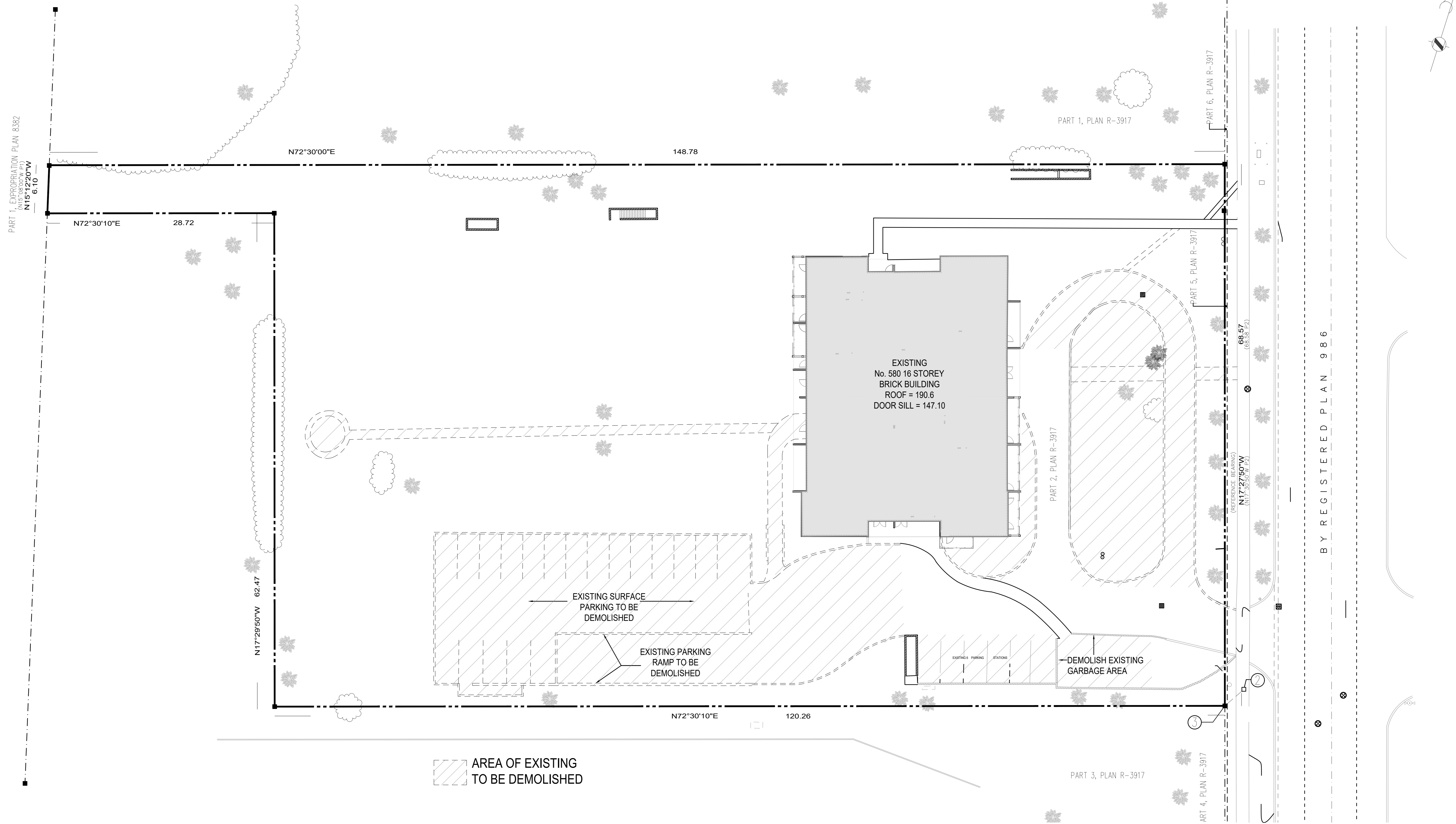

AREA OF EXISTING TO BE DEMOLISHED

BY REGISTERED PLAN 986

ESTABLISHED GRADE ±000 = 147.0

WITHOUT PREJUDICE

WITHOUT PREJUDICE	2023FEB09
ISSUED FOR WITHOUT PREJUDICE MEETING	2023NOV16
A ISSUED FOR REZONING APPLICATION	2021AUG30
ISSUED FOR PROGRESS SET	2021MAY31
ISSUED FOR PRE-APPLICATION MEETING	2021JAN27
PRELIMINARY SET - ISSUE TO CLIENT	2021JAN08

ISSUES/REVISIONS

Item	Description	Date

Check and verify all dimensions and report any discrepancies to the Consultant whose seal is affixed to this drawing. This drawing is not to be used for the purpose of setting out. This drawing shall not be used for construction purposes until signed and sealed in the space below by the above mentioned Consultant.

Issued For Construction: _____ Date: _____

WZMH ARCHITECTS
95 St. Clair Av. W
Suite 1500
Toronto, Ontario
Canada M5V 1W4
T 416.961.4111
F 416.961.4114

GF 580 THE EAST MALL LTD
TORONTO, ONTARIO

Sheet Title:
SITE PLAN DEMO

Scale: 1:200
Project Number: 07816.000
Drawing Number: A-103A

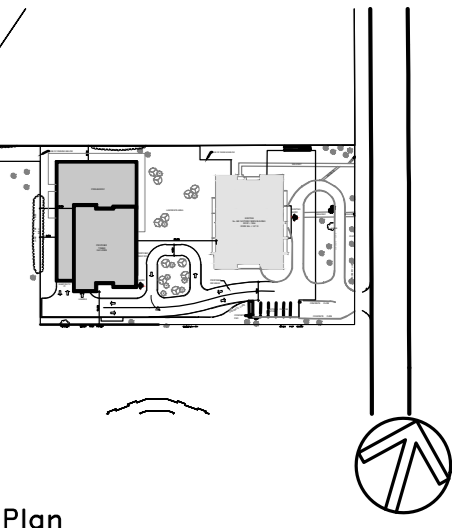

Key Plan

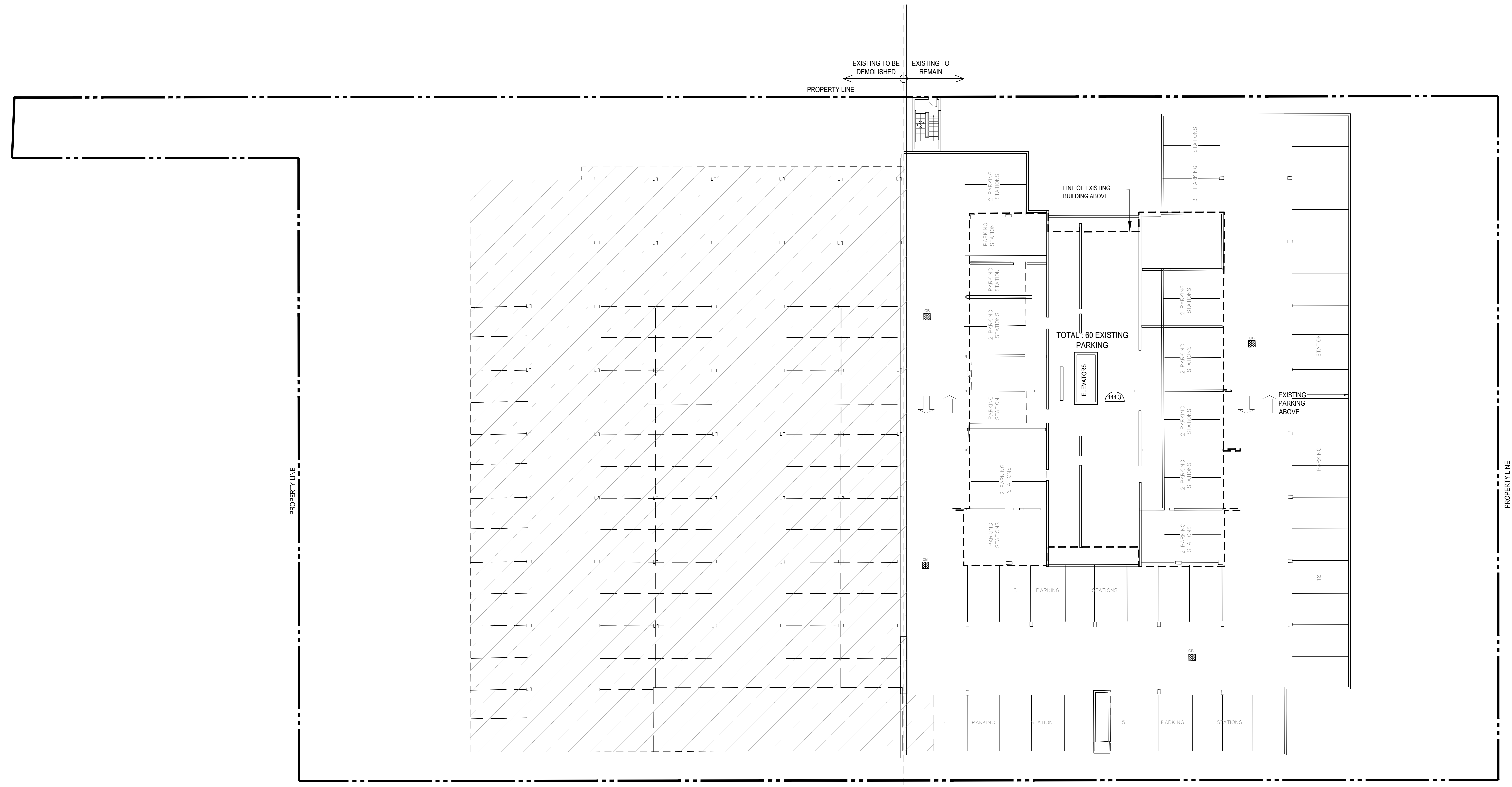

AREA OF EXISTING TO BE DEMOLISHED

WITHOUT PREJUDICE

WITHOUT PREJUDICE	2023/FEB/09
ISSUED FOR PRELIMINARY MEETING	2021/NOV/16
ISSUED FOR REZONING APPLICATION	2021/JUL/30
ISSUED FOR PROGRESS SET	2021/MAY/31
ISSUED FOR PRE-APPLICATION MEETING	2021/JAN/27
PRELIMINARY SET - ISSUE TO CLIENT	2021/JAN/08

ISSUES/REVISIONS

Item	Description	Date

Check and verify all dimensions and report any discrepancies to the Consultant whose seal is affixed to this drawing. This drawing is not to be used for the purpose of setting out.

This drawing shall not be used for construction purposes until signed and sealed in the space below by the above mentioned Consultant.

Issued For Construction: _____ Date: _____

WZMH ARCHITECTS
 95 St. Clair Av. W
 Suite 1500
 Toronto, Ontario
 Canada M5V 1W4
 T 416.941.4114
 F 416.941.8174

GF 580 THE EAST MALL LTD
TORONTO, ONTARIO

Sheet Title:
EXISTING P1 PARKING
DEMO PLAN

Scale: 1:150
 Project Number: 07816.000
 Drawing Number: A-103B

Plot Time: Nov 15, 2022 - 2:35pm
Drawing Name: \\wzmh\Projects\7816\7816.002\6_Drawings-Design (SD-30)\A-103B PARKING DEMO.dwg

1 PARKING P1 (85 PROPOSED + 60 EXISTING) = 145 SPACES

ESTABLISHED GRADE ±000 = 147.0

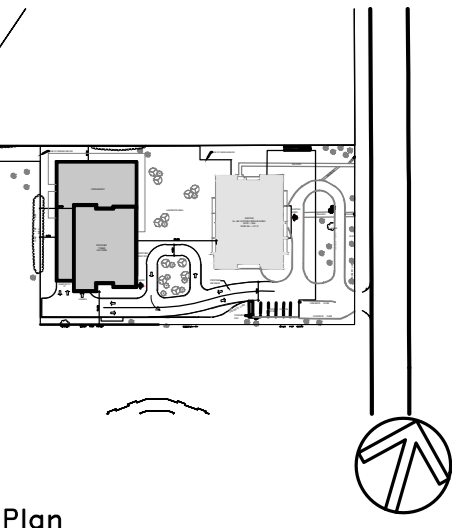

Key Plan

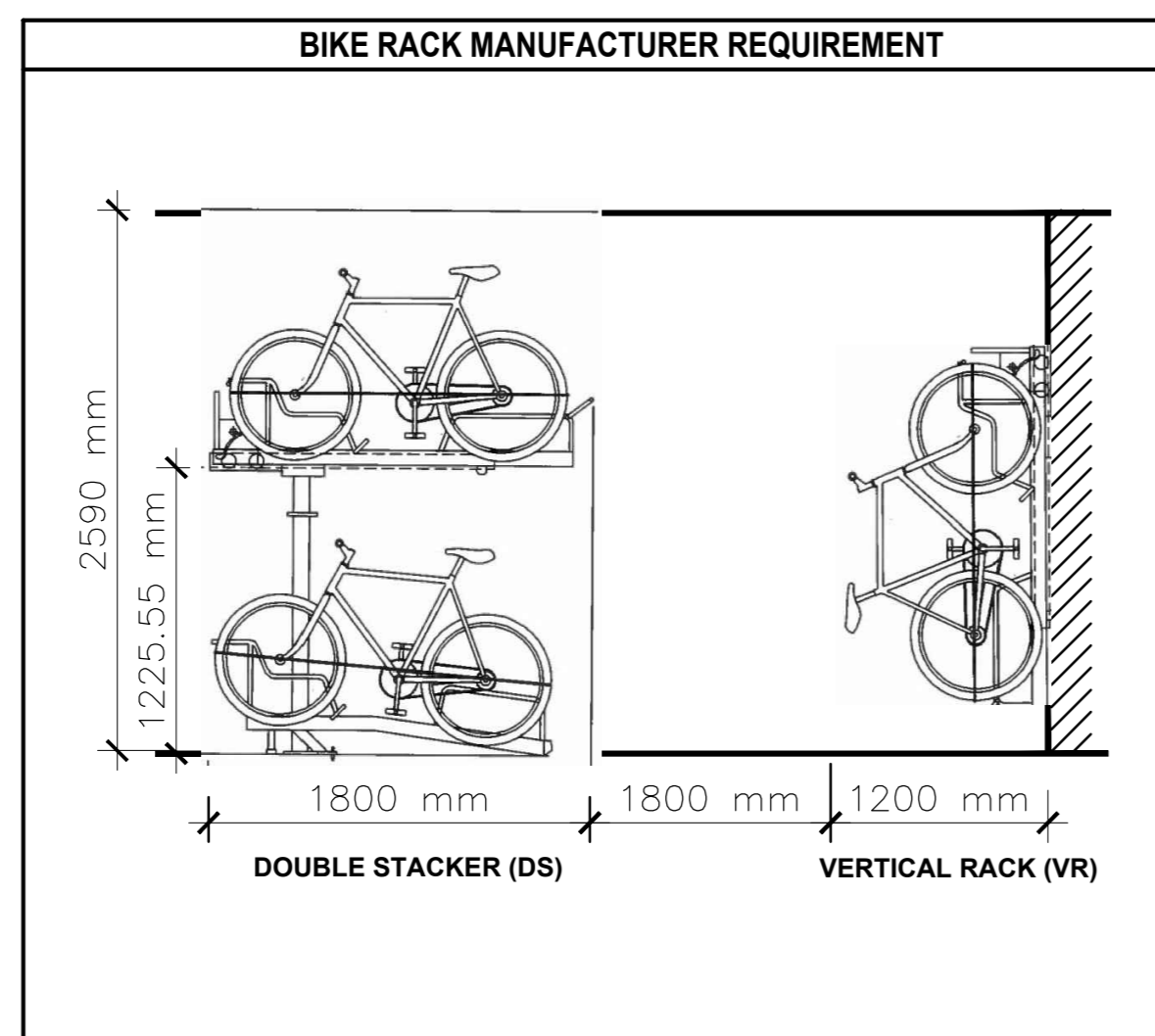
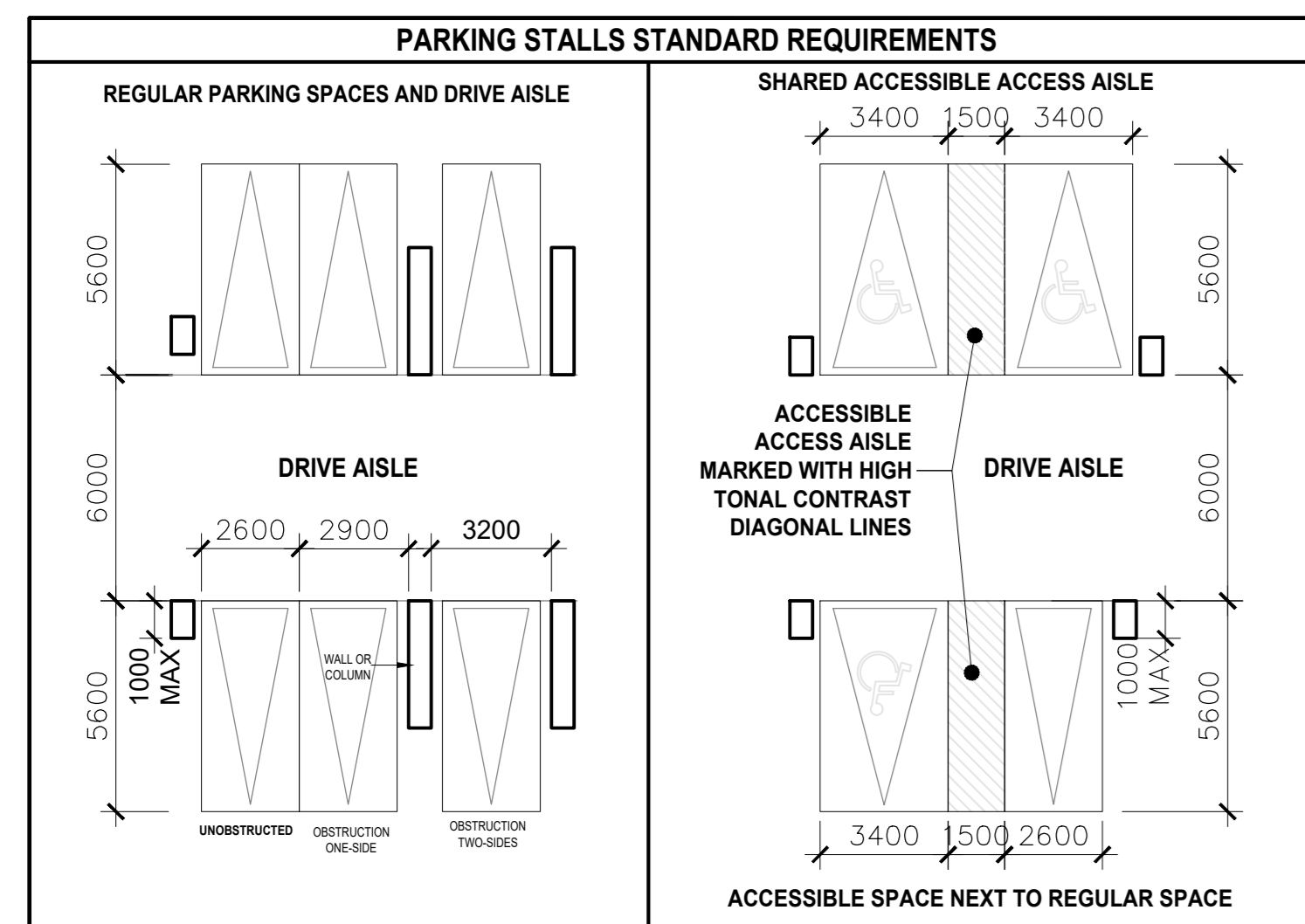
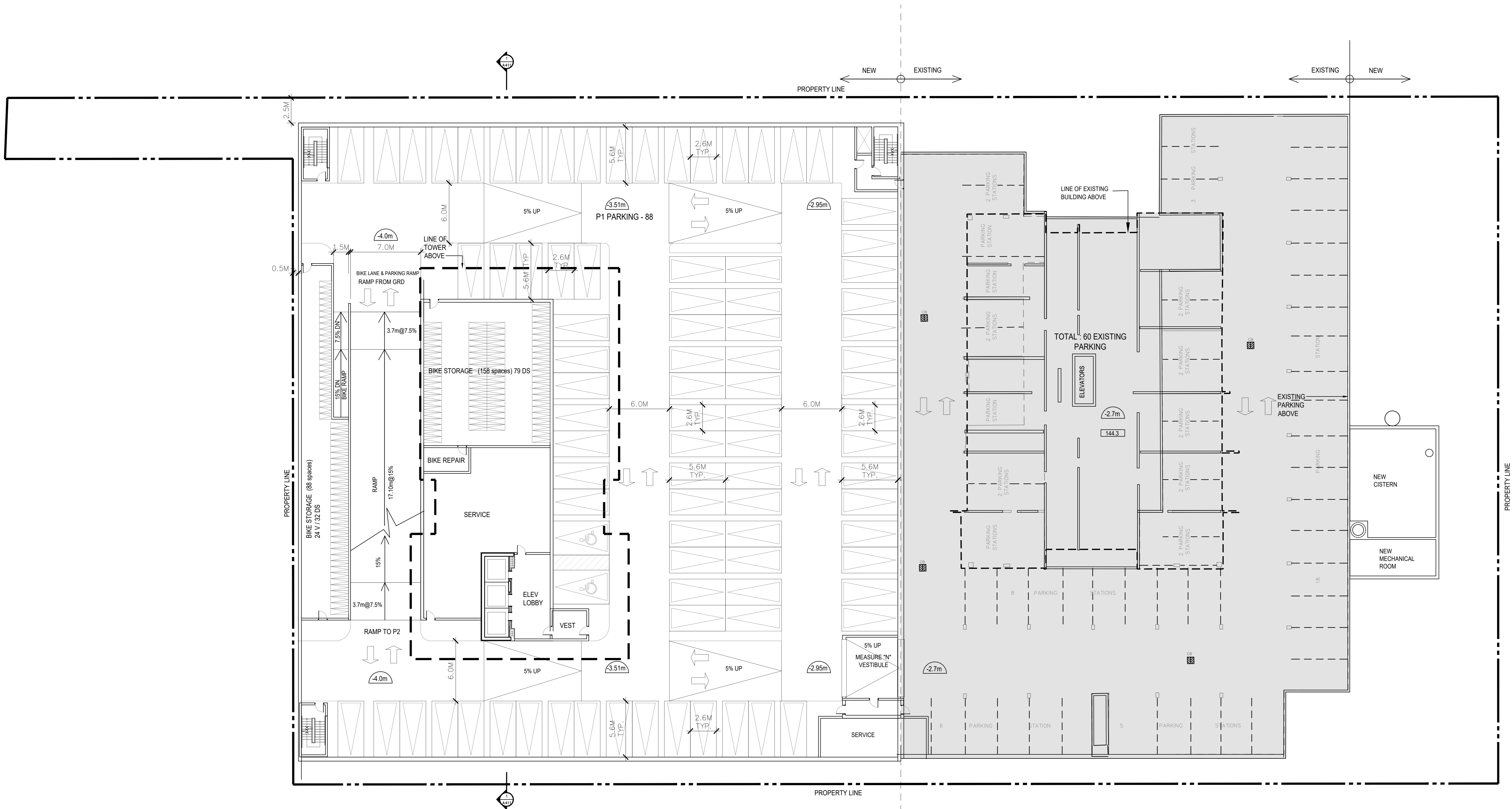

1 PARKING P1 (88 PROPOSED + 60 EXISTING) = 148 SPACES

A104

WITHOUT PREJUDICE

Item	Description	Date
	WITHOUT PREJUDICE	2023/FEB/09
	REISSUED FOR WITHOUT PREJUDICE MEETING	2023/NOV/16
A	ISSUED FOR REZONING APPLICATION	2021/AUL/30
	ISSUED FOR PROGRESS SET	2021/MAY/31
	ISSUED FOR PRE-APPLICATION MEETING	2021/JAN/27
	PRELIMINARY SET - ISSUE TO CLIENT	2021/JAN/08

ISSUES/REVISIONS

Check and verify all dimensions and report any discrepancies to the Consultant whose seal is affixed to this drawing. This drawing is not to be used for the purpose of setting out. This drawing shall not be used for construction purposes until signed and sealed in the space below by the above mentioned Consultant.

Issued For Construction: _____ Date: _____

WZMH ARCHITECTS
 95 St. Clair Av. W
 Suite 1500
 Toronto, Ontario
 Canada M5V 1W4
 T 416.961.8176
 F 416.961.8176

GF 580 THE EAST MALL LTD
 TORONTO, ONTARIO

Sheet Title:
P1 PARKING

Scale: 1:150
 Project Number: 07816.000
 Drawing Number: A-104

ESTABLISHED GRADE ±000 = 147.0

Plot Time: Jan 10, 2023 - 11:44am
 Drawing Name: \\wzmm\Projects\7816\7816.002\6_Drawings-Design (SD-00)\A-104_P1_PARKING.dwg

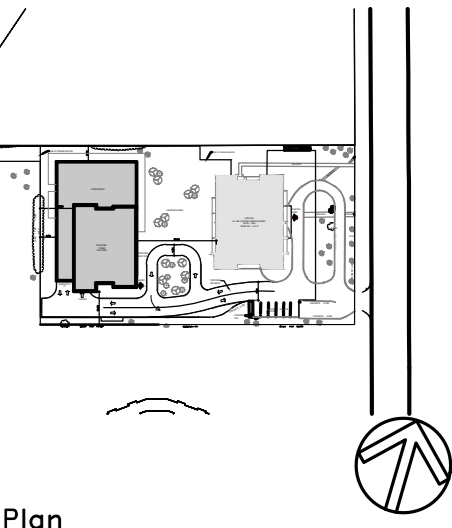

Key Plan

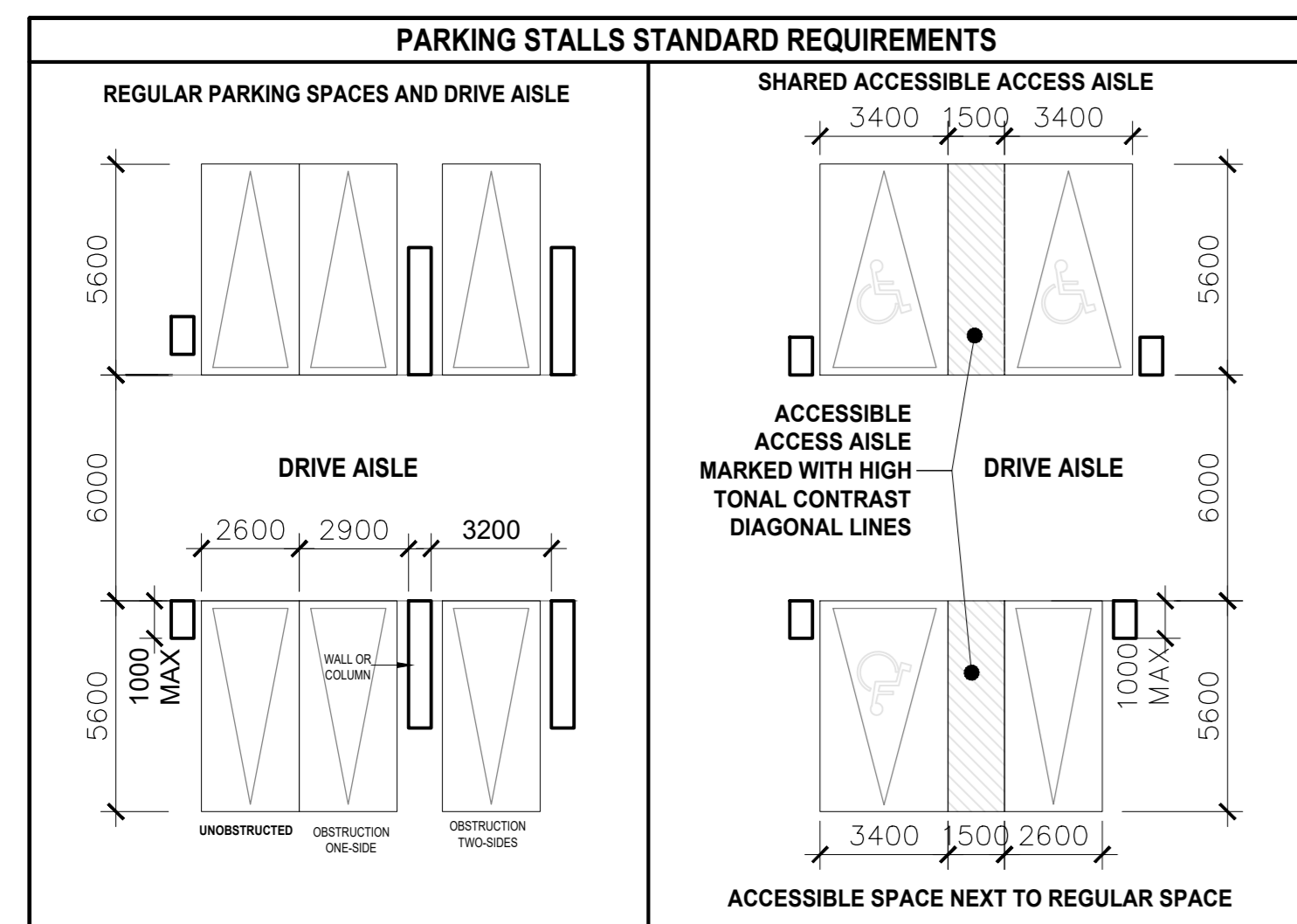
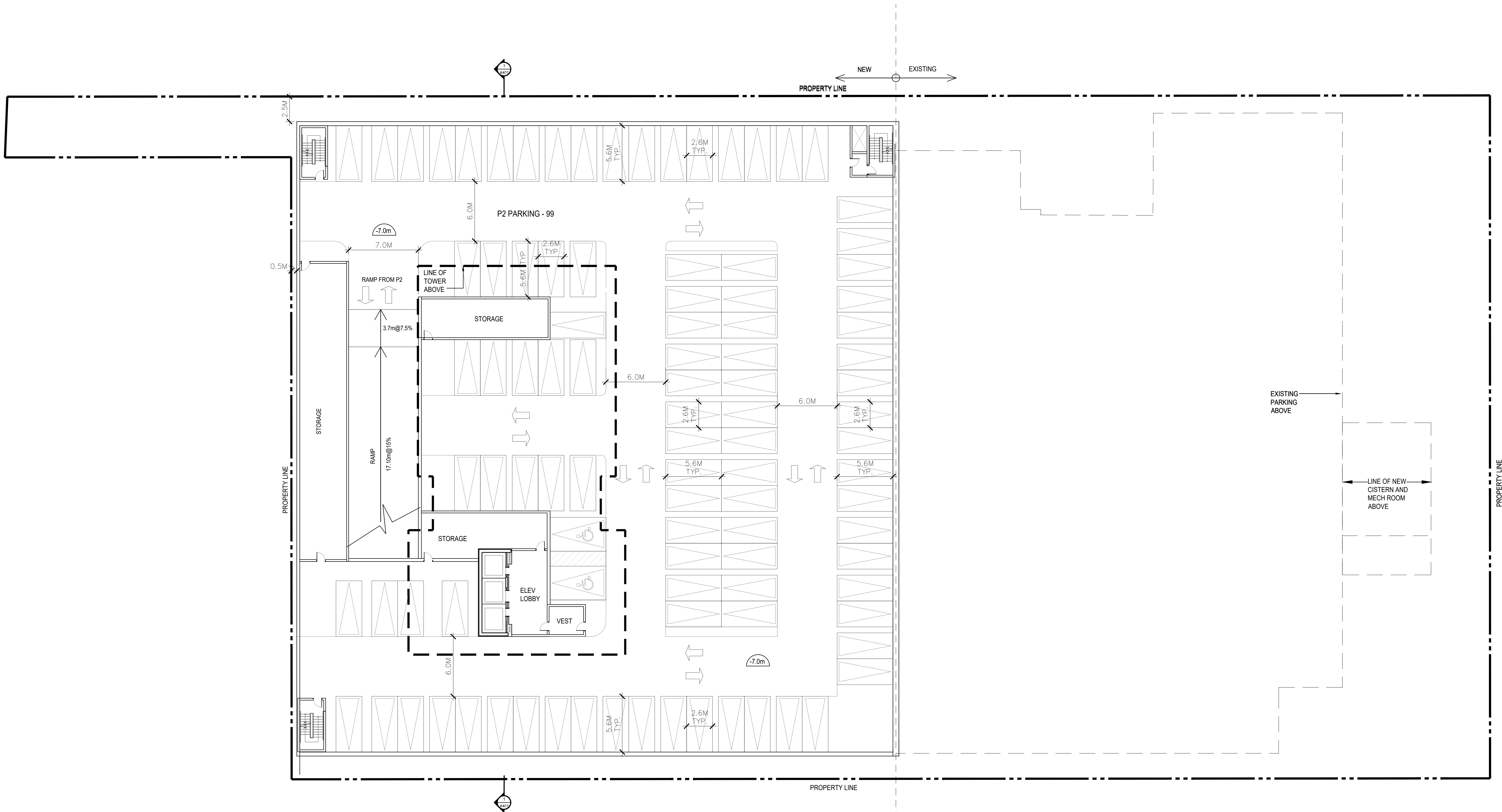

1 PARKING P2 - 99 PROPOSED SPACES

ESTABLISHED GRADE ±000 = 147.0

WITHOUT PREJUDICE

WITHOUT PREJUDICE	2023/FEB/09
ISSUED FOR PRELIMINARY MEETING	2021/NOV/16
A ISSUED FOR REZONING APPLICATION	2021/JUL/30
ISSUED FOR PROGRESS SET	2021/MAY/31
ISSUED FOR PRE-APPLICATION MEETING	2021/JAN/27
PRELIMINARY SET - ISSUE TO CLIENT	2021/JAN/08

ISSUES/REVISIONS

Item	Description	Date

Check and verify all dimensions and report any discrepancies to the Consultant whose seal is affixed to this drawing. This drawing is not to be used for the purpose of setting out.

Issued For Construction: _____ Date: _____

WZMH ARCHITECTS
 95 St. Clair Av. W
 Suite 1500
 Toronto, Ontario
 Canada M5V 1W4
 T 416.941.4114
 F 416.941.4114

GF 580 THE EAST MALL LTD
 TORONTO, ONTARIO

Sheet Title:
P2 PARKING

Scale: 1:150
 Project Number: 07816.000
 Drawing Number: A-105

Plot Time: Jan 10, 2023 - 11:43am
 Drawing Name: \\wzmb\Projects\7816\7816_002\6_Drawings-Design (SD-00)\A-105_P2_PARKING.dwg

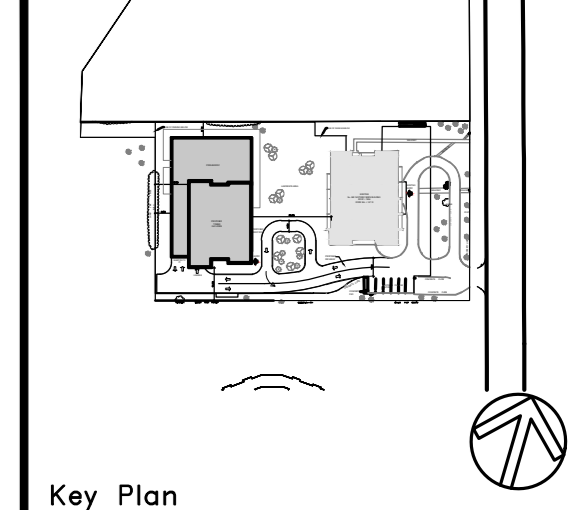
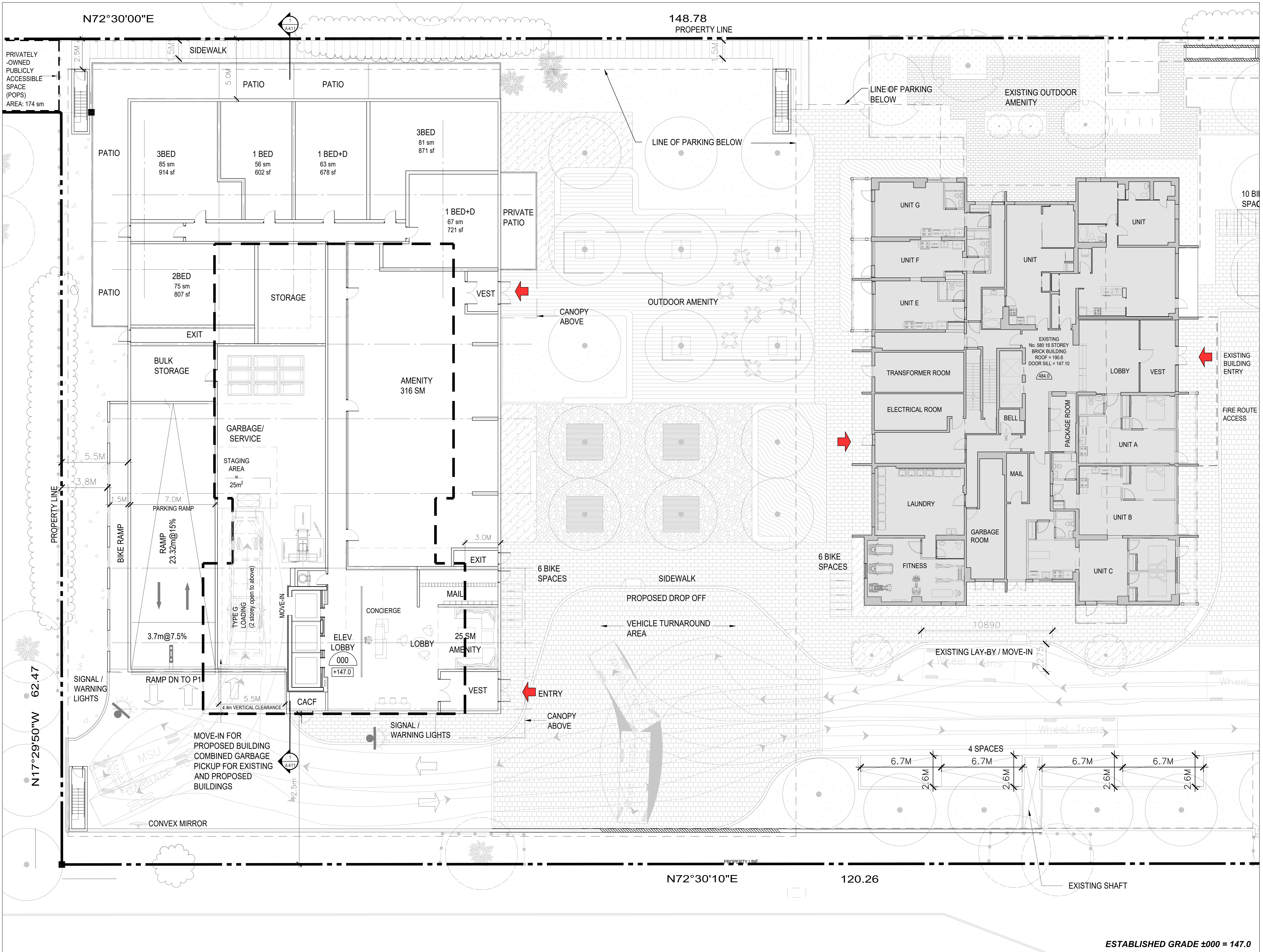

Item	Description	Date
WITHOUT PREJUDICE	2023/FEB/09	
ISSUED FOR PRELIMINARY MEETING	2023/NOV/16	
ISSUED FOR REZONING APPLICATION	2021/JUL/30	
ISSUED FOR PROGRESS SET	2021/MAY/31	
ISSUED FOR PRE-APPLICATION MEETING	2021/JAN/27	
PRELIMINARY SET - ISSUE TO CLIENT	2021/JAN/08	

Item	Description	Date
ISSUES/REVISIONS		

Check and verify all dimensions and report any discrepancies to the Consultant whose seal is affixed to this drawing. This drawing is not to be used for the purpose of setting out. This drawing shall not be used for construction purposes until signed and sealed in the space below by the above mentioned Consultant.

Issued For Construction: _____ Date: _____

WZMH ARCHITECTS
 95 St. Clair Av. W
 Suite 1500
 Toronto, Ontario
 Canada M5V 1W4
 T 416.941.4114
 F 416.941.4114

GF 580 THE EAST MALL LTD
 TORONTO, ONTARIO

Sheet Title:
GROUND FLOOR PLAN

Scale: 1:100
 Project Number: 07816.000
 Drawing Number: A-201

1 GROUND FLOOR PLAN

ESTABLISHED GRADE ±000 = 147.0

Plot Time: Feb 08, 2023 - 3:27pm
 Drawing Name: \\wzmm\Projects\17816\17816.002\6_Drawings\10_Drawings-Design (SD-30)\A-201_GROUND FLOOR.dwg
 A201

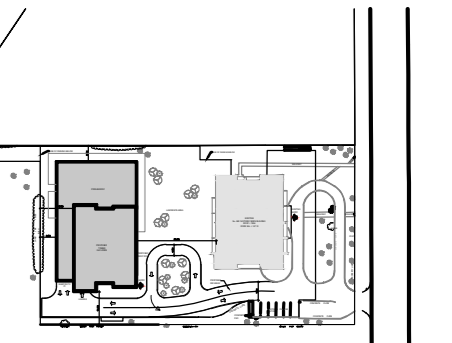

Key Plan

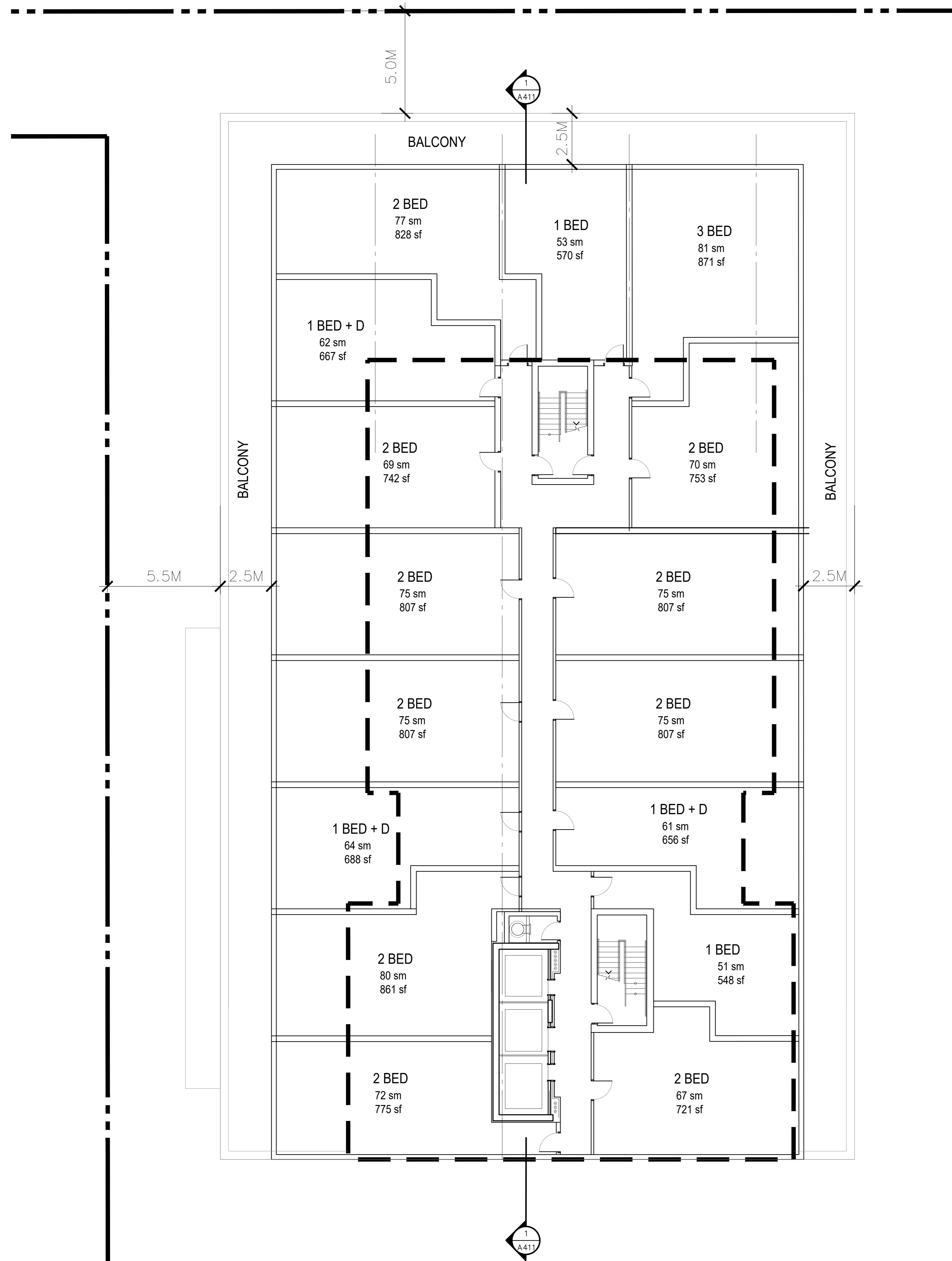

2 PODIUM FLOOR PLAN (3RD-5TH)

A202

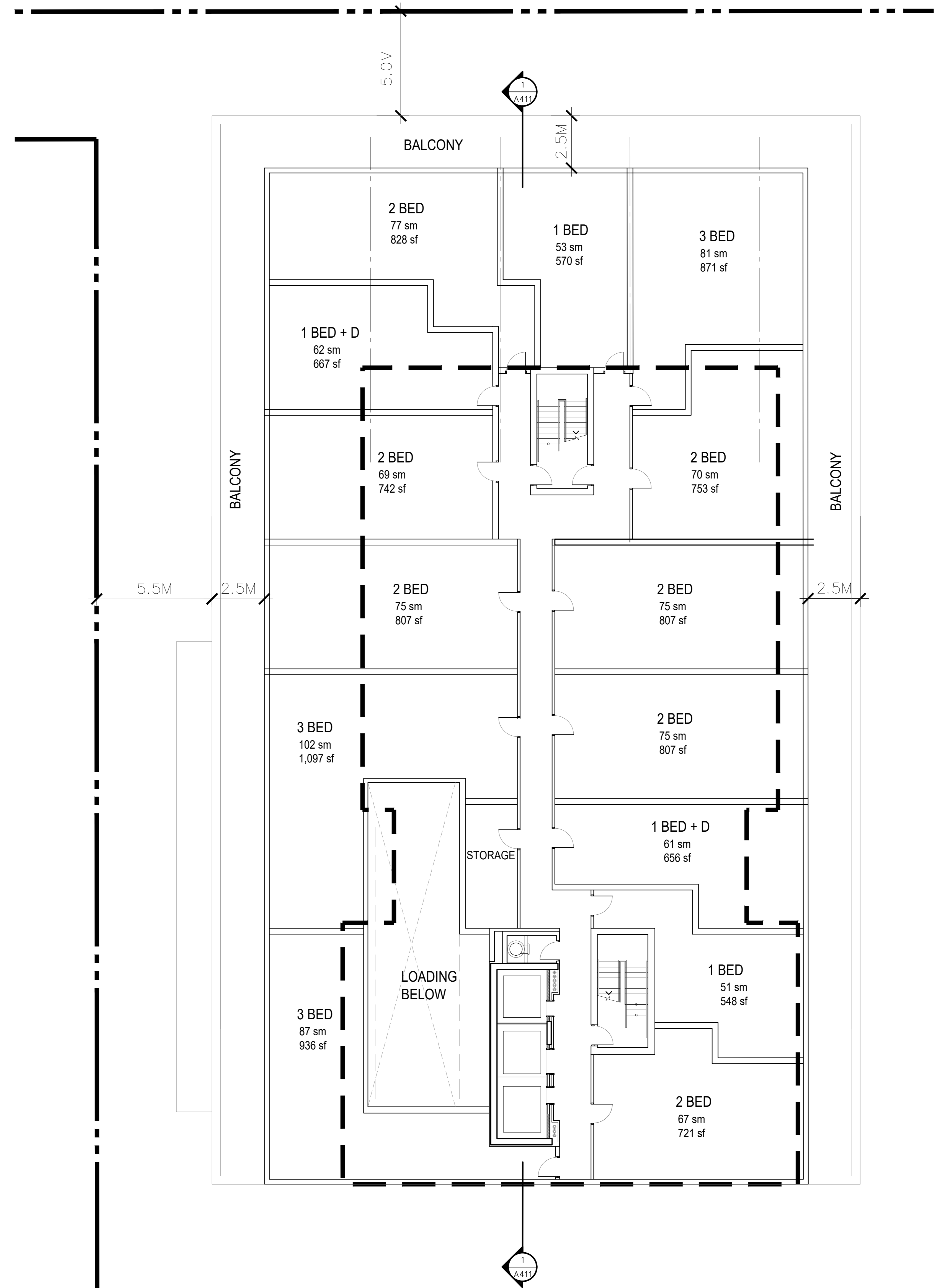

1 PODIUM FLOOR PLAN (2ND)

A202

WITHOUT PREJUDICE

WITHOUT PREJUDICE	2023FEB09
REVISED FOR WITHOUT PREJUDICE MEETING	2023NOV16
A ISSUED FOR REZONING APPLICATION	2021JUL30
ISSUED FOR PROGRESS SET	2021MAY31
ISSUED FOR PRE-APPLICATION MEETING	2021JAN27
PRELIMINARY SET - ISSUE TO CLIENT	2021JAN08

ISSUES/REVISIONS

Item	Description	Date

Check and verify all dimensions and report any discrepancies to the Consultant whose seal is affixed to this drawing. This drawing is not to be used for the purpose of setting out.

Issued For Construction: _____ Date: _____

WZMH ARCHITECTS

95 St. Clair Av. W.
Suite 1500
Toronto, Ontario
Canada M5V 1W4
T 416.941.4114
F 416.941.4114

GF 580 THE EAST MALL LTD
TORONTO, ONTARIO

Sheet Title:
SECOND FLOOR
3RD - 5TH FLOORS

Scale: 1:100

Project Number: 07816.000

Drawing Number: A-202

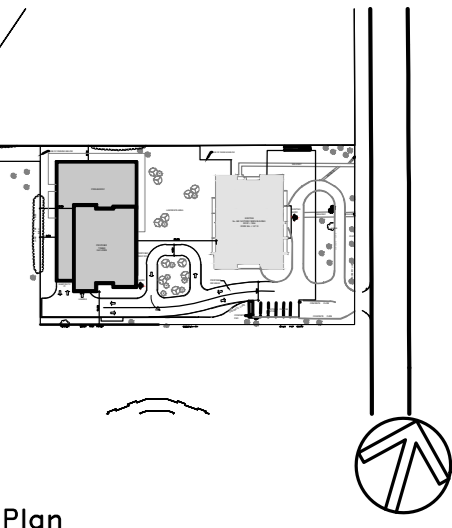

Key Plan

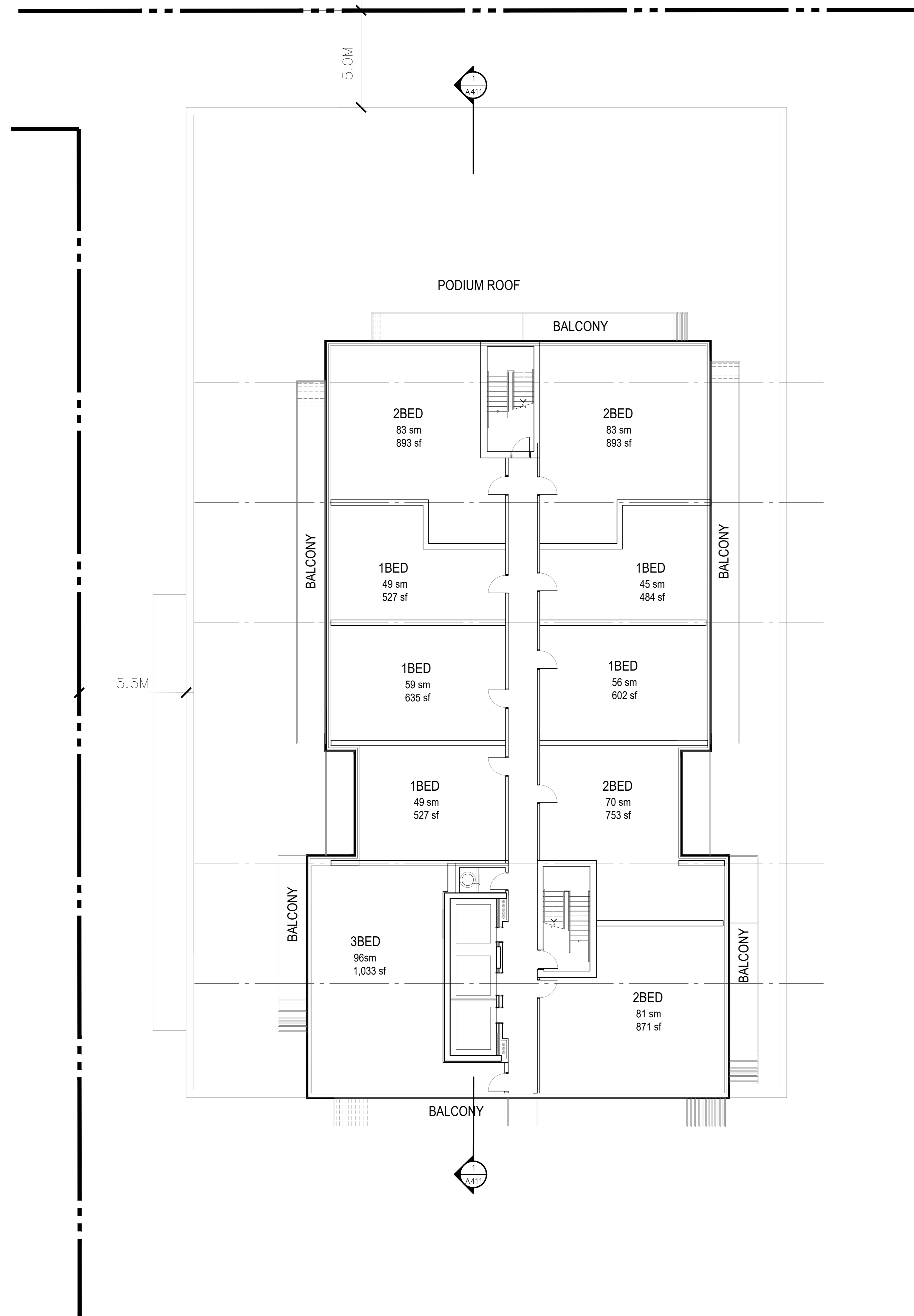

2 TYPICAL FLOOR PLAN (7TH-20TH)

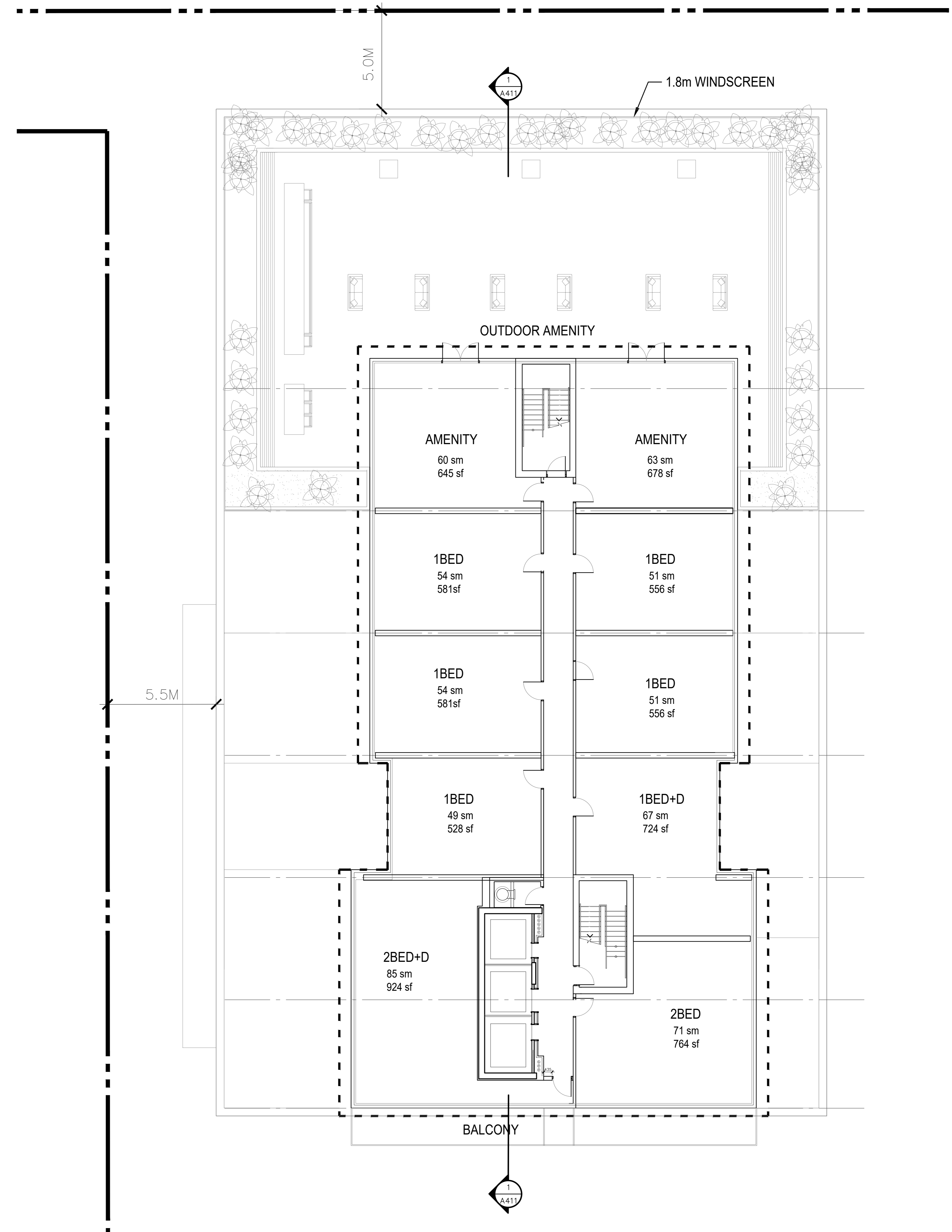

1 TYPICAL FLOOR PLAN (6TH)

WITHOUT PREJUDICE

Item	Description	Date
	WITHOUT PREJUDICE	2023/FEB/09
	REVISSED FOR WITHOUT PREJUDICE MEETING	2023/NOV/16
A	ISSUED FOR REZONING APPLICATION	2021/AUL/30
	ISSUED FOR PROGRESS SET	2021/MAY/31
	ISSUED FOR PRE-APPLICATION MEETING	2021/JAN/27
	PRELIMINARY SET - ISSUE TO CLIENT	2021/JAN/08

ISSUES/REVISIONS

Item	Description	Date

Check and verify all dimensions and report any discrepancies to the Consultant whose seal is affixed to this drawing. This drawing is not to be used for the purpose of setting out.

This drawing shall not be used for construction purposes until signed and sealed in the space below by the above mentioned Consultant.

Issued For Construction: _____ Date: _____

WZMH ARCHITECTS
 95 St. Clair Av. W
 Suite 1500
 Toronto, Ontario
 Canada M5V 1W4
 T 416.941.4114
 F 416.941.4114

GF 580 THE EAST MALL LTD
 TORONTO, ONTARIO

Sheet Title:
 6TH FLOOR
 7TH FLOOR - 20TH FLOOR

Scale: 1:100
 Project Number: 07816.000
 Drawing Number: A-203

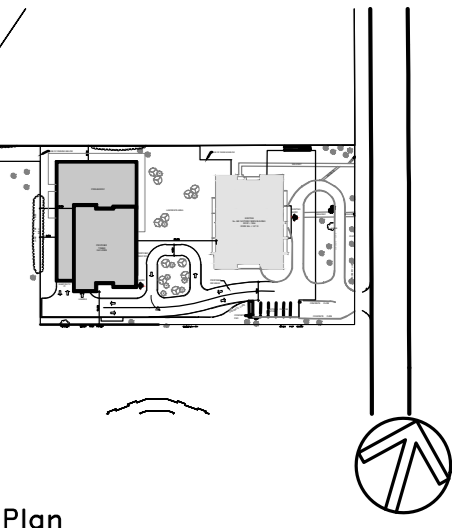

Key Plan

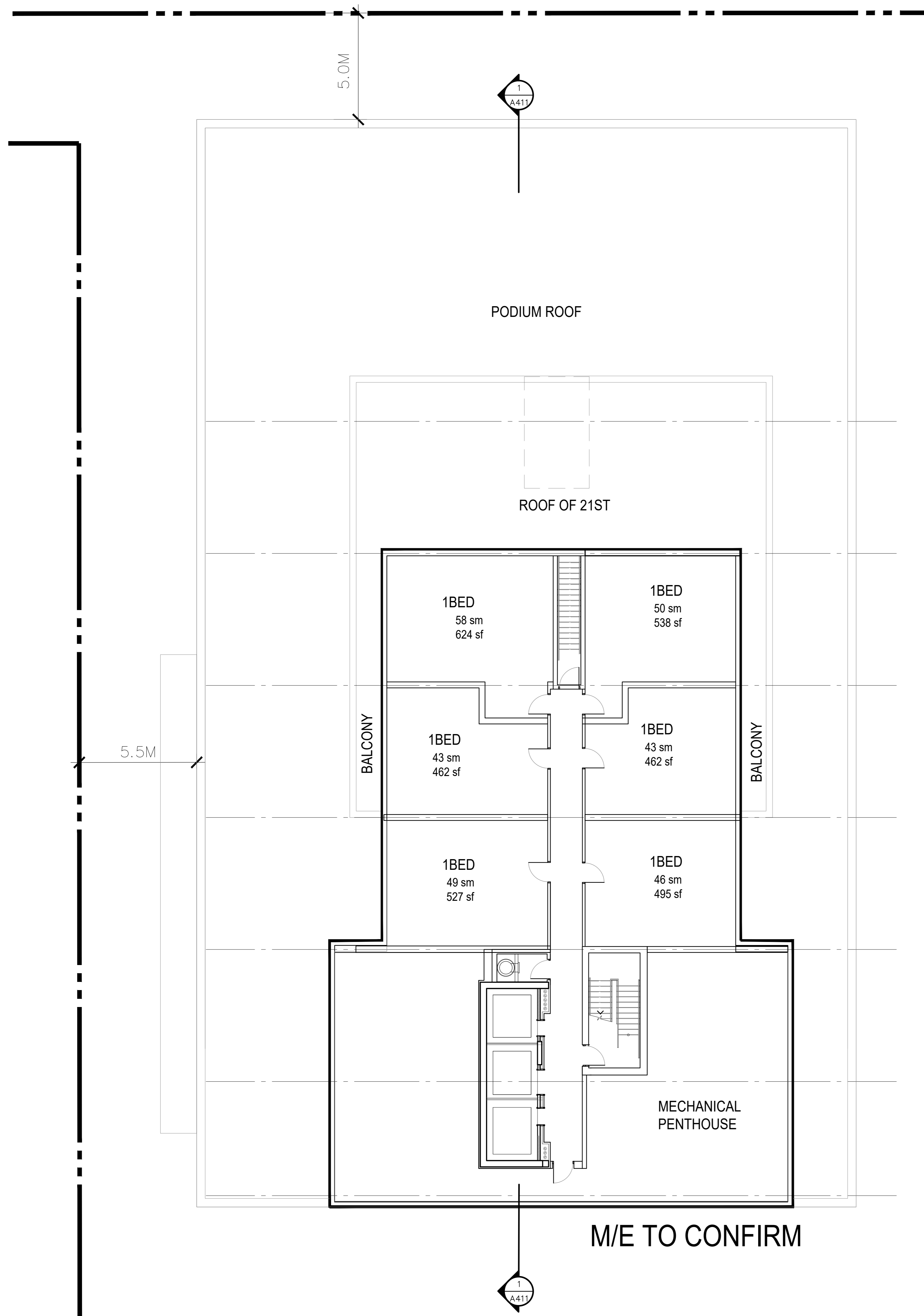

2 22ND FLOOR - MECHANICAL PENTHOUSE
A204

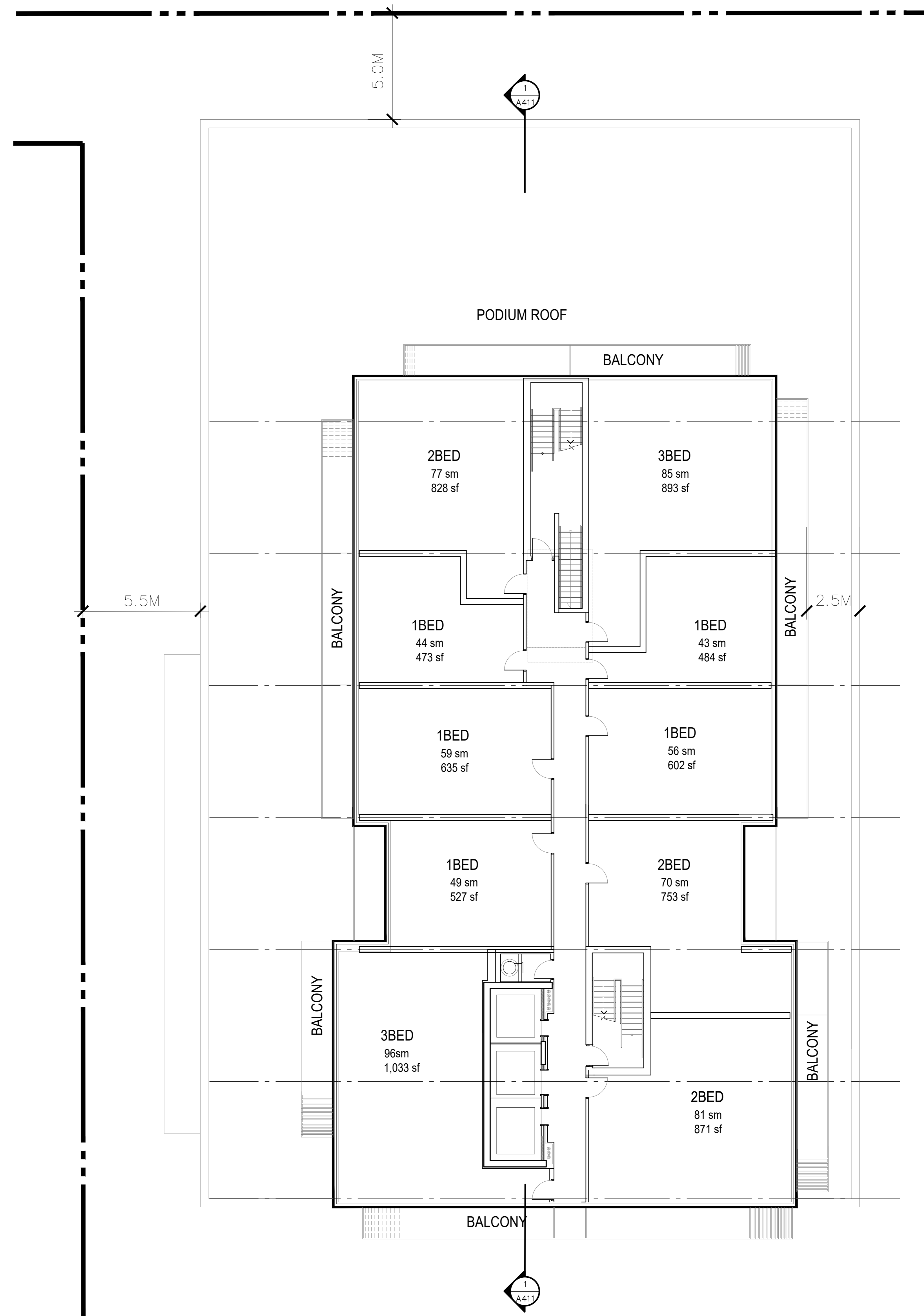

1 21ST FLOOR
A204

WITHOUT PREJUDICE

Item	Description	Date
	WITHOUT PREJUDICE	2023/FEB/09
	REQUESTED FOR PREJUDICE MEETING	2023/NOV/16
A	ISSUED FOR REZONING APPLICATION	2021/AUL/30
	ISSUED FOR PROGRESS SET	2021/MAY/31
	ISSUED FOR PRE-APPLICATION MEETING	2021/JAN/27
	PRELIMINARY SET - ISSUE TO CLIENT	2021/JAN/08

ISSUES/REVISIONS

Item	Description	Date

Check and verify all dimensions and report any discrepancies to the Consultant whose seal is affixed to this drawing. This drawing is not to be used for the purpose of verifying construction.

This drawing shall not be used for construction purposes until signed and sealed in the space below by the above mentioned Consultant.

Issued For Construction: _____ Date: _____

WZMH ARCHITECTS
 95 St. Clair Av. W
 Suite 1500
 Toronto, Ontario
 Canada M5V 1W4
 T 416.941.4114
 F 416.941.8174

GF 580 THE EAST MALL LTD
 TORONTO, ONTARIO

Sheet Title:
 21ST FLOOR
 22ND-MECH PENTHOUSE

Scale: 1:100
 Project Number: 07816.000
 Drawing Number: A-204

Plot Time: Jan 24, 2023 - 11:28am
 Drawing Name: \\wzmh\Projects\7816\7816.002\6_Drawings-Design (SD-30)\A-204_Typical.dwg

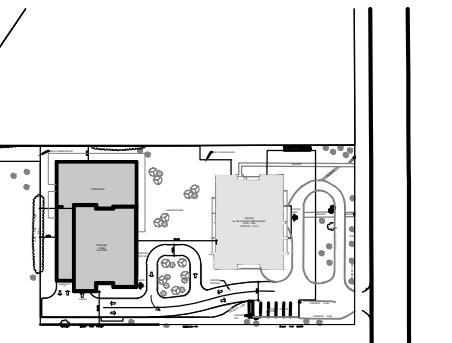

Key Plan



FLOOR	ELEVATION
MPH	+219.00
ROOF	285.00
22ND FLOOR	345.00
21TH FLOOR	345.00
20TH FLOOR	295.00
19TH FLOOR	295.00
18TH FLOOR	295.00
17TH FLOOR	295.00
16TH FLOOR	295.00
15TH FLOOR	295.00
14TH FLOOR	295.00
13TH FLOOR	295.00
12TH FLOOR	295.00
11TH FLOOR	295.00
10TH FLOOR	335.00
9TH FLOOR	295.00
8TH FLOOR	295.00
7TH FLOOR	295.00
6TH FLOOR	360.00
5TH FLOOR	360.00
4TH FLOOR	295.00
3RD FLOOR	295.00
2ND FLOOR	295.00
GROUND FLOOR	000

ESTABLISHED GRADE
±000 = 147.00

1 WEST ELEVATION
A400

WITHOUT PREJUDICE

Item	Description	Date
	WITHOUT PREJUDICE	2023/FEB/09
	REVISED FOR WITHOUT PREJUDICE MEETING	2023/NOV/16
A	ISSUED FOR REZONING APPLICATION	2021/AUL/30
	ISSUED FOR PROGRESS SET	2021/MAY/31
	ISSUED FOR PRE-APPLICATION MEETING	2021/JAN/27
	PRELIMINARY SET - ISSUE TO CLIENT	2021/JAN/08

Check and verify all dimensions and report any discrepancies to the Consultant whose seal is affixed to this drawing. This drawing is not to be used for the purpose of setting out. This drawing shall not be used for construction purposes until signed and sealed in the space below by the above mentioned Consultant.

Issued For Construction: _____ Date: _____

WZMH ARCHITECTS
95 St. Clair Av. W
Suite 1500
Toronto, Ontario
Canada M5V 1W4
T 416.941.4111
F 416.941.4114

GF 580 THE EAST MALL LTD
TORONTO, ONTARIO

Sheet Title:
**BUILDING ELEVATIONS
WEST ELEVATION**

Scale: 1:150
Project Number: 07816.000
Drawing Number: A-400

Plot Time: Nov 15, 2022 - 2:39pm
Drawing Name: \\wzmm\Projects\7816\7816.002\6_Drawings-Design (SD-00)\A-400 BUILDING ELEVATIONS.dwg

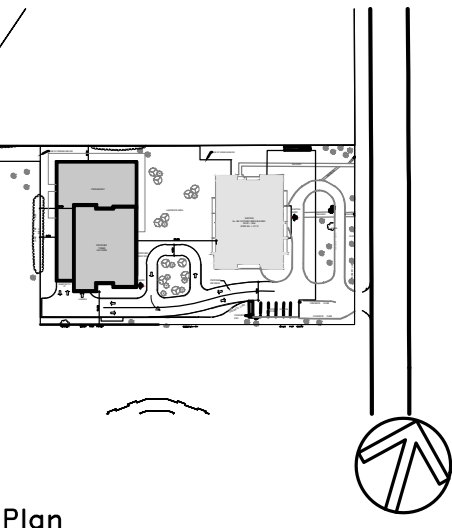

Key Plan

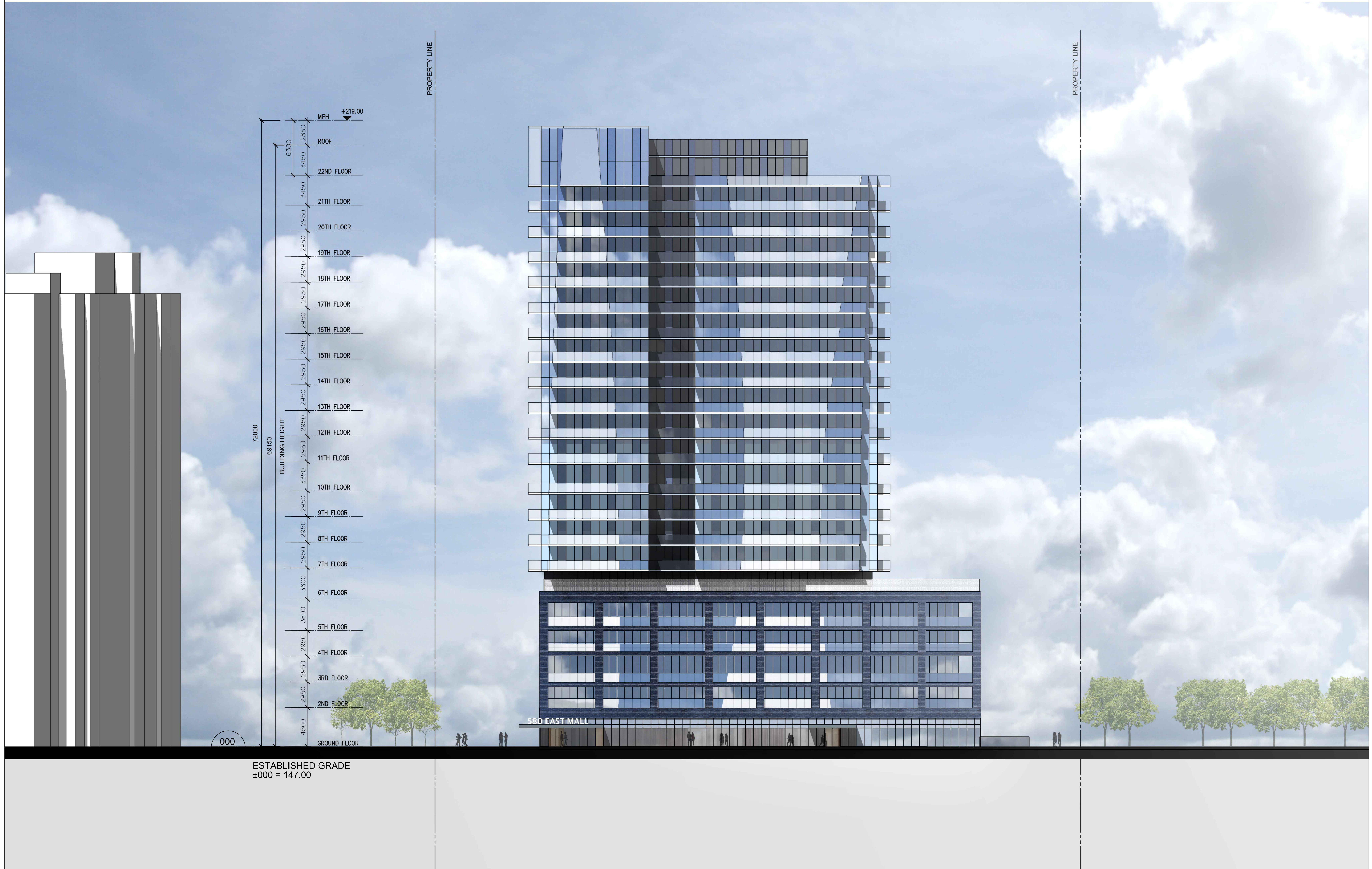

WITHOUT PREJUDICE

Item	Description	Date
	WITHOUT PREJUDICE	2023/FEB/09
	REISSUED FOR WITHOUT PREJUDICE MEETING	2023/NOV/16
A	ISSUED FOR REZONING APPLICATION	2021/AUL/30
	ISSUED FOR PROGRESS SET	2021/MAY/31
	ISSUED FOR PRE-APPLICATION MEETING	2021/JAN/27
	PRELIMINARY SET - ISSUE TO CLIENT	2021/JAN/08

Item	Description	Date
	ISSUES/REVISIONS	

Check and verify all dimensions and report any discrepancies to the Consultant whose seal is affixed to this drawing. This drawing is not to be used for the purpose of setting out.

This drawing shall not be used for construction purposes until signed and sealed in the space below by the above mentioned Consultant.

Issued For Construction: _____ Date: _____

WZMH ARCHITECTS
 95 St. Clair Av. W
 Suite 1500
 Toronto, Ontario
 Canada M5V 1W4
 T 416.941.4111
 F 416.941.4114

GF 580 THE EAST MALL LTD
 TORONTO, ONTARIO

Sheet Title:
**BUILDING ELEVATIONS
 EAST ELEVATION**

Scale: 1:150
 Project Number: 07816.000
 Drawing Number: A-401

1 EAST ELEVATION
 A401

Plot Time: Nov 15, 2022 - 2:39pm
 Drawing Name: \\wzmb\Projects\7816\7816.002\6_Drawings-Design (SD-00)\A-400 BUILDING ELEVATIONS.dwg

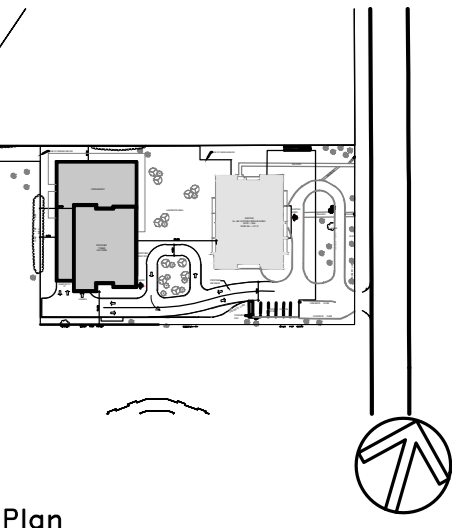

Key Plan



WITHOUT PREJUDICE

WITHOUT PREJUDICE	2023/FEB/09
REISSUED FOR WITHOUT PREJUDICE MEETING	2023/NOV/16
A ISSUED FOR REZONING APPLICATION	2021/AUL/30
ISSUED FOR PROGRESS SET	2021/MAY/31
ISSUED FOR PRE-APPLICATION MEETING	2021/JAN/27
PRELIMINARY SET - ISSUE TO CLIENT	2021/JAN/08

ISSUES/REVISIONS

Item	Description	Date

Check and verify all dimensions and report any discrepancies to the Consultant whose seal is affixed to this drawing. This drawing is not to be used for the purpose of setting out.
This drawing shall not be used for construction purposes until signed and sealed in the space below by the above mentioned Consultant.

Issued For Construction: _____ Date: _____

WZMH ARCHITECTS
 95 St. Clair Av. W
 Suite 1500
 Toronto, Ontario
 Canada M5V 1W4
 T 416.961.4111
 F 416.961.4114

GF 580 THE EAST MALL LTD
 TORONTO, ONTARIO

Sheet Title:
BUILDING ELEVATIONS
SOUTH ELEVATION

Scale: 1:150
 Project Number: 07816.000
 Drawing Number: A-402

ESTABLISHED GRADE
 ±000 = 147.00

1 SOUTH ELEVATION

Plot Time: Nov 15, 2022 - 2:40pm
 Drawing Name: \\wzmh\Projects\7816\7816.002\6_Drawings-Design (SD-00)\A-400 BUILDING ELEVATIONS.dwg

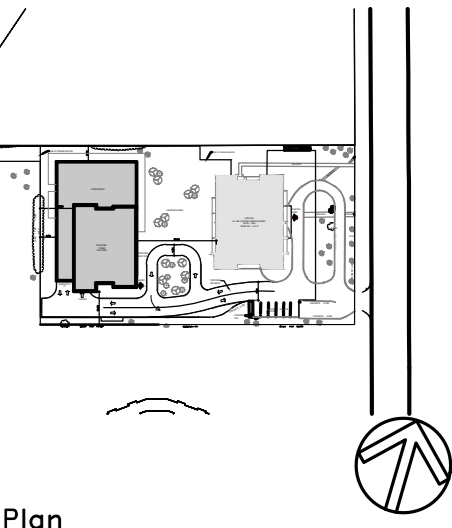

Key Plan



ESTABLISHED GRADE
±000 = 147.00

WITHOUT PREJUDICE

Item	Description	Date
	WITHOUT PREJUDICE	2023/FEB/09
	REISSUED FOR WITHOUT PREJUDICE MEETING	2023/NOV/16
A	ISSUED FOR REZONING APPLICATION	2021/AUL/30
	ISSUED FOR PROGRESS SET	2021/MAY/31
	ISSUED FOR PRE-APPLICATION MEETING	2021/JAN/27
	PRELIMINARY SET - ISSUE TO CLIENT	2021/JAN/08

Item	Description	Date
	ISSUES/REVISIONS	

Check and verify all dimensions and report any discrepancies to the Consultant whose seal is affixed to this drawing. This drawing is not to be used for the purpose of setting out.

This drawing shall not be used for construction purposes until signed and sealed in the space below by the above mentioned Consultant.

Issued For Construction: _____ Date: _____

WZMH ARCHITECTS
 95 St. Clair Av. W
 Suite 1500
 Toronto, Ontario
 Canada M5V 1W4
 T 416.941.4111
 F 416.941.4114

GF 580 THE EAST MALL LTD
 TORONTO, ONTARIO

Sheet Title:
**BUILDING ELEVATIONS
 NORTH ELEVATION**

Scale: 1:150
 Project Number: 07816.000
 Drawing Number: A-403

Plot Time: Nov 15, 2022 - 2:40pm
 Drawing Name: \\wzmm\Projects\7816\7816.002\6_Drawings-Design (SD-00)\A-400 BUILDING ELEVATIONS.dwg

1 NORTH ELEVATION

A403

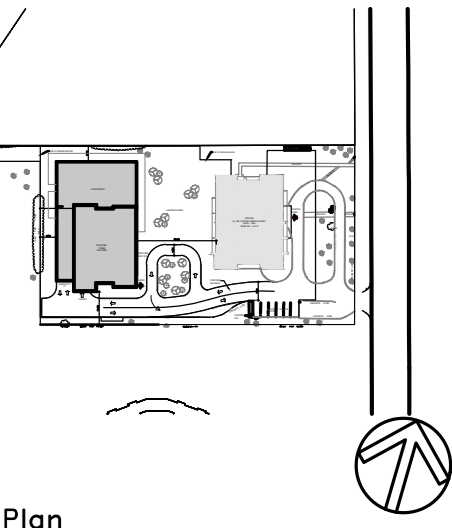

Key Plan

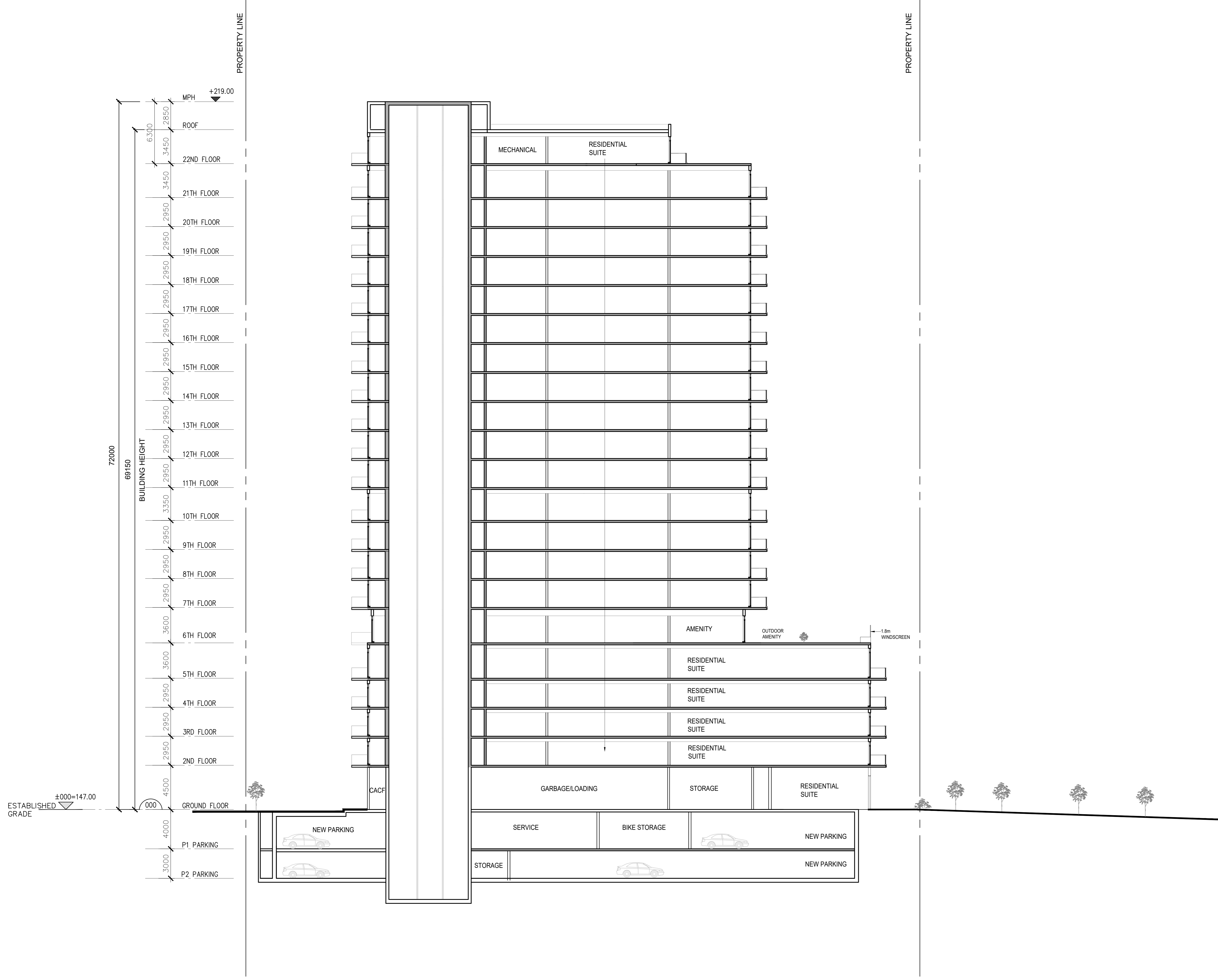

WITHOUT PREJUDICE

Item	Description	Date
	WITHOUT PREJUDICE	2023/FEB/09
	RESUBMITTED FOR WITHOUT PREJUDICE MEETING	2023/NOV/16
A	ISSUED FOR REZONING APPLICATION	2021/AUL/30
	ISSUED FOR PROGRESS SET	2021/MAY/31
	ISSUED FOR PRE-APPLICATION MEETING	2021/JAN/27
	PRELIMINARY SET - ISSUE TO CLIENT	2021/JAN/08

Item	Description	Date
	ISSUES/REVISIONS	

Check and verify all dimensions and report any discrepancies to the Consultant whose seal is affixed to this drawing. This drawing is not to be used for the purpose of setting out.

This drawing shall not be used for construction purposes until signed and sealed in the space below by the above mentioned Consultant.

Issued For Construction: _____ Date: _____

WZMH ARCHITECTS
 95 St. Clair Av. W
 Suite 1500
 Toronto, Ontario
 Canada M6A 1W4
 T 416.941.4111
 F 416.941.4114

GF 580 THE EAST MALL LTD
 TORONTO, ONTARIO

Sheet Title:
**BUILDING SECTION
 NORTH-SOUTH**

Scale: 1:150
 Project Number: 07816.000
 Drawing Number: A-411

Plot Time: Nov 15, 2022 - 2:39pm
 Drawing Name: \\wzmb\Projects\7816\7816.002\6_Drawings-Design (SD-00)\A-411 BUILDING SECTIONS.dwg

1 BUILDING SECTION (N-S)

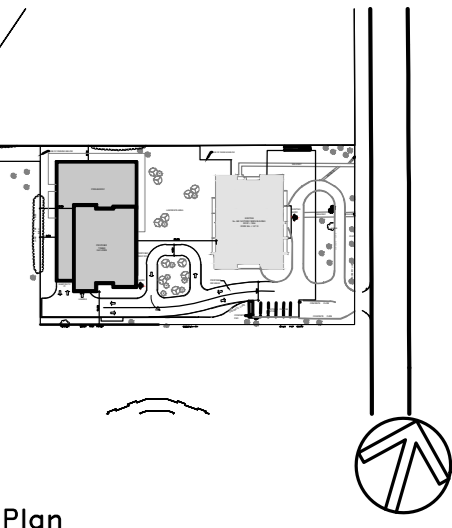

Key Plan

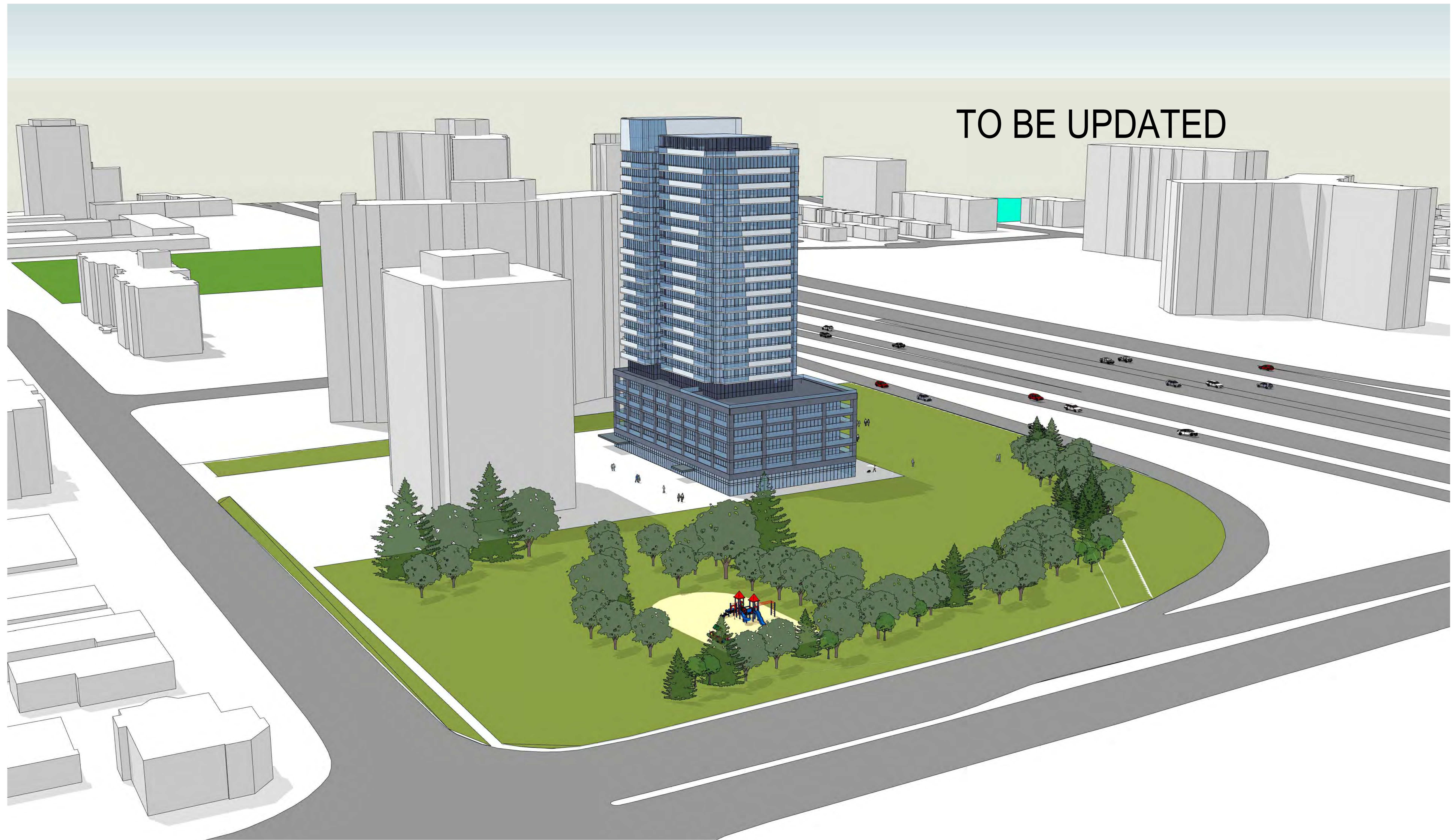

TO BE UPDATED

WITHOUT PREJUDICE

WITHOUT PREJUDICE	2023FEB09
REISSUED FOR WITHOUT PREJUDICE MEETING	2023NOV16
A ISSUED FOR REZONING APPLICATION	2021AUG30
ISSUED FOR PROGRESS SET	2021MAY31
ISSUED FOR PRE-APPLICATION MEETING	2021JAN27
PRELIMINARY SET - ISSUE TO CLIENT	2021JAN08

ISSUES/REVISIONS

Check and verify all dimensions and report any discrepancies to the Consultant whose seal is affixed to this drawing. This drawing is not to be used for the purpose of setting out.

This drawing shall not be used for construction purposes until signed and sealed in the space below by the above mentioned Consultant.

WZMH ARCHITECTS
 95 St. Clair Av. W
 Suite 1500
 Toronto, Ontario
 Canada M5V 1W4
 T 416.941.4111
 F 416.941.8174

GF 580 THE EAST MALL LTD
TORONTO, ONTARIO

Sheet Title:
3D VIEWS

Scale: NTS
 Project Number: 07816.000
 Drawing Number: A-420

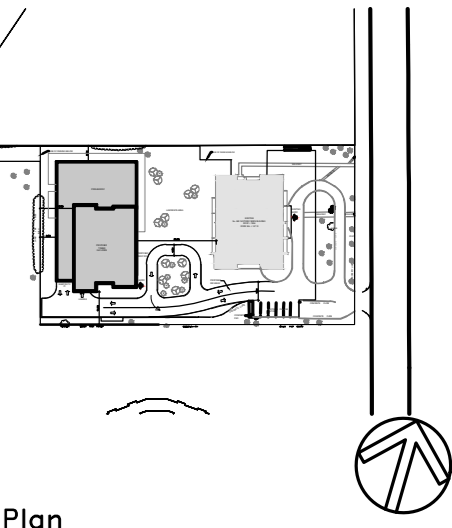

Key Plan

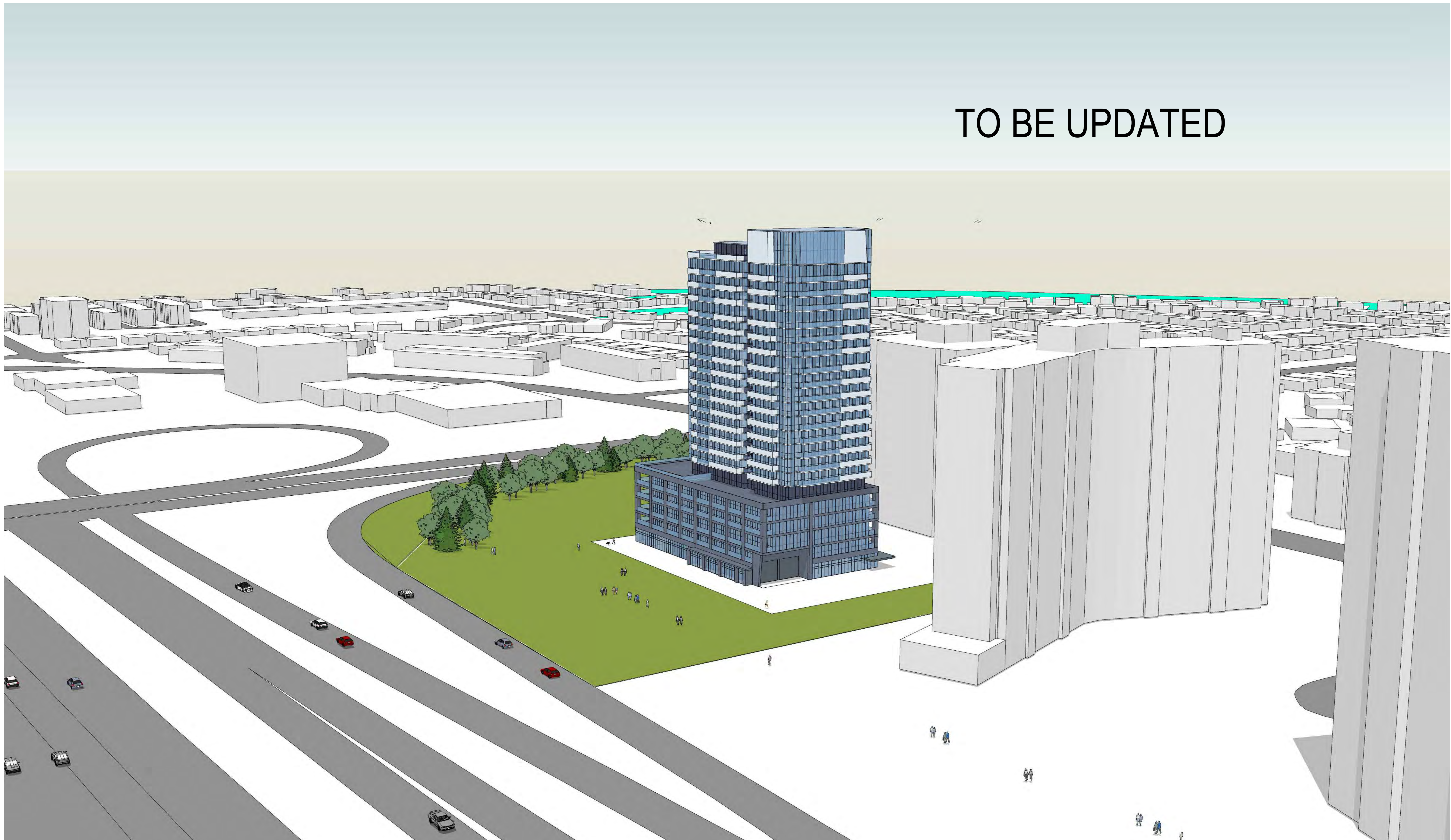

TO BE UPDATED

WITHOUT PREJUDICE

WITHOUT PREJUDICE	2023/FEB/09
REISSUED FOR WITHOUT PREJUDICE MEETING	2023/NOV/16
A ISSUED FOR REZONING APPLICATION	2021/AUL/30
ISSUED FOR PROGRESS SET	2021/MAY/31
ISSUED FOR PRE-APPLICATION MEETING	2021/JAN/27
PRELIMINARY SET - ISSUE TO CLIENT	2021/JAN/08

ISSUES/REVISIONS

Check and verify all dimensions and report any discrepancies to the Consultant whose seal is affixed to this drawing. This drawing is not to be used for the purpose of setting out.

This drawing shall not be used for construction purposes until signed and sealed in the space below by the above mentioned Consultant.

Issued For Construction: _____ Date: _____

WZMH ARCHITECTS
 95 St. Clair Av. W
 Suite 1500
 Toronto, Ontario
 Canada M5V 1W4
 T 416.941.4111
 F 416.941.4114

GF 580 THE EAST MALL LTD
TORONTO, ONTARIO

Sheet Title:
3D VIEWS
EAST MALL ROAD

Scale: NTS

Project Number: 07816.000

Drawing Number: A-421

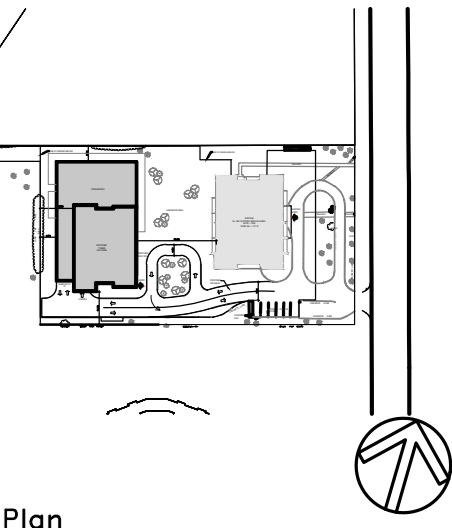

Key Plan

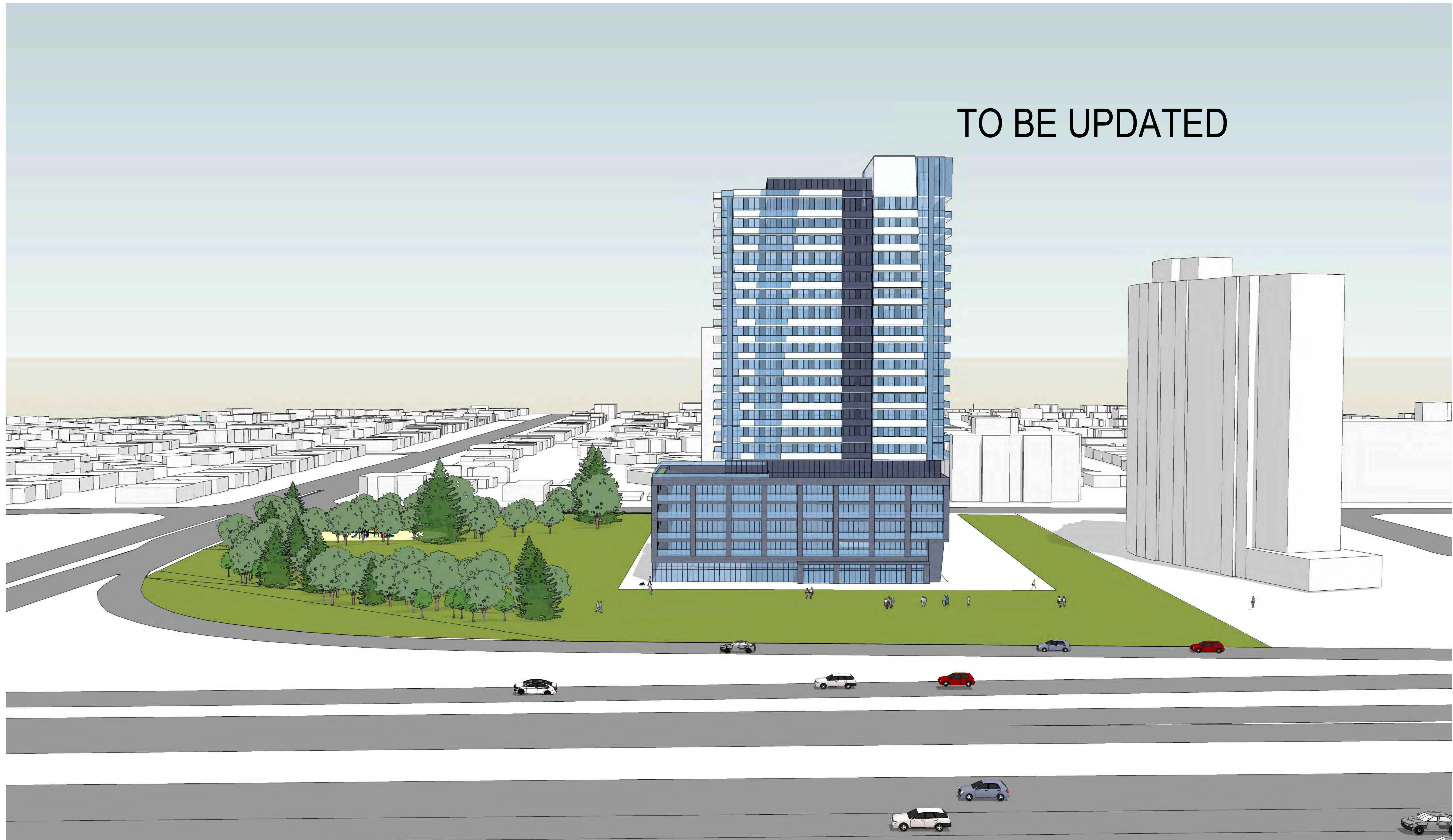

TO BE UPDATED

WITHOUT PREJUDICE

WITHOUT PREJUDICE	2023/FEB/09
REISSUED FOR WITHOUT PREJUDICE MEETING	2023/NOV/16
A ISSUED FOR REZONING APPLICATION	2021/AUL/30
ISSUED FOR PROGRESS SET	2021/MAY/31
ISSUED FOR PRE-APPLICATION MEETING	2021/JAN/27
PRELIMINARY SET - ISSUE TO CLIENT	2021/JAN/08

ISSUES/REVISIONS

Item	Description	Date

Check and verify all dimensions and report any discrepancies to the Consultant whose seal is affixed to this drawing. This drawing is not to be used for the purpose of setting out.

This drawing shall not be used for construction purposes until signed and sealed in the space below by the above mentioned Consultant.

Issued For Construction: _____ Date: _____

WZMH ARCHITECTS
95 St. Clair Av. W.
Suite 1500
Toronto, Ontario
Canada M5V 1W4
T 416.941.4111
F 416.941.4114

GF 580 THE EAST MALL LTD
TORONTO, ONTARIO

Sheet Title:
3D VIEWS

Scale: NTS
Project Number: 07816.000
Drawing Number: A-422

Plot Time: Nov 15, 2022 - 2:41pm
Drawing Name: \\wzmb\Projects\7816\7816.002\6_Drawings\Design (SD-00)\A-422-e_3D_VIEWS.dwg

1 VIEW FROM NORTH