

666 Spadina Avenue - Encroachment Appeal - Walkway Platform and Bollards

Date: March 13, 2026

To: Toronto and East York Community Council

From: Director, Street Permits, Transportation Services

Wards: Ward 11, University-Rosedale

SUMMARY

This staff report is about a matter that Community Council has delegated authority from City Council to make a final decision.

The purpose of this report is for Toronto and East York Community Council to consider an appeal from the property owner of 666 Spadina Avenue regarding their encroachment application. The proposed walkway platform and bollards do not comply with City of Toronto Municipal Code Chapter 743, Streets and Sidewalks, Use Of, which permits only soft landscaping within 0.50 metres of the edge of sidewalk located closest to the street line.

The property owner is seeking authorization from the Toronto and East York Community Council to construct and maintain a walkway platform and two bollards within the public right-of-way at 666 Spadina Avenue, despite this proposal being in contravention of the Toronto Municipal Code. The proposed installation would maintain a minimum pedestrian clearway of 2.10 to 4.68 metres on the adjacent sidewalk, meeting the required minimum of 2.10 metres for permitted encroachments.

RECOMMENDATIONS

The Director, Street Permits, Transportation Services recommends that:

1. Toronto and East York Community Council authorize the General Manager of Transportation Services to enter into an encroachment agreement with the property owner of 666 Spadina Avenue, to permit the construction and maintenance of a walkway platform and bollards within the sidewalk fronting 666 Spadina Avenue, subject but not limited to, the following conditions:

- a. Indemnify the City from and against all actions, suits, claims or demands and from all loss, costs, damages, and expenses that may result from such permission granted;
- b. Maintain the walkway platform and bollards at their own expense in good repair and a condition satisfactory to the General Manager of Transportation Services and will not make any additions or modifications to the encroachment beyond what is allowed under the terms of the Agreement;
- c. Accept such additional conditions as the City Solicitor or the General Manager of Transportation Services may deem necessary in the interest of the City;
- d. Remove the walkway platform and bollards upon receiving written notice from the General Manager of Transportation Services to do so;
- e. The property owner will enter into an encroachment agreement with the City of Toronto, at the applicant's expense, and assume all liability and damages related to the encroachment;
- f. The property owner shall agree that the City and/or utility companies may remove the encroachment at any time in order to install or maintain services or infrastructure within the affected public right of way with no obligation to replace them; and
- g. The property owner shall obtain all necessary permits for the encroachment from Toronto Building, if required.

FINANCIAL IMPACT

There are no financial impacts resulting from the adoption of the recommendations in this report.

DECISION HISTORY

This report addresses a new initiative.

COMMENTS

An encroachment application was received on August 3, 2025, from the agent, The Firm Developments, on behalf of the owner of 666 Spadina Avenue requesting permission to construct a walkway platform and install bollards within the sidewalk on Spadina Avenue of the subject property. The applicant was advised that the proposed walkway

platform and bollards are not eligible for an encroachment agreement as they contravene the City of Toronto Municipal Code Chapter 743, Streets and Sidewalks, Use Of. Specifically. The Code does not permit encroachments, other than soft landscaping, within 0.50 metres of the sidewalk edge located closest to the street line. An appeal was subsequently received from the applicant.

Transportation Services has reviewed the application and the property located at 666 Spadina Avenue. The applicant has indicated that the proposed platform is required to mitigate an approximate 0.30 to 0.40 metre vertical grade difference between the interior finished floor elevation and the adjacent sidewalk. The platform is intended as a corrective measure to address a design oversight related to the existing grading conditions.

The proposed encroachment contravenes Code Chapter 743 as follows:

- The walkway platform and bollards are proposed to extend from the exterior building wall into the public right-of-way encroaching 0.91 metres and will be located directly within the City of Toronto sidewalk. This contravenes the Municipal Code Chapter 743 article 743-31.E.(2) requirement that "E. Unless otherwise specified in this chapter, no encroachments other than soft landscaping are permitted: ... (2) Within 0.50 metres of the edge of sidewalk located closest to the street line";

It should be noted that the proposed encroachment will require the removal of a section of City of Toronto sidewalk and will reduce the pedestrian clearway from approximately 4.78 metres to a range of 2.10 metres at its narrowest point and 4.68 metres at its widest point.

In accordance with Section 743-48 of the Toronto Municipal Code, Transportation Services has responded to the appeal by preparing this report for consideration by the Toronto and East York Community Council and to provide the applicant with an opportunity to be heard.

Transportation Services has reviewed the application and is of the opinion that the proposed walkway platform and bollards will not adversely impact the public right-of-way, including pedestrian movements, vehicular traffic on the adjacent streets, or the City's ability to properly maintain the right-of-way. Accordingly, Transportation Services recommends that Toronto and East York authorize the encroachment in its proposed configuration.

The Ward Councillor has been advised of the recommendations in this report.

Drawings of the proposed encroachment and photos of the existing conditions at 666 Spadina Avenue are shown in Attachments 1 to 5.

CONTACT

Elio Capizzano, Manager, Construction Activity, Street Permits - Transportation Services, 416-392-7878, Elio.Capizzano@toronto.ca

SIGNATURE

Nazzareno A. Capano
A/Director, Street Permits, Transportation Services

ATTACHMENTS

Attachment 1: Site Plan Drawing of Proposed Encroachment – 666 Spadina Avenue
Attachment 2: Cross-Section Drawings & Detail of Proposed Encroachment – 666 Spadina Ave
Attachment 3: Photo of Existing Condition looking North on Spadina Avenue – 666 Spadina Ave
Attachment 4: Photo of Existing Condition looking South on Spadina Avenue – 666 Spadina Ave
Attachment 5: Photo of Existing Condition facing the West Elevation of 666 Spadina Ave

Attachment 2: Cross-Section Drawings & Detail of Proposed Encroachment – 666 Spadina Ave

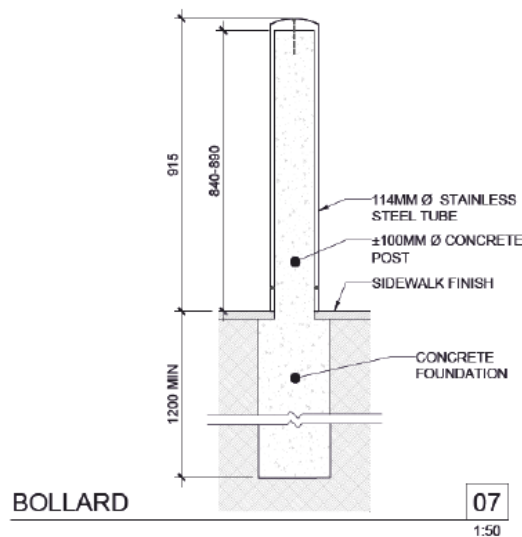
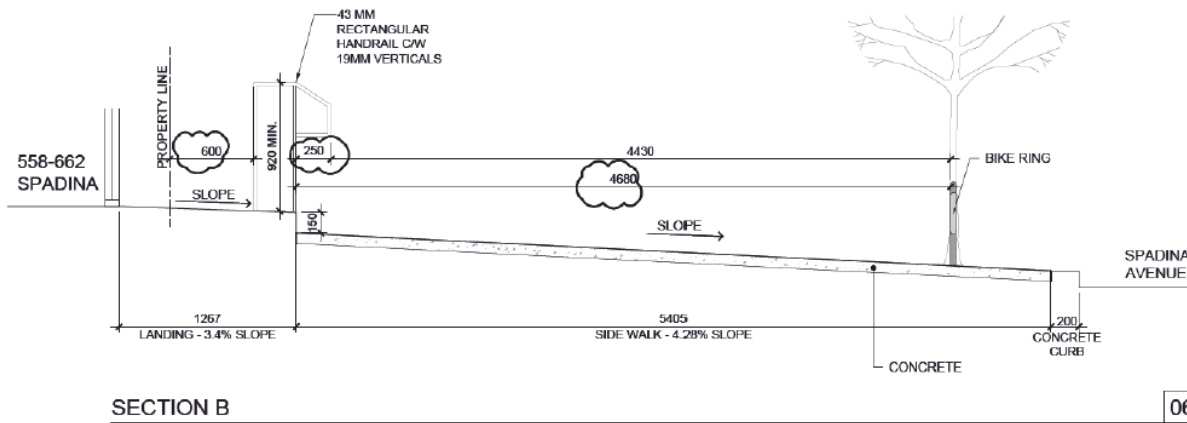
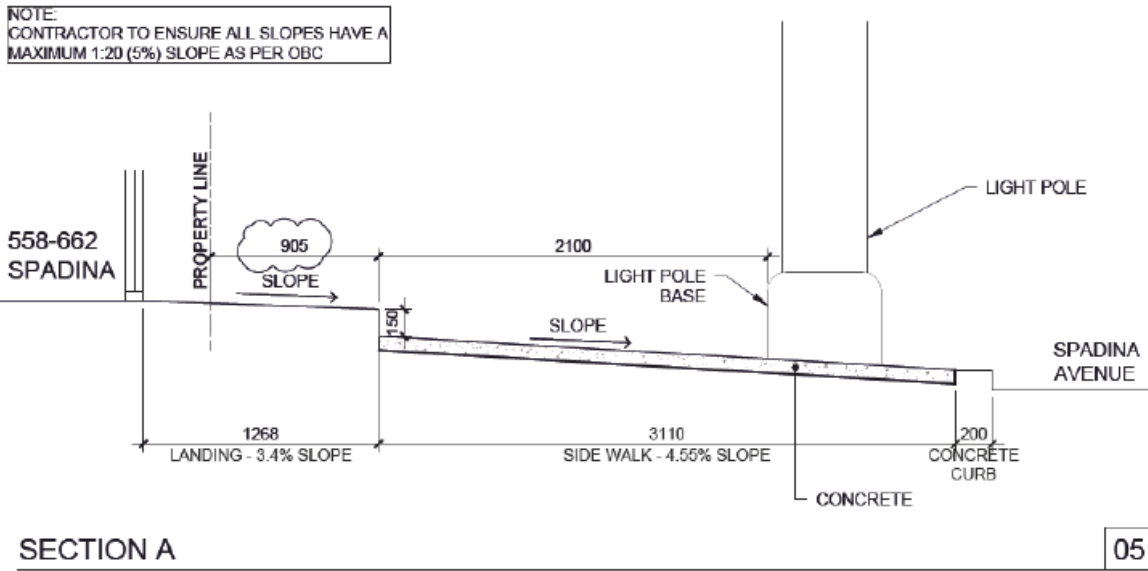

Attachment 3: Photo of Existing Condition looking North on Spadina Avenue – 666 Spadina Ave



Attachment 4: Photo of Existing Condition looking South on Spadina Avenue – 666 Spadina Ave



Attachment 5: Photo of Existing Condition facing the West Elevation of 666 Spadina Ave

