

DETAIL 1

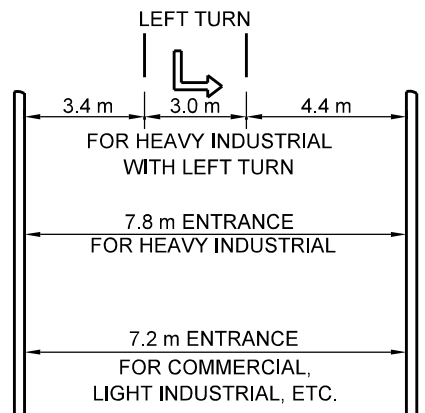

PLAN

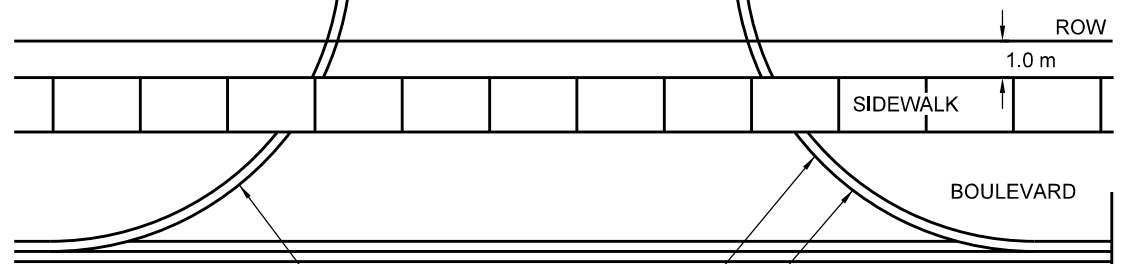

CONCRETE CURB OR CURB AND GUTTER FOR ENTRANCE WITHOUT CURB OR CURB AND GUTTER SEE DETAIL 1

R=5.0 m FOR LIGHT INDUSTRIAL ENTRANCES, COMMERCIAL AND APARTMENT ENTRANCES ON 2 LANE ROADS

R=8.0 m FOR ALL HEAVY INDUSTRIAL ENTRANCES, AND FOR COMMERCIAL AND APARTMENT ENTRANCES ON 4 LANE ROADS

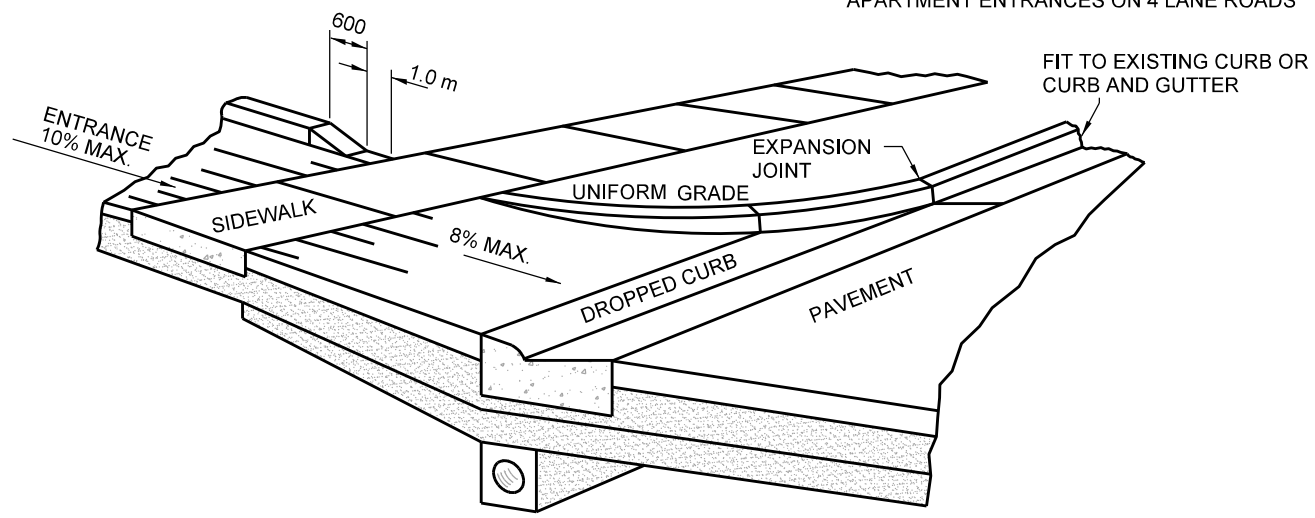

NOTES:

1. MINIMUM DIMENSIONS ARE INDICATED. MAXIMUM DIMENSIONS AS PER OWNER REQUIREMENTS.
2. PAVEMENT AND SIDEWALK STRUCTURE AT ENTRANCES SHALL BE CONSTRUCTED ACCORDING TO T-310.050-1 AND T-310.050-2.

All dimensions are in millimetres unless otherwise shown.



ENGINEERING & CONSTRUCTION SERVICES STANDARD DRAWING

REV 1 NOV 2014

URBAN ENTRANCES

T-350.01

NTS SHEET 1