

TYPICAL SUBDRAIN DETAIL FOR MONOLITHIC CONCRETE CURB AND SIDEWALK

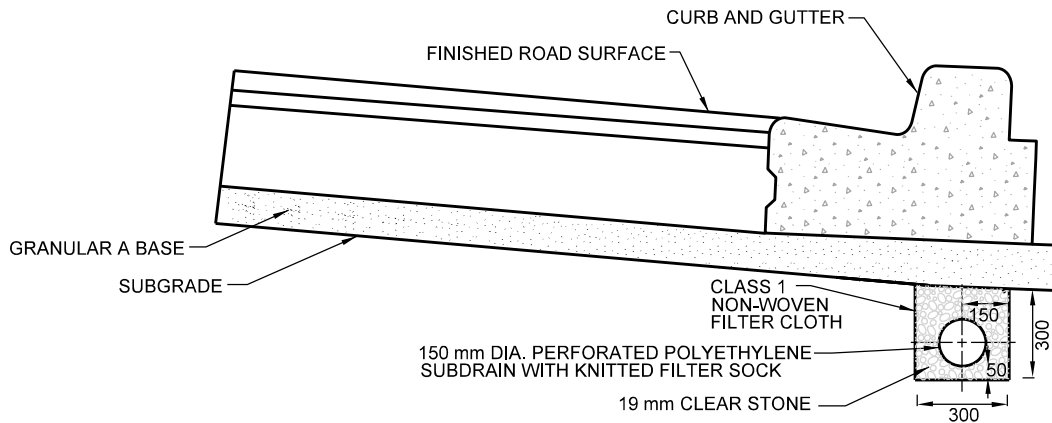

TYPICAL SUBDRAIN DETAIL FOR CONCRETE CURB AND GUTTER

NOTES:

1. FILTER CLOTH SHALL BE OVERLAPPED AT TOP AND INSTALLED ACCORDING TO TS 405.
2. IF THE EXISTING CONCRETE CURB AND GUTTER IS TO REMAIN IN PLACE, THE SUBDRAIN SHALL BE PLACED BEHIND THE CURB UNDER THE STONE BASE. THE SUBDRAIN SHALL BE PLACED AS CLOSE AS POSSIBLE TO THE CENTRELINE OF THE CURB.
3. LEDGE BEHIND CURB IS FOR ILLUSTRATION ONLY, REFER TO T-600.05-1 FOR DETAIL.

All dimensions are in millimetres unless otherwise shown.

	ENGINEERING & CONSTRUCTION SERVICES STANDARD DRAWING	REV 3	NOV 2014
	ROADWAY SUBDRAINS	T-216.02-8	
		NTS	SHEET 1