

16 M x 75 mm LONG STAINLESS STEEL LAG BOLT AND EXPANSION SHIELD. TWO REQUIRED PER ASSEMBLY.

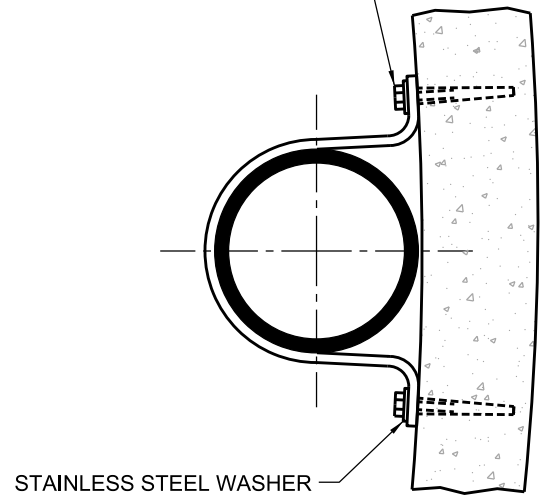

BRACKETS TO BE MADE FROM MILD STEEL STRIP, 6 mm x 75 mm x 950 mm LONG. BRACKETS TO BE GALVANIZED AFTER BENDING, AND SPACED AT 600 mm C TO C.

**SECTION THROUGH TYPICAL MAINTENANCE HOLE**

**DETAIL "1" BRACKET ASSEMBLY**

**NOTES:**

NUMBER OF BRACKET ASSEMBLIES WILL DEPEND ON LENGTH OF DROP PIPE.

All dimensions are in millimetres unless otherwise shown.



ENGINEERING AND CONSTRUCTION SERVICES STANDARD DRAWING

REV 1

APR 2013

INTERNAL DROP PIPE  
FOR MAINTENANCE HOLES

T-1003.01-2

NTS

SHEET 1