

CONNECTION WITH CROSS

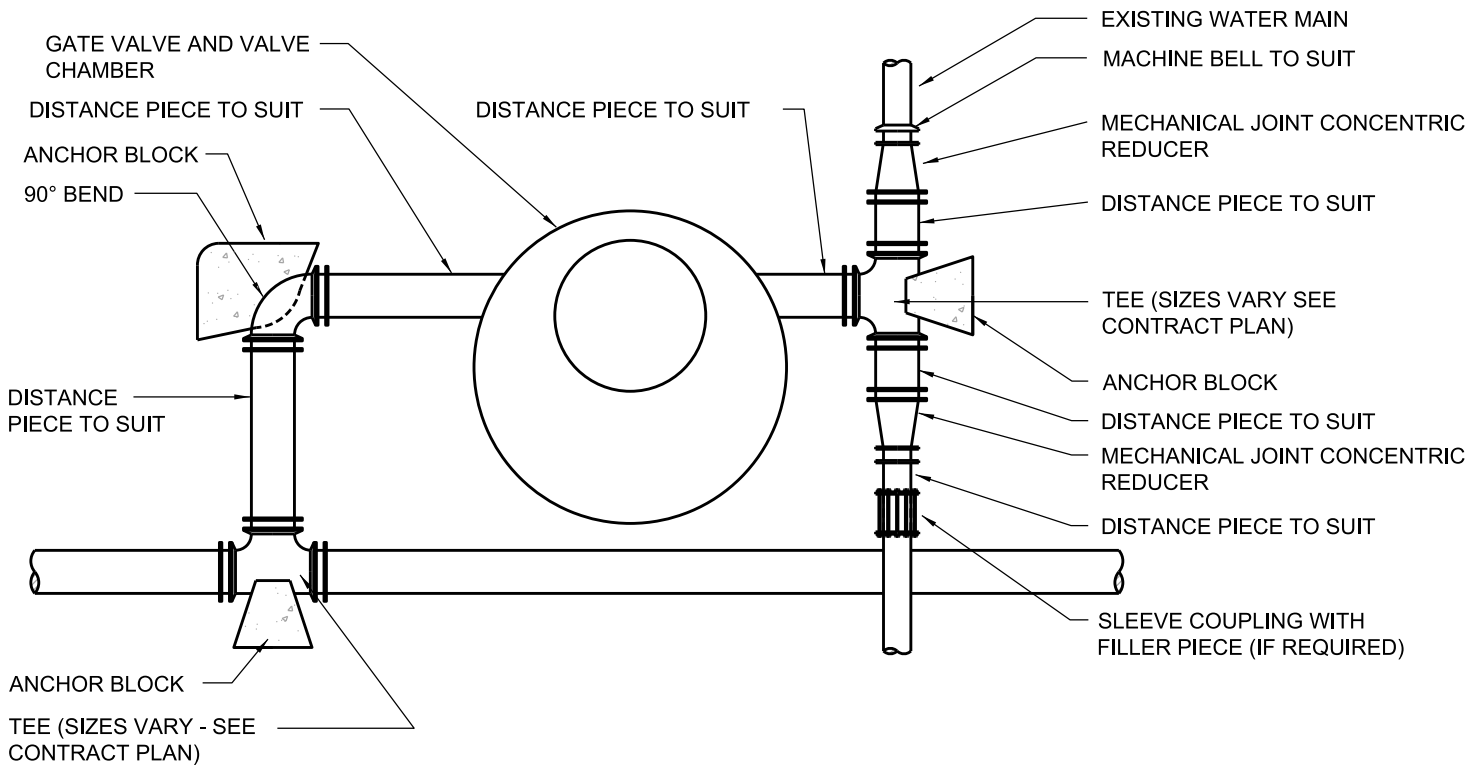

CONNECTION WITH TEE

NOTES:

THE CONTRACTOR MAY AT HIS OWN DISCRETION OMIT THE SLEEVE COUPLINGS IF HE IS ABLE TO MAKE SATISFACTORY CONNECTIONS WITHOUT THEM. HIS ATTENTION IS ALSO DIRECTED TO THE POSSIBILITY OF THE EXISTING PIPE BEING OVERSIZED.

All dimensions are in millimetres unless otherwise shown.



ENGINEERING AND CONSTRUCTION SERVICES STANDARD DRAWING

REV 2

APR 2013

DETAIL OF CONNECTIONS WITH
CROSS OR TEE FOR WATERMAINS

T-1107.04-3

NTS

SHEET 1