

A. WATER MAIN REPAIRS AND ADJUSTMENTS:

1. LENGTH OF NEW MAIN IS LESS THAN DISTANCE 'A'

INSTALL ONLY ONE MAGNESIUM ANODE TYPE 32 AT MID-POINT OF NEW MAIN.

2. LENGTH OF NEW MAIN IS MORE THAN DISTANCE 'A'

INSTALL ONE MAGNESIUM ANODE TYPE 32 AT EACH END OF NEW SECTION. IF THE LENGTH OF NEW PIPE IS MORE THAN DISTANCE 'B', INSTALL ADDITIONAL ANODES SPACED AT EQUAL INTERVALS NOT FURTHER THAN DISTANCE 'B' APART.

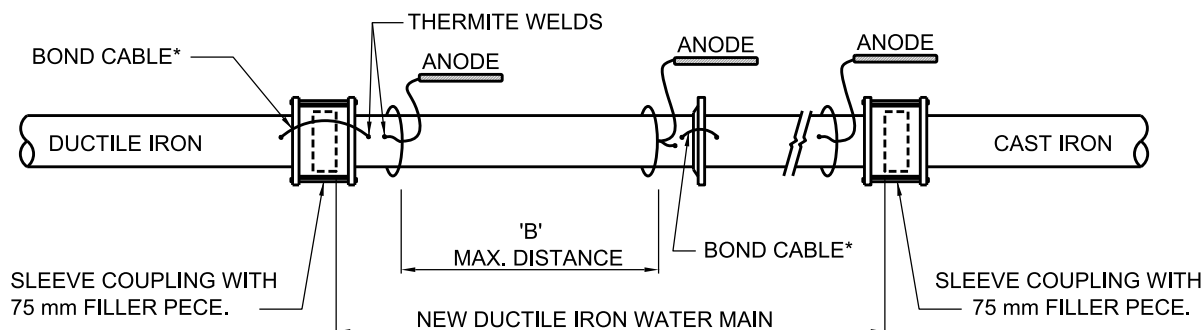

B. DUCTILE IRON WATER SERVICES:

1. LENGTH OF NEW SERVICE IS LESS THAN DISTANCE 'A'

INSTALL ONLY ONE MAGNESIUM ANODE TYPE 32 ON THE NEW SERVICE CLOSE TO THE BRANCH.

2. LENGTH OF NEW SERVICE IS MORE THAN DISTANCE 'A'

INSTALL MAGNESIUM ANODE TYPE 32 AT BRANCH AND AT STREET LINE. IF THE LENGTH OF NEW SERVICE IS MORE THAN DISTANCE 'B', INSTALL ADDITIONAL ANODES SPACED AT EQUAL INTERVALS NOT FURTHER THAN DISTANCE 'B' APART.

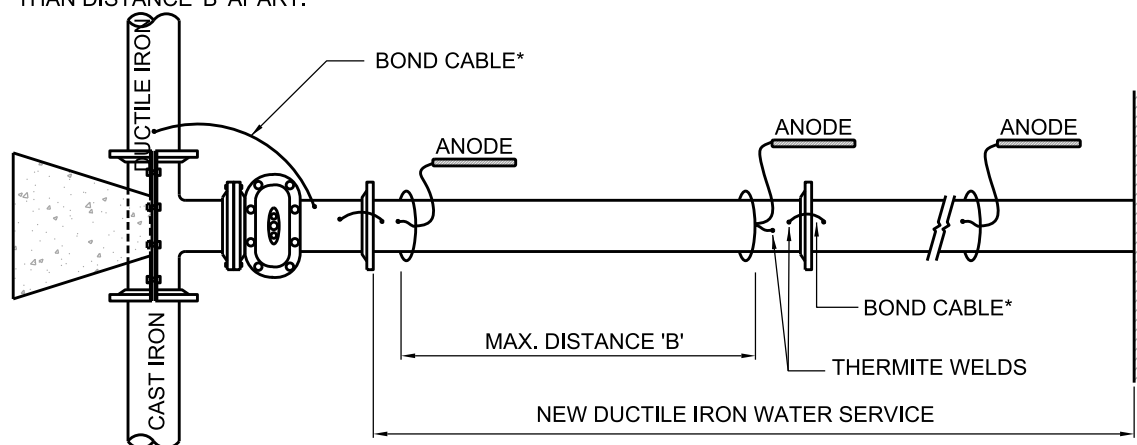

SPACING SCHEDULE FOR INSTALLATION OF MAGNESIUM ANODES ON UNCOATED DUCTILE IRON PIPES		
NEW PIPE DIAMETER	DISTANCE 'A' (1 ANODE ONLY)	DISTANCE 'B' ANODE SPACING
100 mm	9 METRES	23 METRES
150 mm	6 METRES	15 METRES
200 mm	4 METRES	11 METRES
300 mm	3 METRES	8 METRES

NOTES:

- 1)* BOND CABLES ONLY REQUIRED IF BOTH PIPES ARE DUCTILE IRON.
- 2) TESTING, SPACING AS PER TS 7.20.

All dimensions are in millimetres unless otherwise shown.



ENGINEERING AND CONSTRUCTION SERVICES STANDARD DRAWING

REV 2

APR 2013

CATHODIC PROTECTION
SHORT SECTIONS OF DUCTILE IRON WATER MAINS

T-1106.06

NTS

SHEET 1