

PLAN

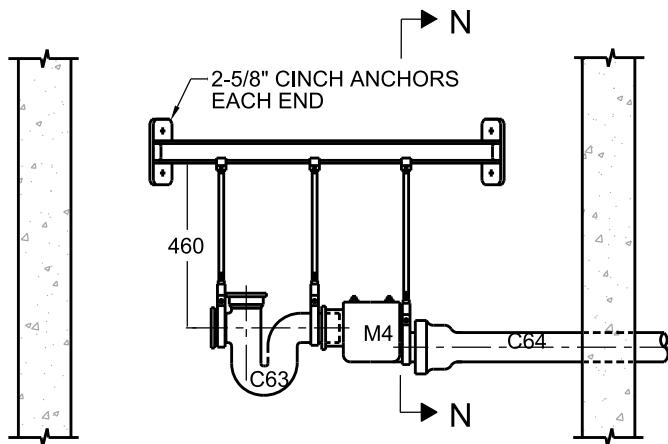

ELEVATION

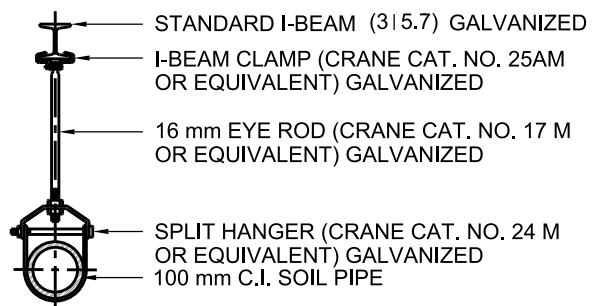

SECTION N

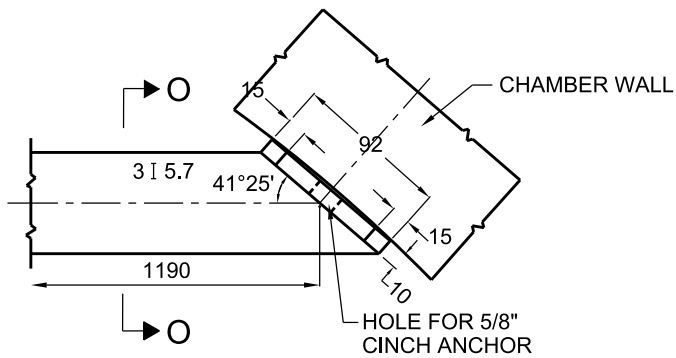

DETAIL 1
(PLAN VIEW)

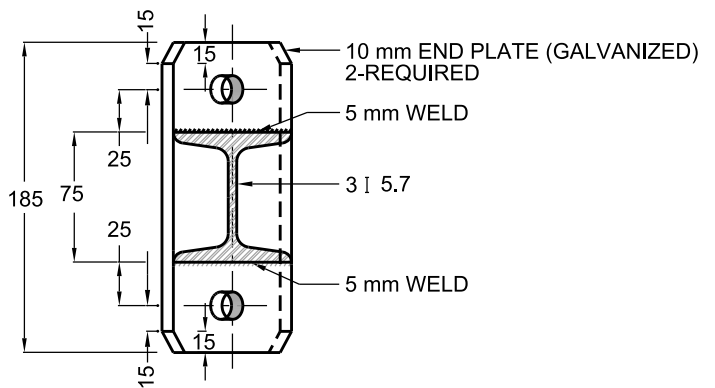

SECTION O

100 mm DRAIN - TYPE 'C'

All dimensions are in millimetres unless otherwise shown.



ENGINEERING AND CONSTRUCTION SERVICES STANDARD DRAWING

REV 1

APR 2013

SUMP AND DRAIN DETAILS
FOR PRECAST CHAMBERS

T-1102.01-4

NTS

SHEET 1