

ELEVATION

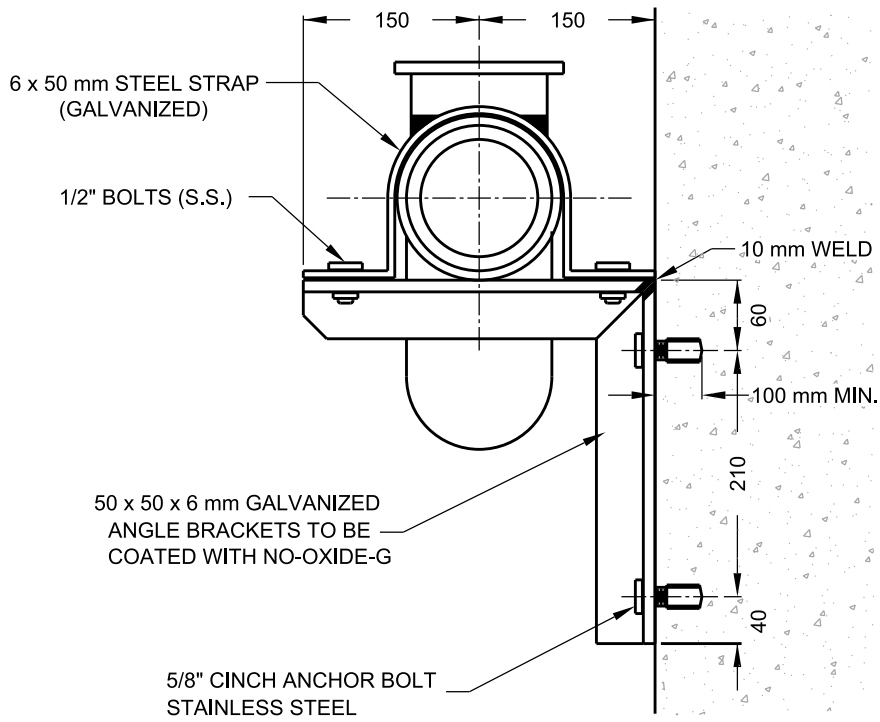

SECTION M-M

100 mm DRAIN - TYPE 'C'

All dimensions are in millimetres unless otherwise shown.



ENGINEERING AND CONSTRUCTION SERVICES STANDARD DRAWING

REV 1

APR 2013

SUMP AND DRAIN DETAILS
FOR POURED IN PLACE CHAMBERS

T-1102.01-7

NTS

SHEET 1