

EXTRA LOW VOLTAGE CABLE TO DETECTOR CABLE SPLICING DETAIL

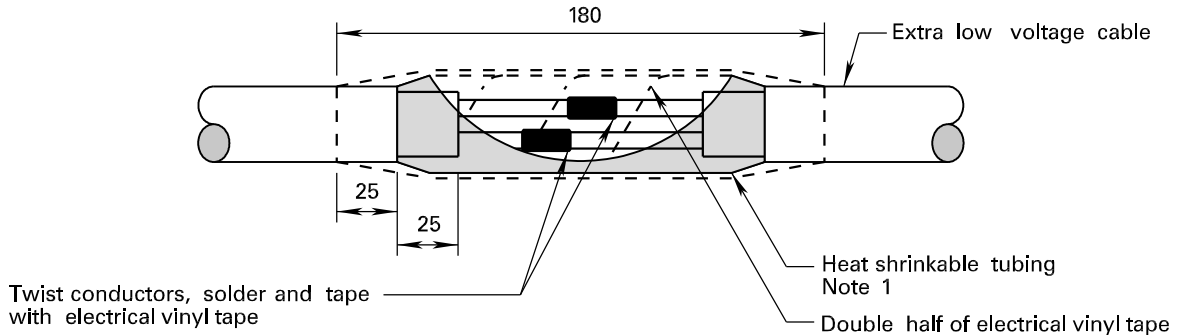

EXTRA LOW VOLTAGE CABLE-SPLICING DETAIL

NOTES

1. Heat shrinkable tubing to be 2.4 mm wall thickness, 19 mm dia., 600 volt.
2. Splice to be suitable dia. and length, and installed in accordance with manufacturer's instructions.

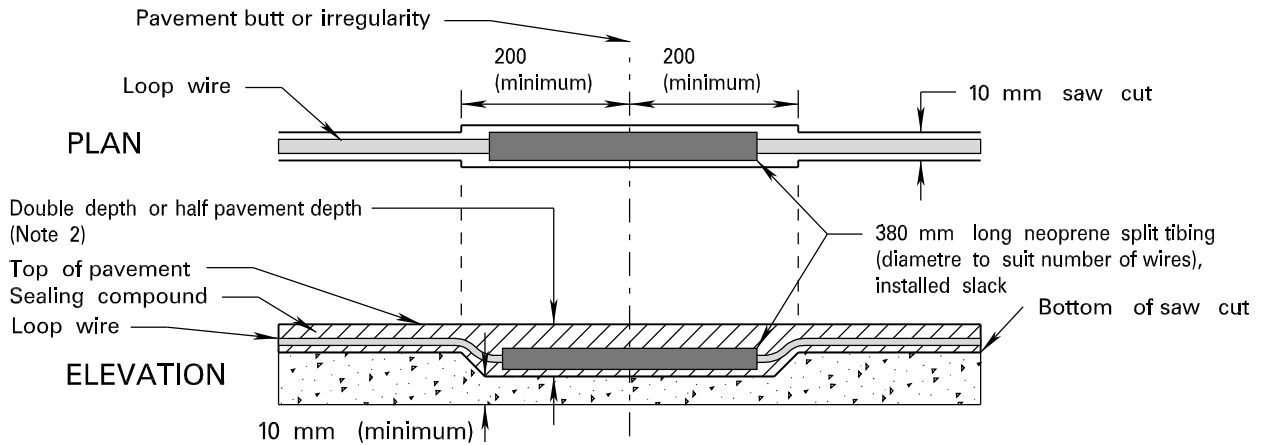

LOOP CROSSINGS OF ROAD CRACKS AND STREETCAR RAILS DETAIL

NOTES

1. Wiring to be installed to allow for expansion and contraction. Nicking or rubbing of cables on exposed sharp aggregates shall be avoided.
2. Depth of slot is determined by the number of turns required.
3. Slots to be cleaned by air blast, prior to installing wiring.