

VALVE SETTING FOR CONCRETE PRESSURE PIPE

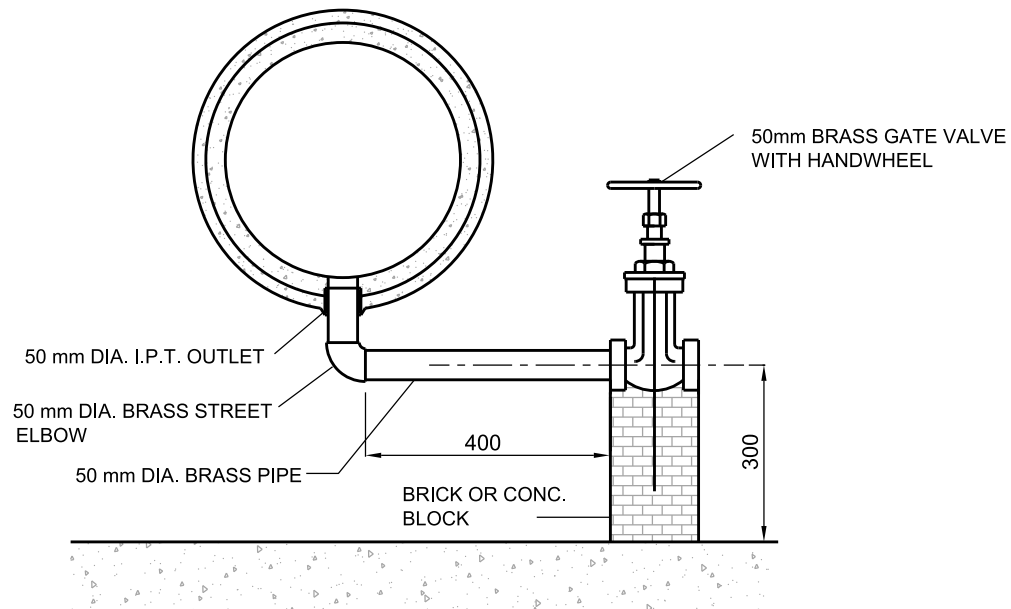

DRAIN DETAIL FOR CONCRETE WATERMAIN

All dimensions are in millimetres unless otherwise shown.



ENGINEERING AND CONSTRUCTION SERVICES STANDARD DRAWING

REV 1

APR 2013

VALVE SETTINGS FOR CONCRETE
PRESSURE PIPE
FOR 350 mm to 600 mm DIA. WATERMAIN

T-1101.030-5

NTS

SHEET 1