

THROUGH STREET
CURB CUT AND SIDEWALK RAMP AT LOCAL STREETS

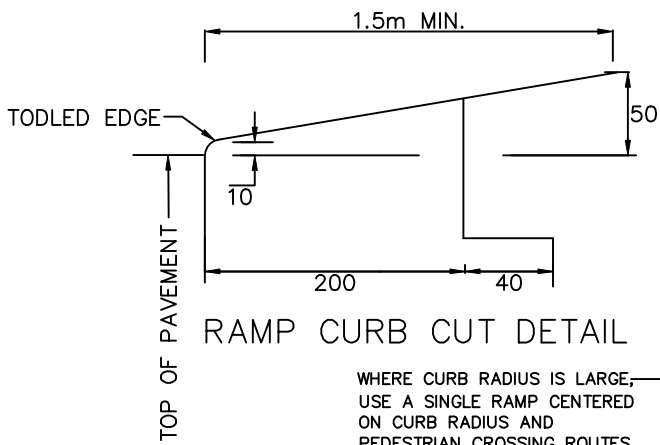

RAMP CURB CUT DETAIL

WHERE CURB RADIUS IS LARGE, USE A SINGLE RAMP CENTERED ON CURB RADIUS AND PEDESTRIAN CROSSING ROUTES.

WHERE CURB RADIUS IS SHORT OR SIDEWALK IS WIDE, TWO RAMP CENTERED ON PEDESTRIAN CROSSING ROUTES MAY BE REQUIRED.

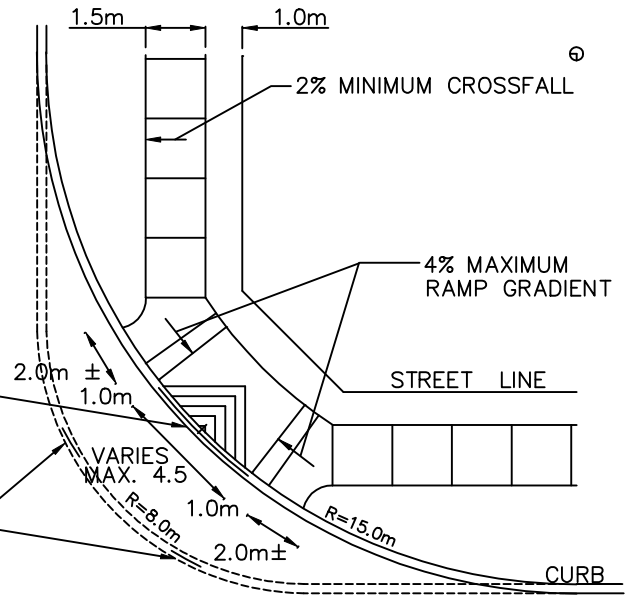

CURB CUT AND SIDEWALK RAMP AT MAJOR FOUR-WAY STOP OR SIGNAL CONTROLLED INTERSECTIONS

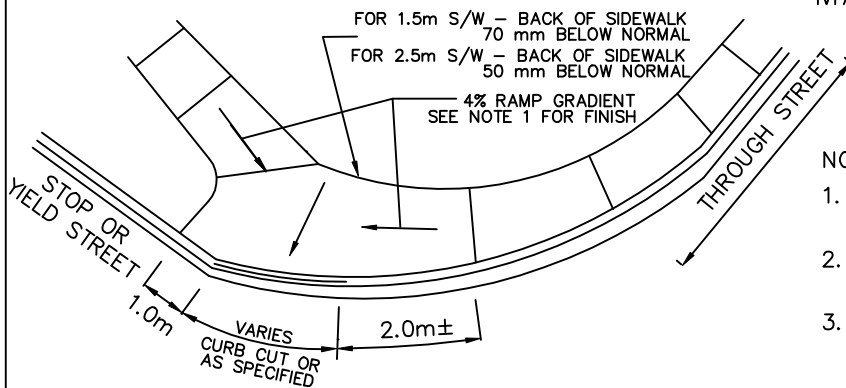

TYPICAL VIEW OF SIDEWALK RAMP

NOTES

1. RAMPS SHALL HAVE A COARSE TEXTURED BROOM FINISH.
2. SIDEWALK RAMP SHALL BE PROVIDED AT ALL INTERSECTIONS AND PEDESTRIANS CROSSWALKS.
3. RAMP GRADIENT IN EXCESS OF 4% SUBJECT TO APPROVAL AND IN NO CASE SHALL EXCEED 6%.

METRIC
ALL DIMENSIONS SHOWN HERE ARE IN MILLIMETRES UNLESS OTHERWISE NOTED

APPROVED BY
TOM DENES, P. ENG.
EXECUTIVE DIRECTOR TECHNICAL SERVICES

SCALE
N.T.S.

DATE: JUNE, 2001

REVISED:

STANDARD No.

T-310.020



CURB CUT AND SIDEWALK RAMP AT INTERSECTIONS