

FOR USE WITH RIGID PAVEMENT

2-15mm REINFORCING BARS FOR INDUSTRIAL DRIVEWAYS, TO BE EXTENDED 600mm BEYOND WIDTH OF DRIVEWAY ON EACH END.

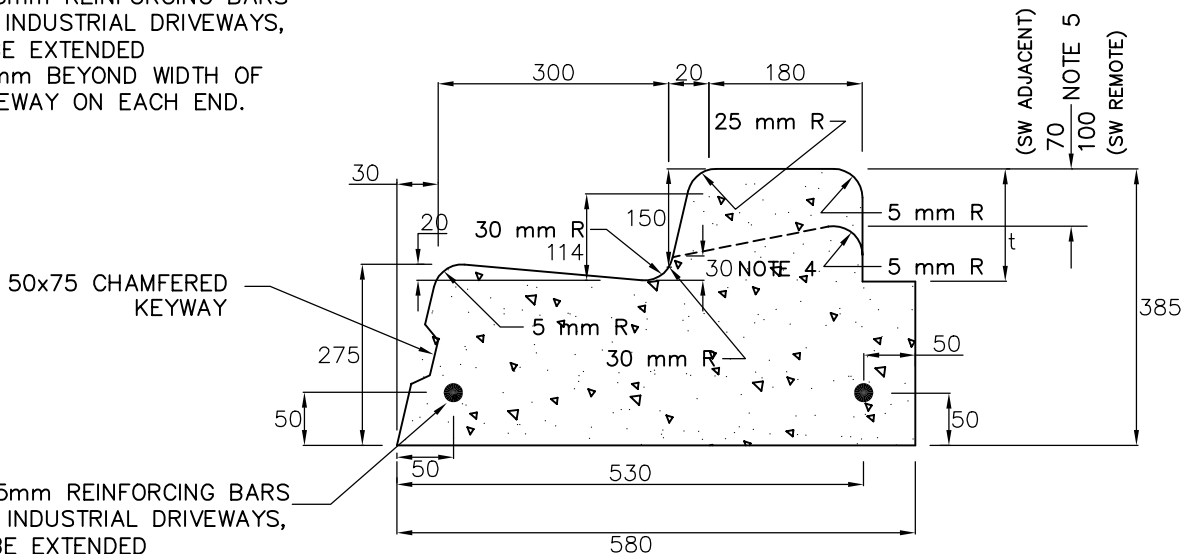

FOR USE WITH FLEXIBLE PAVEMENT

NOTES:

1. CONCRETE CURB MUST MATCH CONCRETE ROAD BASE
2. EXPANSION JOINTS SHALL BE SPACED 6 m APART TO COINCIDE WITH JOINTS IN ADJACENT SIDEWALK AND CONCRETE ROAD BASE.
3. t=THICKNESS OF ADJACENT SIDEWALK OR PAVER STRIP.
4. 10mm FOR SIDEWALK RAMPS AND DISABILITY ACCESSSES.
5. ENTRANCE TERMINATION AS PER DWG. T-350.01

METRIC
ALL DIMENSIONS SHOWN HERE ARE IN MILLIMETRES UNLESS OTHERWISE NOTED



WORKS & EMERGENCY SERVICES

TECHNICAL SERVICES DIVISION
Engineering Services - Works Facilities & Structures

CONCRETE CURB AND GUTTER

SCALE:

N.T.S.

DATE:

DECEMBER, 2003

DRAFTING:

V. DIDIANO

DRAWING NUMBER:

T-600.05-1

SHEET:

1