

FOR USE WITH RIGID PAVEMENT

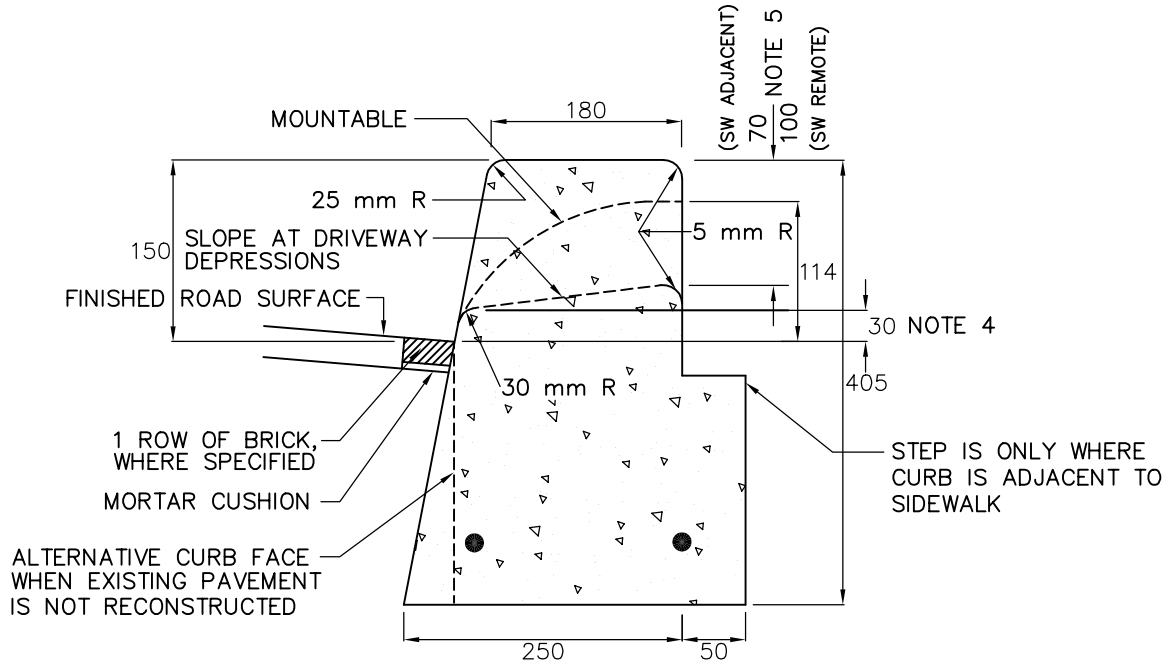

FOR USE WITH FLEXIBLE PAVEMENT

NOTES:

1. EXPANSION JOINTS SHALL BE SPACED 6 m APART TO COINCIDE WITH JOINTS IN ADJACENT SIDEWALK AND CONCRETE ROAD BASE.
2. t = THICKNESS OF ADJACENT SIDEWALK OR PAVER STRIP.
3. 10mm FOR SIDEWALK RAMPS AND DISABILITY ACCESSSES.
4. ENTRANCE TERMINATION AS PER DWG. T-350.01

METRIC
ALL DIMENSIONS SHOWN HERE ARE IN MILLIMETRES UNLESS OTHERWISE NOTED



WORKS & EMERGENCY SERVICES

TECHNICAL SERVICES DIVISION
Engineering Services - Works Facilities & Structures

CONCRETE CURB

SCALE:

N.T.S.

DATE:

DECEMBER, 2003

DRAFTING:

V. DIDIANO

DRAWING NUMBER:

T-600.11-1

SHEET:

1