

ISOLATION WITHIN THE SLAB

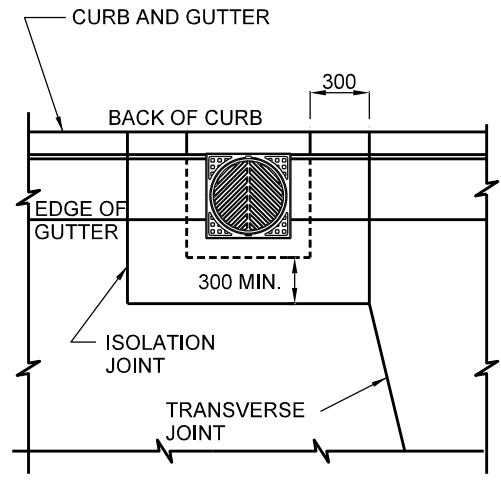

ISOLATION ADJACENT TO CURB

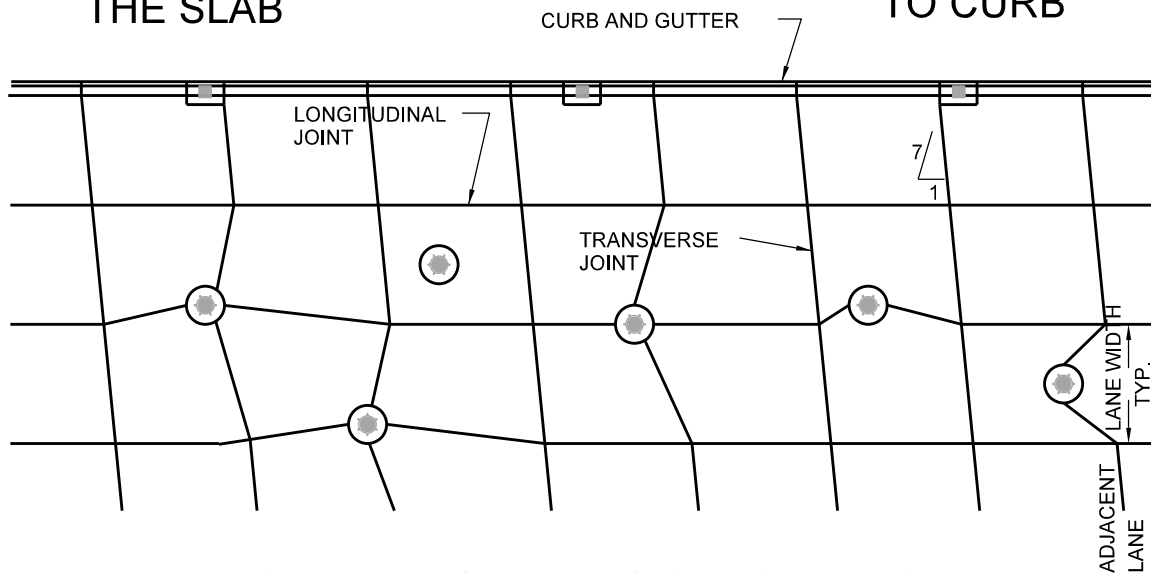

TYPICAL ADJUSTMENTS OF JOINTING AT UTILITY ISOLATION

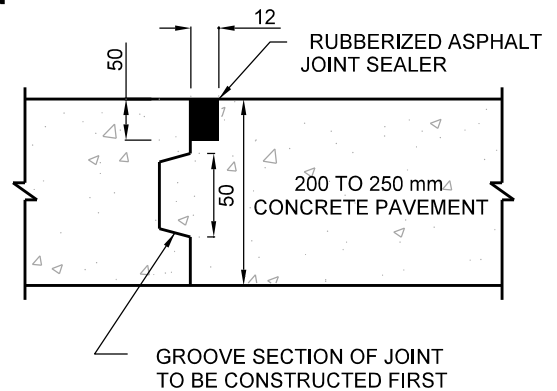

ISOLATION JOINT

NOTES:

1. WHEN LONGITUDINAL JOINT OR TRANSVERSE JOINT IS WITHIN 1 m OF THE ISOLATION JOINT, USE APPROPRIATE ADJUSTMENT OF JOINTING.

All dimensions are in millimetres unless otherwise shown.



ENGINEERING & CONSTRUCTION SERVICES STANDARD DRAWING

REV 1

NOV 2014

**UTILITY ISOLATION
IN COMPOSITE PAVEMENT**

T-216.02-5

NTS

SHEET 1