

## CONCRETE SIDEWALK WITH SOFT BOULEVARD

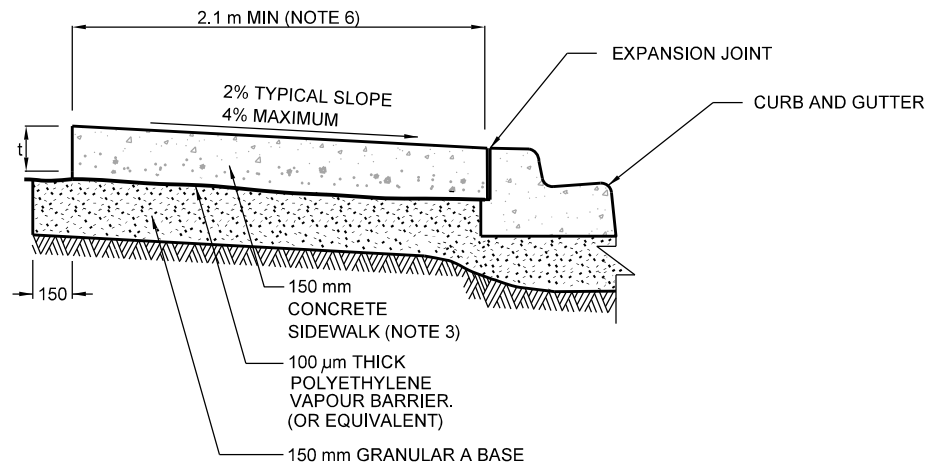

## CONCRETE SIDEWALK ADJACENT TO CURB AND GUTTER

### NOTES:

1. FOR CONCRETE SIDEWALK ABUTTING CURB OR CURB AND GUTTER REFER TO T-600.05-1 AND T-600.11-1.
2. SIDEWALK THICKNESS 130 mm EXCEPT ACROSS COMMERCIAL, INDUSTRIAL AND HIGH DENSITY RESIDENTIAL DRIVEWAY WHERE THICKNESS SHALL BE 180 mm.
3. SIDEWALK THICKNESS 150 mm EXCEPT ACROSS COMMERCIAL, INDUSTRIAL AND HIGH DENSITY RESIDENTIAL DRIVEWAY WHERE THICKNESS SHALL BE 180 mm.
4. t = THICKNESS OF SIDEWALK.
5. JOINTS SHALL BE ACCORDING TO T-310.010-1.
6. ON LOCAL ROADS, THE MINIMUM SIDEWALK WIDTH CAN BE REDUCED TO 1.8 m, EXCEPT FOR NEW DEVELOPMENTS, WHICH MUST ADHERE TO THE TORONTO GREEN STANDARDS AND DIPS.

All dimensions are in millimetres unless otherwise shown.



ENGINEERING & CONSTRUCTION SERVICES STANDARD DRAWING

**CONCRETE SIDEWALK WITH SOFT BOULEVARD  
OR CONCRETE SIDEWALK ADJACENT TO CURB**

REV 4

SEP 2017

**T-310.010-2**

NTS

SHEET 1