

SECTION A-A

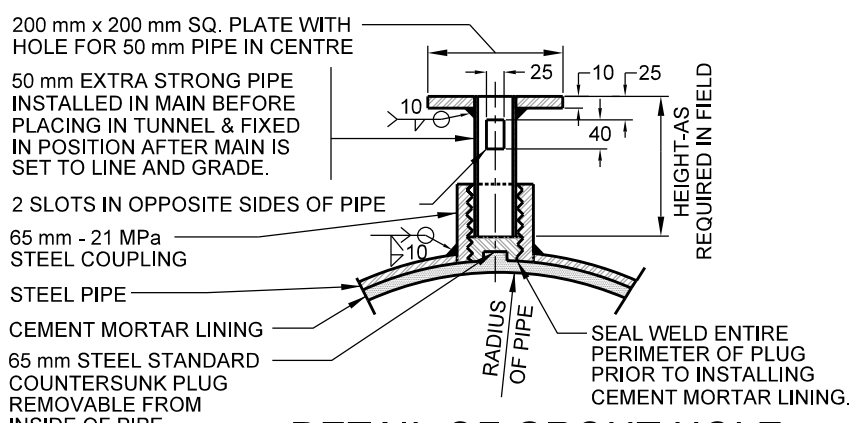

**DETAIL OF GROUT HOLE,
NOZZLE AND PLUG**

- NOTES:**
1. COUPLING, NOZZLE AND PLUG TO BE INSTALLED ON STEEL PIPE AT 3000 mm CENTRES, FOR FIXING PIPE FIRMLY IN TUNNEL AND GROUTING PURPOSES.
 2. IF COUNTERSUNK HEAD PLUGS ARE NOT AVAILABLE, SQUARE HEAD PLUGS MAY BE USED IF HEADS ARE CUT OFF FLUSH TO INSIDE OF STEEL PIPE BEFORE CEMENT MORTAR LINING IS APPLIED.

All dimensions are in millimetres unless otherwise shown.



ENGINEERING & CONSTRUCTION SERVICES STANDARD DRAWING

REV 0 APR 2017

**TUNNEL
RAILWAY CROSSING DETAIL
STEEL PIPE**

T-1110.05-3

NTS SHEET 1