

ALTERNATIVES
A PRECAST MONOLITHIC BASE

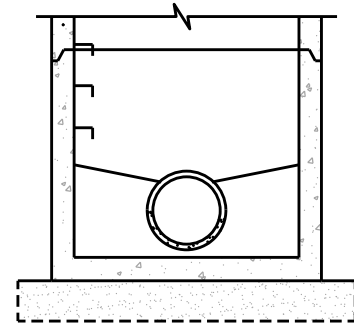

B CAST IN PLACE BASE

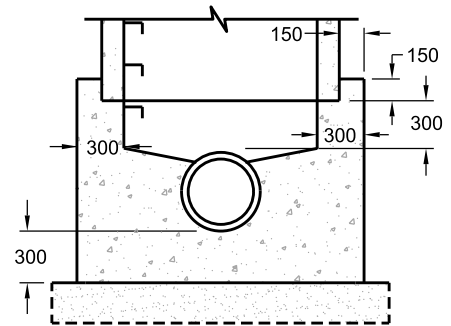

C TAPERED TRANSITION SLAB

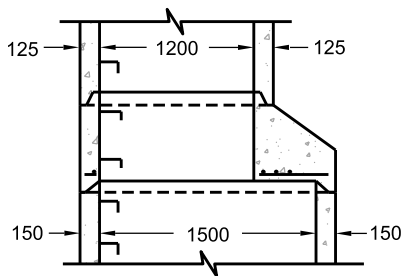

D 1200 mm PRECAST FLAT CAP

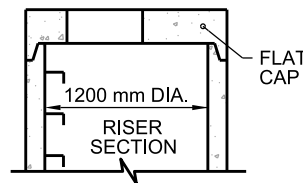

E 1500 mm PRECAST FLAT CAP

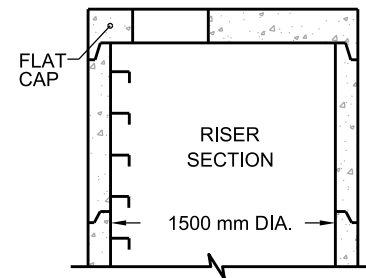

NOTES:

1. FOR SUMP DETAIL SEE T-701.010.
2. 150mm OF COMPACTED 20 mm CRUSHED STONE OR UNSHRINKABLE FILL TO BE PLACED ALL AROUND THE MAINTENANCE HOLE.
3. PRECAST CONCRETE COMPONENTS ACCORDING TO OPSD 701.040, OPSD 703.011 AND OPSD 703.021.
4. STRUCTURES EXCEEDING 5.0m IN DEPTH TO INCLUDE SAFETY PLATFORM ACCORDING TO OPSD 404.020.
5. PIPE SUPPORT ACCORDING TO T-708.020.

All dimensions are in millimetres unless otherwise shown.

6. FOR BENCHING DETAILS, MAXIMUM PIPE HOLE DIAMETERS AND FLOW CONFIGURATIONS, SEE T-701.021.
7. PARGING SHALL BE 1:3 MORTAR MIX.
8. WATERPROOFING OVER PARGING TO BE TWO HEAVY COATS OF BITUMEN.
9. WHERE PIPES JOIN AT MANHOLE, JOINTS ARE TO BE WATERTIGHT WITH THE APPROVED SEAL.
10. ALL DIMENSIONS ARE NOMINAL.
11. FIRST STEP TO BE 75 mm TO 300 mm BELOW FRAME LAST STEP TO BE 300 mm ABOVE BENCHING OR 600 mm ABOVE INVERT IF NO BENCHING.



ENGINEERING AND CONSTRUCTION SERVICES STANDARD DRAWING

REV 2

APR 2013

PRECAST MAINTENANCE HOLE
1500 mm DIAMETER

T-701.011

NTS

SHEET 1