

CROSS SECTION

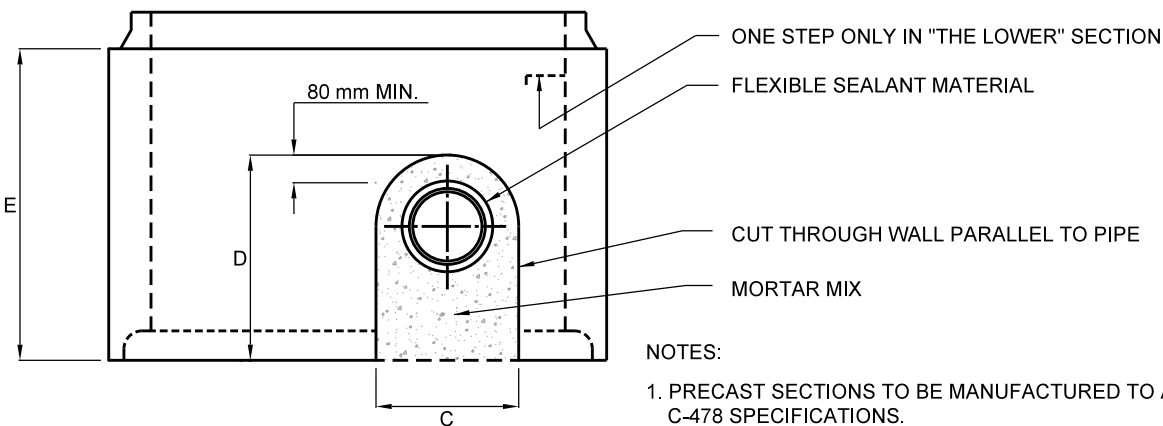

WALL OPENING DETAIL

NOTES:

1. PRECAST SECTIONS TO BE MANUFACTURED TO A.S.T.M. C-478 SPECIFICATIONS.
2. BASE AND VALVE SUPPORT CONCRETE STRENGTH 20 MPa.
3. ALL MORTAR MIX TO BE 1:3.
4. ALL JOINTS AND LIFT HOLES IN CHAMBER SECTIONS TO BE FILLED WITH MORTAR AND POINTED BEFORE BACKFILLING.
5. ALUMINUM STEPS AS PER OPSD 405.020 AT 300 mm C.C. (FIRST STEP 75 mm BELOW FRAME).
6. POLYETHYLENE BOND BREAKER TO BE USED BETWEEN CONCRETE AND FITTINGS.
7. ALL BRICKWORK (EXTERIOR) TO BE PARGED -15 mm MIN.
8. CONCRETE VALVE SUPPORT ON 400 mm VALVES TO BE MODIFIED TO CLEAR SPINDLE RETAINING NUTS OR SCOUR PLUGS.
9. ON 400 mm VALVES ACCESSIBILITY INTO CHAMBERS HAS PRIORITY OVER ADJUSTMENT PARAMETERS.
10. VALVE TIE DOWNS TO BE USED WITH P.V.C. PIPE ONLY.

DIMENSION	100 mm - 250 mm WATERMAIN	300 mm - 400 mm WATERMAIN
A	1200	1500
B	127	150
C	400	550
D	600	750
E	900	1050
F	400	550
G	200	300
H	200	300

All dimensions are in millimetres unless otherwise shown.



ENGINEERING AND CONSTRUCTION SERVICES STANDARD DRAWING

**CIRCULAR PRECAST VALVE CHAMBER
400 mm DIAMETER WATERMANS AND SMALLER**

REV 1

APR 2013

T-1101.010

NTS

SHEET 1