

TYPE A

OPENING DIMENSIONS mm			
GRATE TYPE	SLOPE	A	B
		B	2:1
3:1	632		71
4:1	618		78
HOR	600		87

FRONT VIEW

SECTION

A

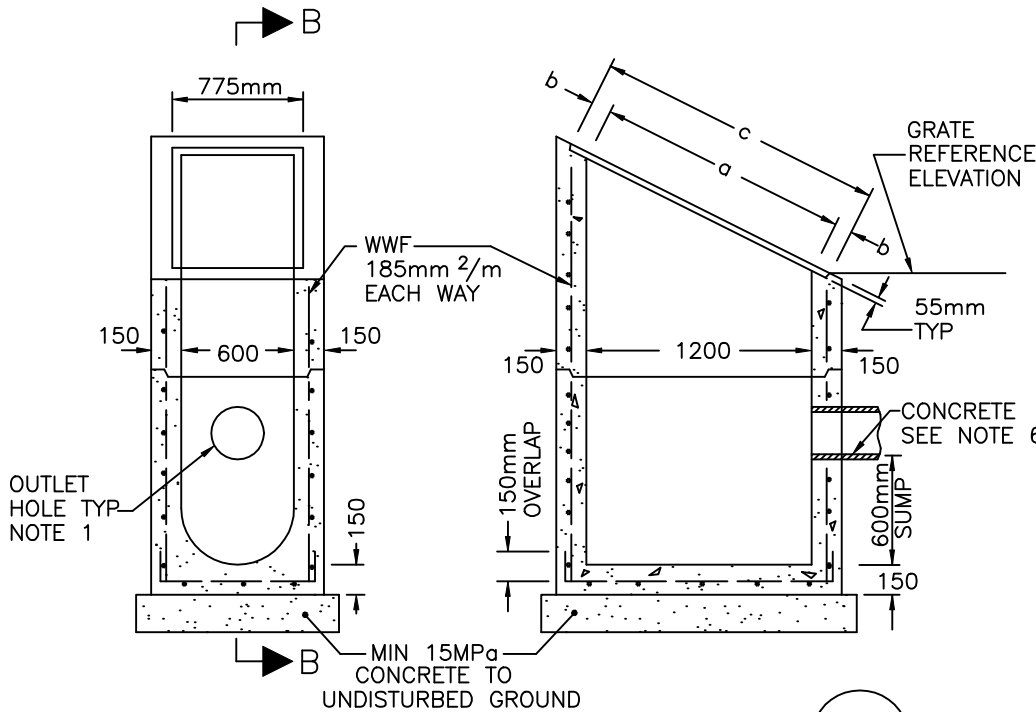

TYPE B

OPENING DIMENSIONS mm				
GRATE TYPE	SLOPE	a	b	c
		C	2:1	1341
3:1	1265		104	1473
4:1	1237		118	1473
B	6:1	1216	65	1346
	8:1	1210	68	1346
	10:1	1206	70	1346
	HOR	1200	73	1346

FRONT VIEW

SECTION

B

NOTES:

- 1 OUTLET HOLE SIZE 525mm MAX DIA ALONG NARROW WALL AND 1000mm ALONG WIDE WALL.
- 2 WHERE INLET IS PLACED ACROSS DITCH AND IS ACCESSIBLE TO VEHICULAR TRAFFIC, GRATING SLOPE IS TO BE 6:1 OR FLATTER.
- 3 ALL REINFORCING STEEL SHALL HAVE 25mm MIN. COVER.
- 4 GRATING ACCORDING TO T-403.01.
- 5 PIPE SUPPORT ACCORDING TO T-708.020.
- 6 ALL DIMENSIONS ARE NOMINAL.
- 7 ALL DIMENSIONS ARE IN MILLIMETERS OR METERS UNLESS OTHERWISE SHOWN.

METRIC
 ALL DIMENSIONS SHOWN HERE ARE IN MILLIMETERS UNLESS OTHERWISE NOTED

APPROVED BY *[Signature]*
 TOM DENES, P. ENG.
 EXECUTIVE DIRECTOR TECHNICAL SERVICES

SCALE
 N.T.S.



PRECAST CONCRETE CATCHBASIN DITCH INLETS
 600mm x 1200mm x DEPTH 4.0m MAX.

DATE: JUNE, 2001
 REVISED:
 STANDARD No.
 T-705.040