

CONNECTION WITH CROSS

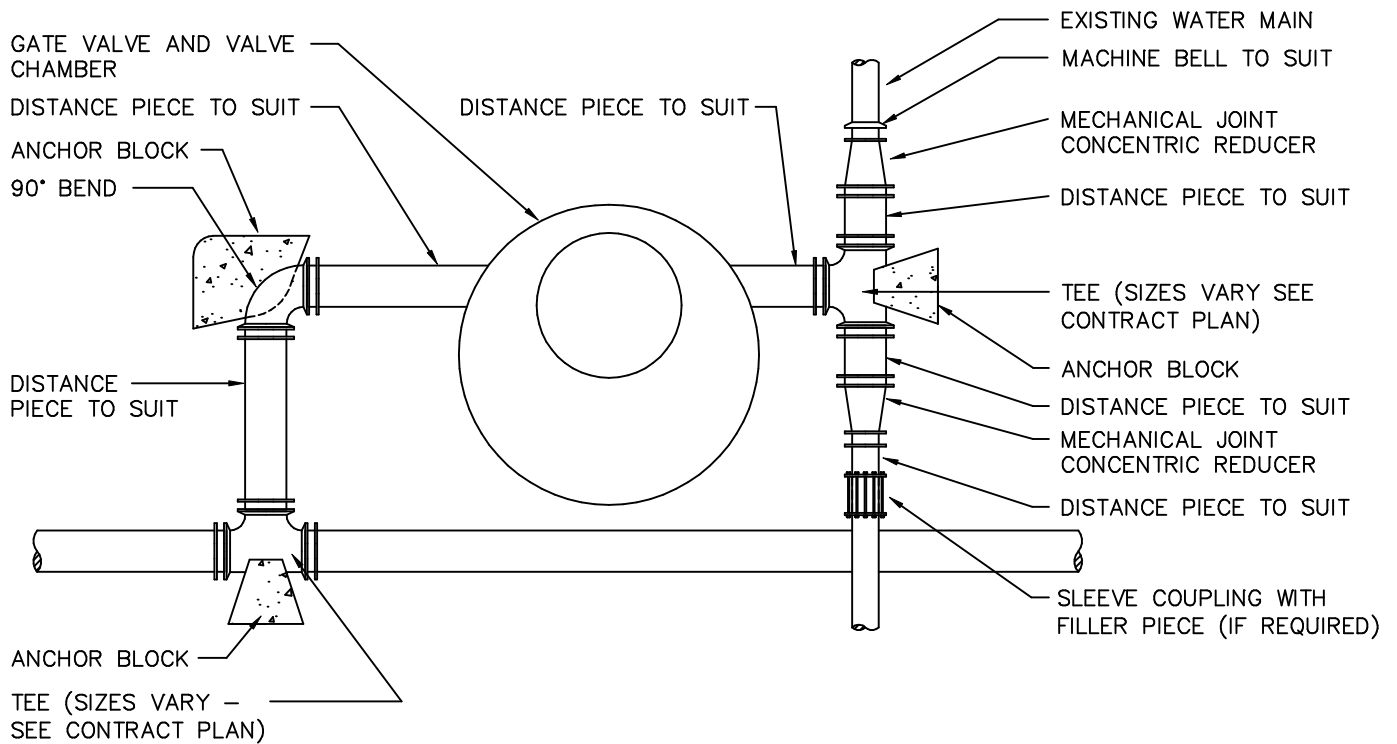

CONNECTION WITH TEE

NOTES:

THE CONTRACTOR MAY AT HIS OWN DISCRETION OMIT THE SLEEVE COUPLINGS IF HE IS ABLE TO MAKE SATISFACTORY CONNECTIONS WITHOUT THEM. HIS ATTENTION IS ALSO DIRECTED TO THE POSSIBILITY OF THE EXISTING PIPE BEING OVERSIZED.

METRIC
ALL DIMENSIONS SHOWN HERE ARE IN MILLIMETRES UNLESS OTHERWISE NOTED

APPROVED BY

Tom Denes
TOM DENES, P. ENG.
EXECUTIVE DIRECTOR TECHNICAL SERVICES

SCALE

N.T.S.

DATE: JUNE, 2001

REVISED:

STANDARD No.

T-1107.04-3