

**DETAIL OF MOUNTING PLATE**

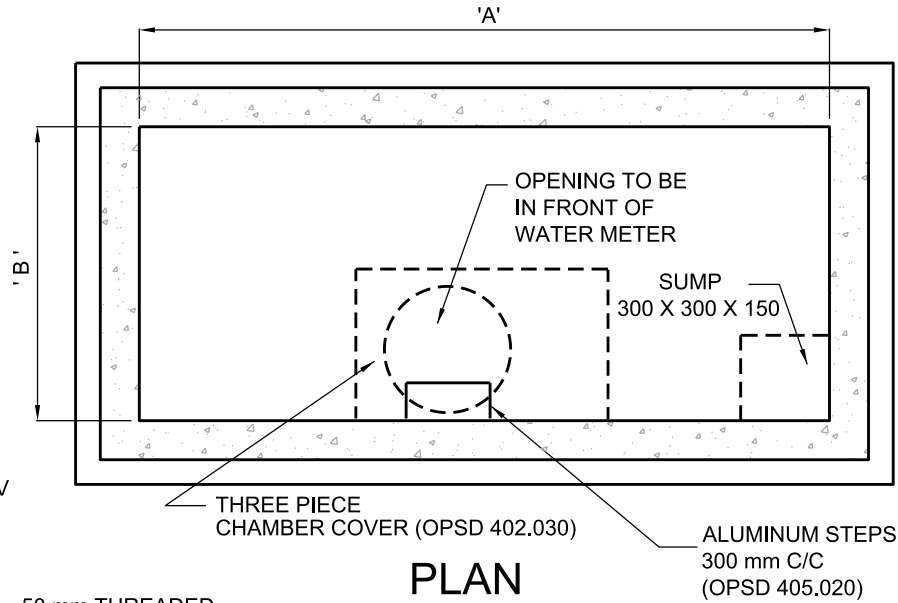

**PLAN**

FLANGE THREADED IN PLACE

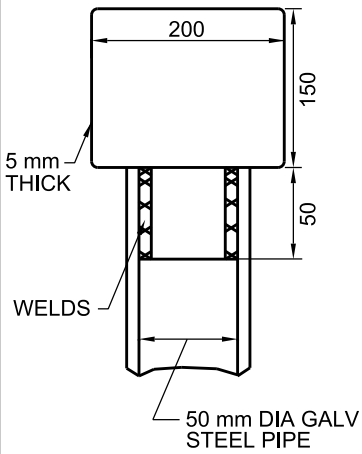
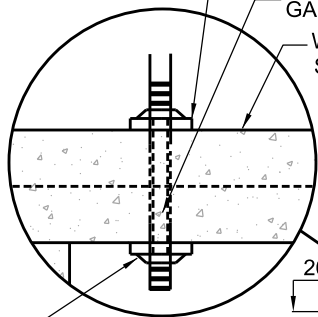

**DETAIL**

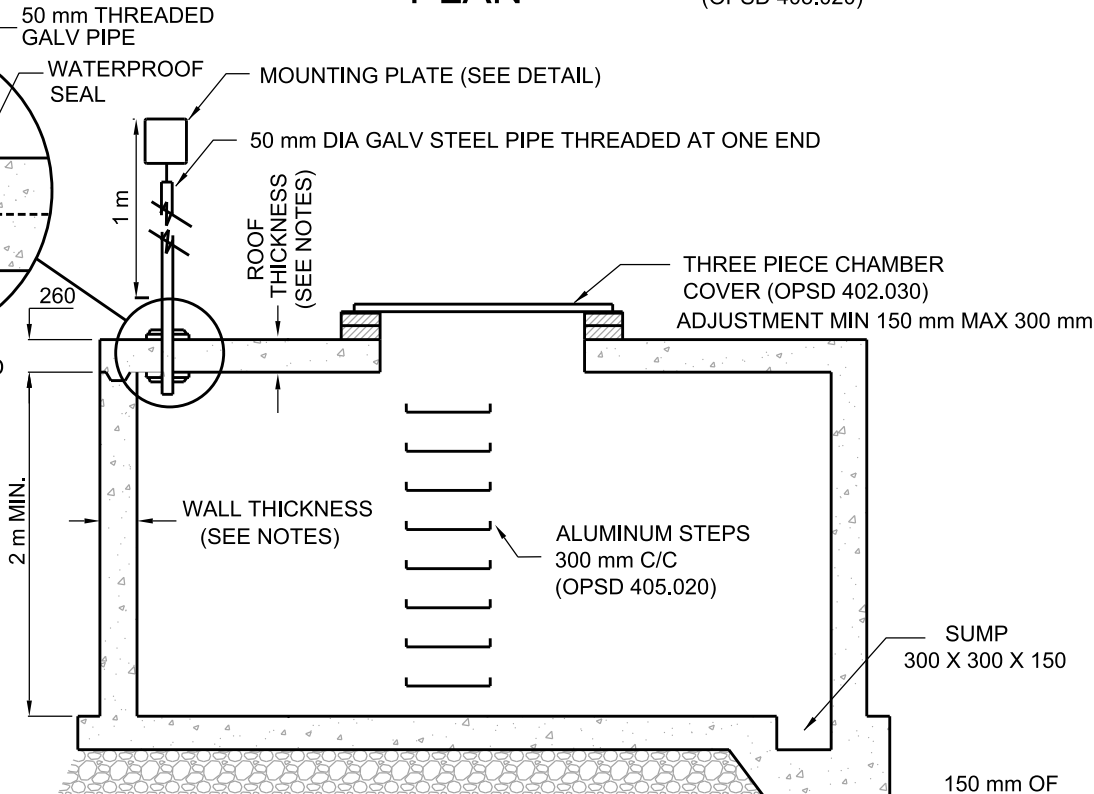

**ELEVATION**

PIPE SIZE	MINIMUM INTERIOR DIMENSIONS	
	A (m)	B (m)
75 mm AND 100 mm	3.5	2.3
150 mm	4.3	2.5
200 mm	5.0	2.7
250 mm	6.0	3.0
300 mm	6.6	3.2
GREATER THAN 300 mm	DESIGNED TO SUIT	

NOTES ON T-1108.01-1 SHEET 2 ARE INTERGRAL PART OF THIS DRAWING

All dimensions are in millimetres unless otherwise shown.



ENGINEERING AND CONSTRUCTION SERVICES STANDARD DRAWING

**WATER METER CHAMBER FOR  
75 mm OR GREATER  
PRIVATE WATER SERVICE PIPE**

REV 3	APR 2013
<b>T-1108.01-1</b>	
NTS	SH 1 of 2

Notes :

1. Concrete strength shall be 35 MPa with 6% air entrainment.
2. Reinforcing bars to have a minimum of 50 mm concrete cover.
3. Precast sections to be as per OPSS 1351.
4. Base concrete strength shall not be less than 30 MPa.
5. All mortar mix to be 1:3.
6. All joints and lift holes in chamber sections to be filled with mortar and pointed before backfilling.
7. Solid aluminum steps as per OPSD 405.020 at 300 mm centre to centre with first step to be 300 mm below frame.
8. Polyethylene bond breaker to be used between concrete and fittings. An approved flexible sealant shall be used where the pipe goes through the chamber wall. Installation of pipe seal shall conform to manufacturer's directions.
9. All exterior and interior brickwork and frame adjustment rings to be parged to a minimum 15 mm thickness.
10. Floor to slope to sump. Sump to be positioned in either corner on the front side of the water meter.
11. Circular cover in three piece frame and cover shall be positioned immediately adjacent to the wall in front of the meter directly over the 900 mm clear space in front of the meter.
12. Reinforced concrete design shall be adequate for chamber dimensions shown under H-20 loading.
13. The words "Water Meter" shall be cast onto the surface of the chamber cover using minimum 50 mm high letters.
14. The three piece chamber frame and cover shall be as per OPSD 402.030.
15. No other piping or fittings shall be installed in the chamber that may interfere with the clear space in front of the water meter or the operation of valves or that may obstruct the meter or valves in any way.

All dimensions are in millimetres unless otherwise shown.

	ENGINEERING AND CONSTRUCTION SERVICES STANDARD DRAWING	REV 3	APR 2013
	<b>WATER METER CHAMBER FOR 75 mm OR GREATER PRIVATE WATER SERVICE PIPE</b>	<b>T-1108.01-1</b>	
		NTS	SH 2 of 2