

PLAN

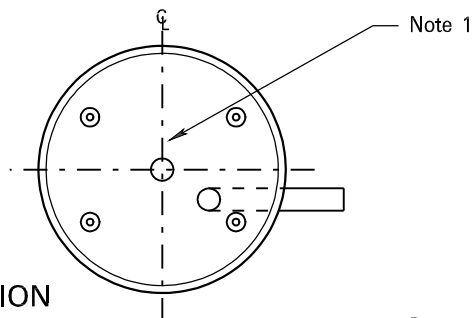

ELEVATION

TYPE 1

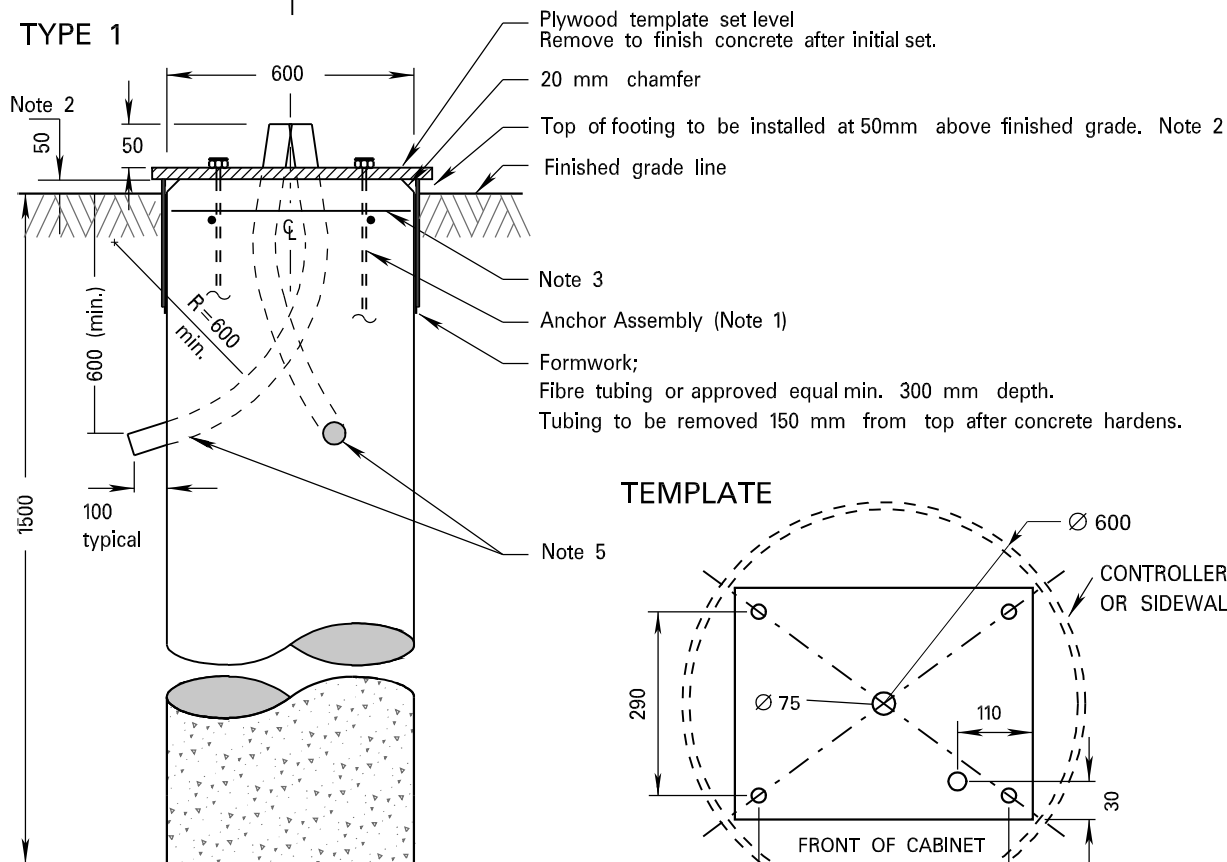

TEMPLATE

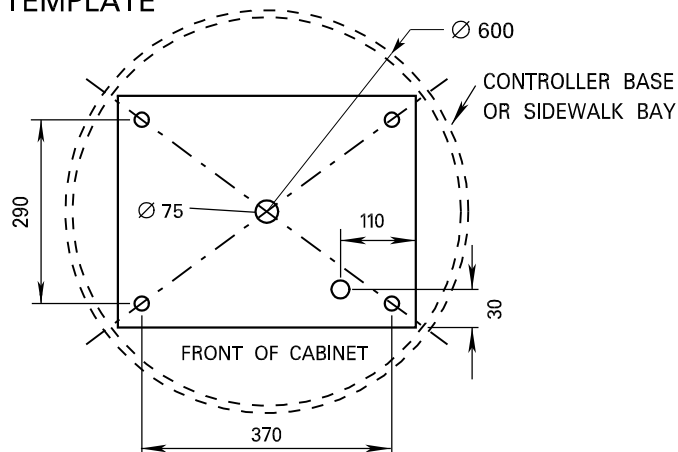

NOTES

1. For base mounting details, anchor assembly, template details and cabinet orientation see standard TTD 807.020. For duct orientation and size refer to layout drawing.
 2. Top of footing to be installed at 50mm above finished grade.
 3. For more than 2 ducts, provide wire mesh 6mm dia., 100 x 100mm, 150mm from top of controller footing.
 4. Concrete base shall be level.
 5. Solvent weld caps (scepter or equal) of the proper size shall be placed on ends of all unused rigid PVC conduit.
 6. Anchor bolts installed in locations according to cabinet manufacturer's layout drawing.
- Dimensions are in millimetres or metres, unless otherwise shown.