

NOTES

- 1 For installation of ducts see standard TTD 802.025
- 2 Cover to be retained with 2-12mm dia. x 20 mm long stainless steel hex head machine bolts, to be flush with top of cover when fastened.
- 3 Material for frame and cover-ASTM A48 / A48m-03 gray iron casting class No. 30C
- 4 Frame to be attached using 3 - 10mm dia. x 38mm long machine bolts anchored in concrete wall.
- 5 9.5mm dia. x 38mm machine bolt anchored in concrete, 40mm x 12mm slot cut in fibre at each bolt location to allow for vertical adjustment of casing.
- 6 19mm clean crushed rock to be installed under handwell for drainage. For general installation details refer to standard TTD 802.010.

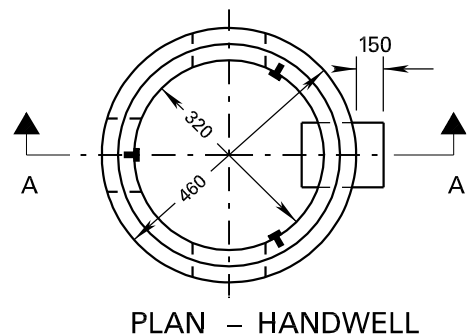
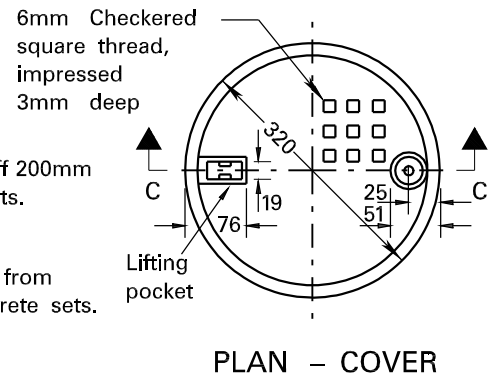
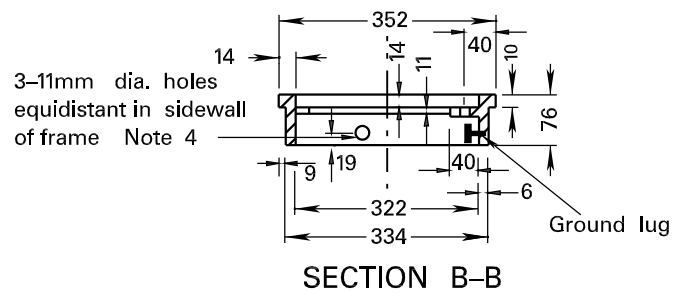

SECTION A-A

Dimensions are in millimetres or metres, unless otherwise shown.