

UNDERSIDE OF COVER

SECTION B-B

PLAN - FRAME

NOTES

- 1 For installation of ducts see standard 802.025
- 2 Cover to be retained with 2-12 mm dia. x 20mm long stainless steel hex head machine bolts, to be flush with top of cover when fastened.
- 3 Material for frame and cover-ASTM A48/ A48m-03 gray iron casting class No. 30C
- 4 Frame to be attached using 3 - 10mm dia. x 38mm long machine bolts anchored in concrete wall
- 5 Lifting hooks to be removed after Handwell installation.
- 6 19 mm clean crushed rock to be installed under handwell for drainage. For general installation details refer to standard TTD 802.010.
- 7 Unshrinkable fill, to be placed around Handwell.

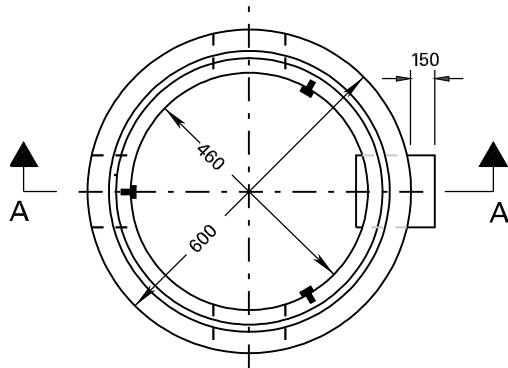

PLAN - HANDWELL

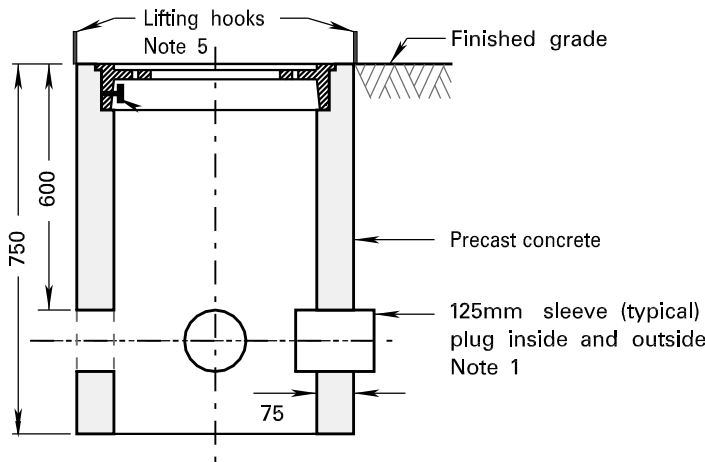

SECTION A-A

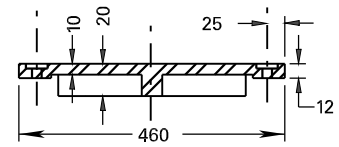

SECTION C-C

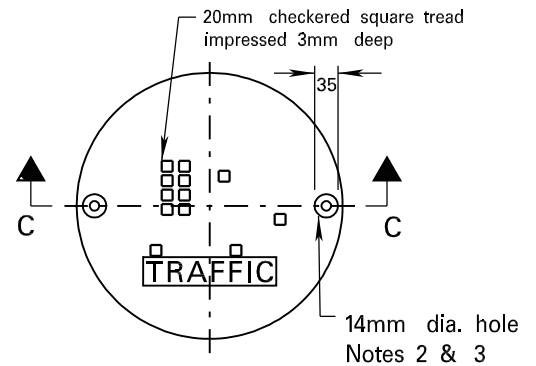

PLAN - COVER

Dimensions are in millimetres or metres, unless otherwise shown.