

METRIC
 ALL DIMENSIONS SHOWN HERE ARE IN
 MILLIMETRES UNLESS OTHERWISE NOTED

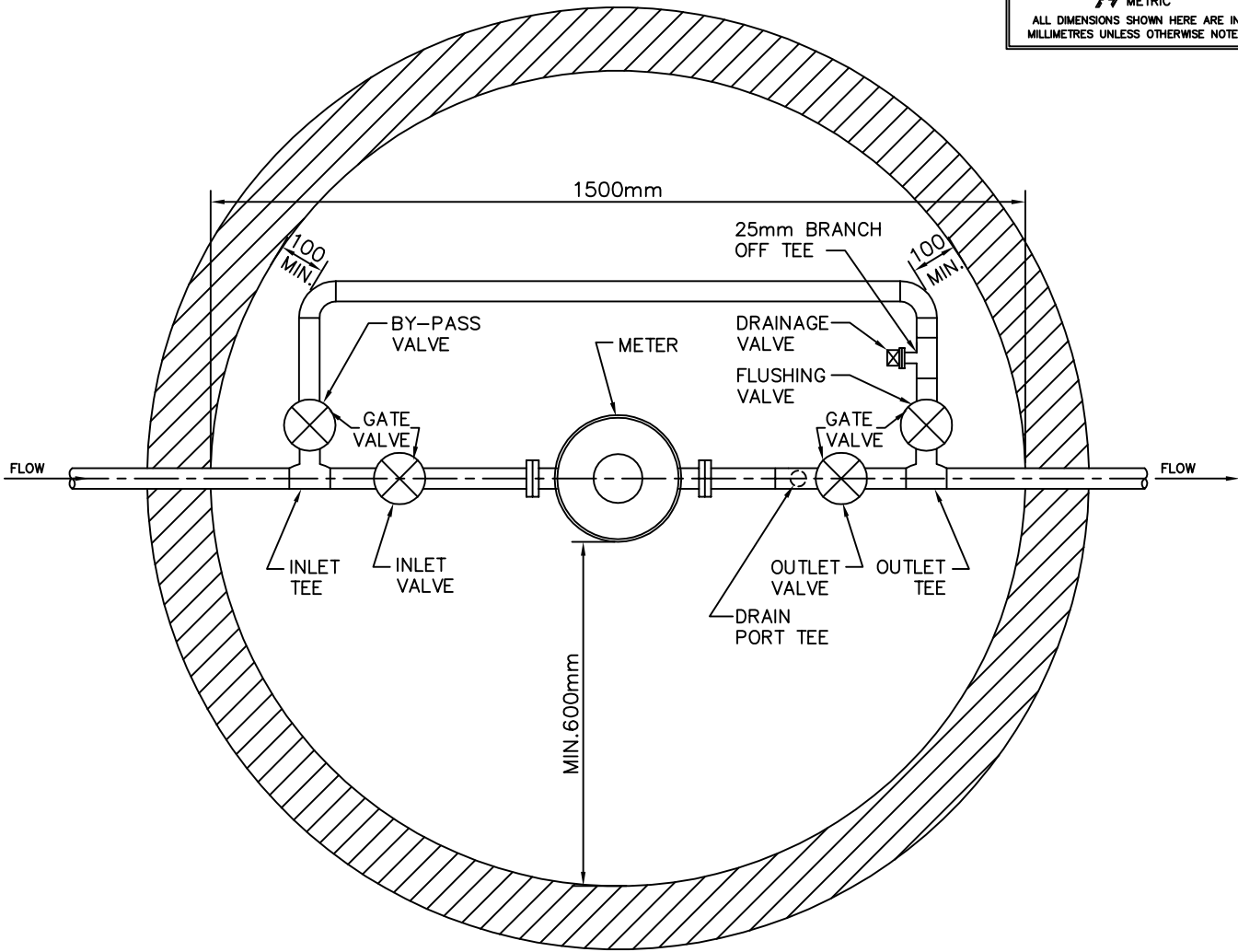

PLAN

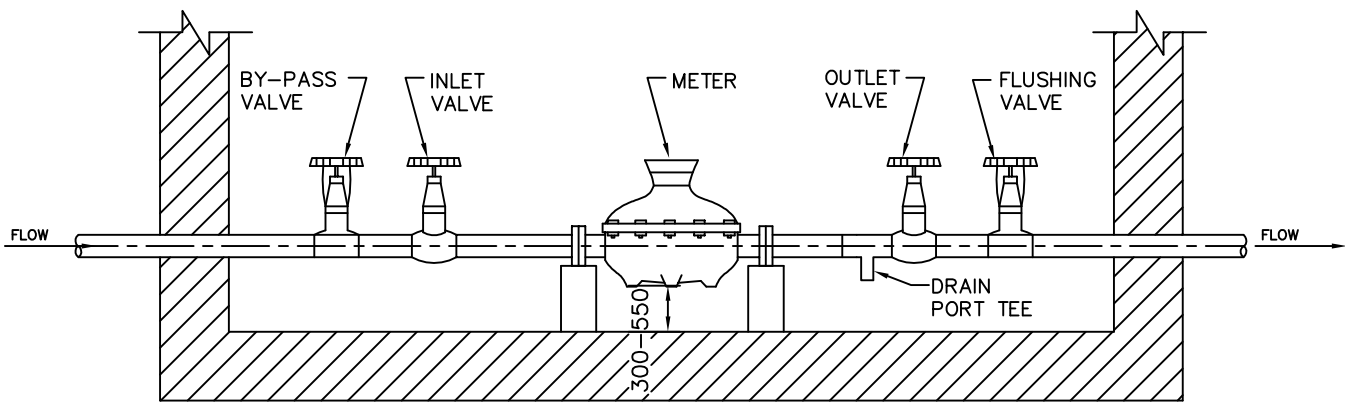

ELEVATION

NOTES ON T-1107.01-1 SHEET 2
 ARE INTERGRAL PART OF THIS
 DRAWING



TECHNICAL SERVICES
 Engineering Services - Works Facilities & Structures

SCALE:	N.T.S.	PIPING LAYOUT FOR METER CHAMBER UP TO 50 mm PRIVATE WATER SERVICE PIPE	DRAWING NUMBER:
DATE:	FEBRUARY 2006		T-1107.01-1
DRAFTING:	V.D. / L.B.-H.		SHEET: 1 of 2

Notes:

1. All water meters shall be installed in the horizontal position. By-pass piping shall be installed in the horizontal position around the water meter. The private water service pipe shall be installed through the horizontal centre of the chamber.
2. Water meters shall be installed with a minimum 600 mm unobstructed clearance in front of water meter to nearest wall.
3. By-pass piping shall be installed with a minimum 100 mm unobstructed clearance from the outside wall of the by-pass pipe to the nearest wall.
4. The working space in front of the meter shall have a minimum of 2.0 meters unobstructed head clearance.
5. All meters and piping shall be fully supported from the floor and such support shall be suitable for that purpose and shall be supplied and installed by the Owner at the time of the installation of the water meter
6. All valves, bends and tees shall be flanged, threaded or solder type. Acid core type solder not permitted
7. All piping, including by-pass pipe, tees, bends and valves, except for the tee on the drainage valve shall be the same diameter as the private water service pipe. Pipe reducers required to accommodate a smaller water meter than the private water service pipe shall only be installed between the inlet and outlet valves and shall be attached directly to the valves. All pipe reducers shall be concentric type reducers
8. From the time of the installation of the water meter, the by-pass and flushing valves shall remain closed at all times and shall be sealed by the City.
9. Only gate valves shall be permitted for inlet, outlet, by-pass or flushing valves. No ball valves or butterfly valves shall be permitted. Valves shall be designed for a minimum cold water working pressure of 1,035 kPa.
10. All pipe shall be either type "L" or "K" copper pipe (certified to ASTM B88) or stainless steel pipe rated to a minimum working pressure of 1,035 kPa. All pipe flanges shall be threaded or welded to the pipe. Galvanized, Polyethylene, PVC and other plastic pipe and fittings shall not be permitted.
11. All check valves, backflow preventers, pressure reducing valves, cross connection control devices and all other such devices shall be located downstream of the outlet tee. No other fittings or connections shall be allowed upstream of such devices.
12. No bends, tees or other fittings shall be allowed between the inlet & outlet valves other than the water meter.
13. The by-pass valve shall be attached to the inlet tee, the flushing valve shall be attached to the outlet tee and the drainage valve shall be positioned between the by-pass valve and the flushing valve as close as possible to the outlet tee. All valves shall be configured such that their handles shall not interfere with each other and all valves shall be readily accessible for operation, repair or replacement.
14. Any insulation placed on or around any water meter shall be easily removable and replaceable and shall not contain asbestos or any other toxic or hazardous materials. Such insulation shall not cover or obstruct the water meter register. The City shall not be responsible for any damage to such insulation during any removal or replacement of such insulation.
15. The private water service pipe shall be flushed prior to and after the installation of the water meter.
16. For remote readout device wire and conduit installation, refer to City of Toronto Specifications.



TECHNICAL SERVICES
Engineering Services - Works Facilities & Structures

SCALE:	N.T.S.	PIPING LAYOUT FOR METER CHAMBER UP TO 50 mm PRIVATE WATER SERVICE PIPE	DRAWING NUMBER: T-1107.01-1
DATE:	FEBRUARY 2006		SHEET: 2 of 2
DRAFTING:	V.D. / L.B-H.		