

TYPE "A"

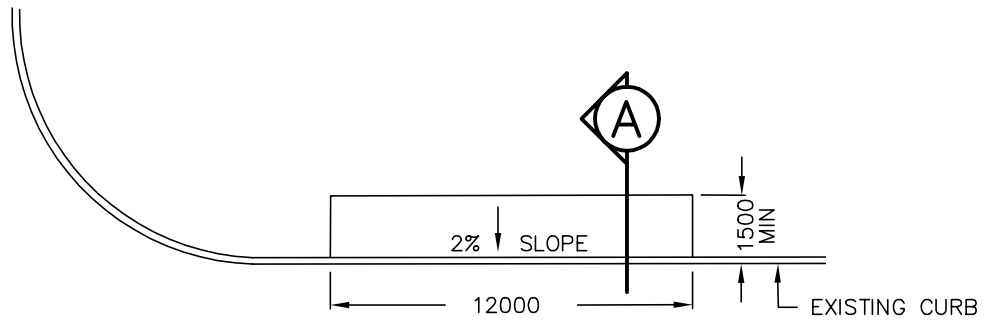

TYPE "B"

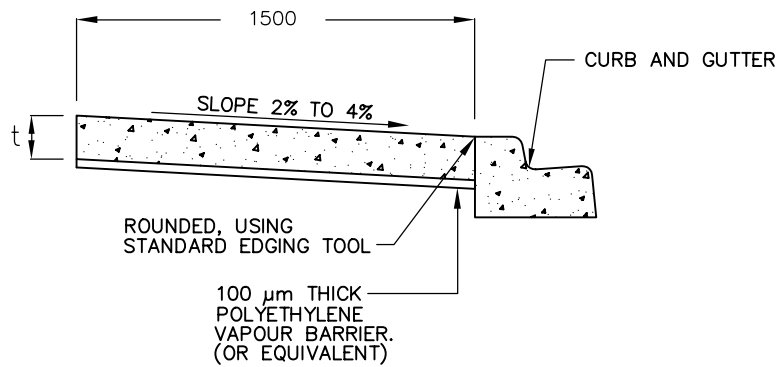

SECTION

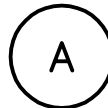

t = THICKNESS OF SIDEWALK

NOTES:

1. FOR CONCRETE SIDEWALK ABUTTING CURB OR CURB AND GUTTER REFER TO T-600.05-1 & T-600.11-1
2. SIDEWALK THICKNESS 130mm EXCEPT ACROSS COMMERCIAL, INDUSTRIAL AND HIGH DENSITY RESIDENTIAL DRIVEWAY WHERE THICKNESS SHALL BE 180mm.

METRIC
ALL DIMENSIONS SHOWN HERE ARE IN
MILLIMETRES UNLESS OTHERWISE NOTED



WORKS & EMERGENCY SERVICES

TECHNICAL SERVICES DIVISION
Engineering Services - Works Facilities & Structures

BUS STOP LANDING

SCALE:

N.T.S.

DATE:

APRIL, 2003

DRAFTING:

V. DIDIANO

DRAWING NUMBER:

T-310.010-8

SHEET:

1