

DETAIL 'A'
(TTD 810.005)

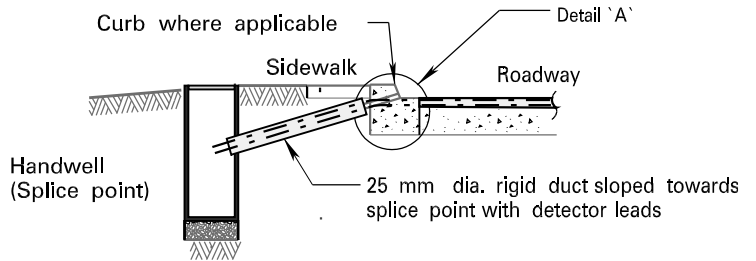

SECTION A-A
(TTD 810.005)

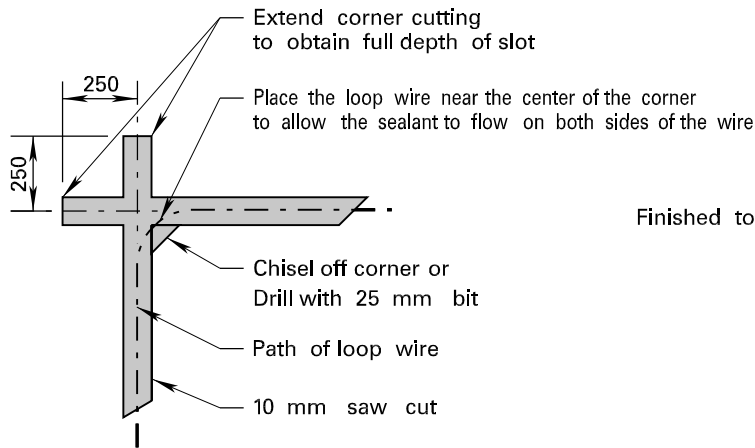

DETAIL 'B'
(TTD 810.005)

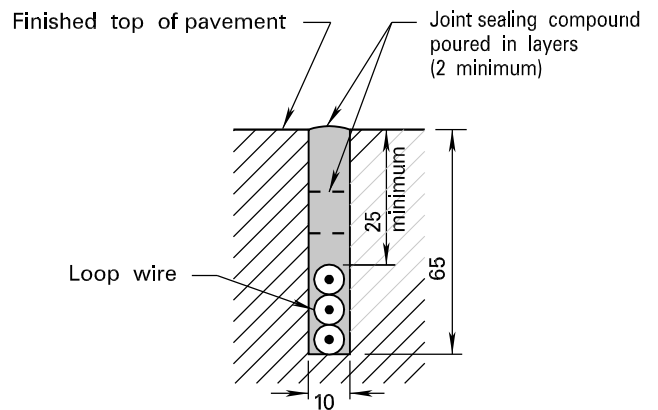

SECTION B-B
(TTD 810.005)

NOTES

A This drawing shall be read in conjunction with TTD 810.005.
All dimensions are in millimetres or metres unless otherwise shown.