

This cover page contains information about the contents of the PDF document that follows.

Name of document:

Boulevard Café Application Information Package

Overview:

This documents contains information to assist someone who is applying for a Boulevard café licence in the City of Toronto. It includes sample site plan sketches and other information.

Who to contact for more information:

Road Allowance Unit, Licensing Services, Municipal Licensing & Standards

East York Civic Centre, 850 Coxwell Avenue, 3rd Floor, Toronto, ON M4C 5R1

Road Allowance Fax: 416-392-4515

Information Line: 416-392-6700

Email: mlsbusinesslicence@toronto.ca

Website: www.toronto.ca/roadallowance

Hours: Monday to Friday, 8:30 a.m. to 4:00 p.m., except Statutory Holidays

311

You may also contact 311, available 24/7, 365 days per year.

E-mail: 311@toronto.ca

Phone within Toronto: 311

Phone outside Toronto: 416-392-CITY (2489)

TTY customers: 416-338-0TTY (0889)

Website: www.toronto.ca/311

Boulevard Café Permit – Former Toronto**Applicant Information**

Operating Name for Restaurant

Restaurant Address (include postal code)

Restaurant Telephone No.

Alternate Telephone No.

Name of Owner (First, Last) Please circle title: Mr. Mrs. Ms. Miss

Business Mailing Address (include postal code)

Name of Corporation, Business or Partnership of the Restaurant

Municipal Licensing & Standards Business Licence No. (Attach a copy.)

Expiry Date (yyyy-mm-dd)

Café InformationProposed Dimensions: m X mAre you applying to use a barbecue within the boulevard café? Yes NoAre you applying to have an awning(s) over the boulevard café? Yes (Provide 10 sets of plans.) NoAre you applying to use a heater(s) within the boulevard café? Yes NoFence to enclose the boulevard café: Chain Link Wrought Iron Open-Board Lattice Other:

Note: Maximum height not to exceed 1.2 meters and construction must be removable.

The following items must be submitted with your application:

- A non-refundable administrative fee of **\$256.80** including HST (subject to change without notice).
- A sketch and current photograph which clearly show all relevant dimensions, the location of the street and City sidewalk, side property line(s), fence enclosing proposed café area, utility poles, fire hydrant, trees, etc., and paving material. If required to pave boulevard, more detailed drawings may be required if your proposal involves major landscaping.
- Copy of Municipal Licensing & Standards Business Licence.
- Third party liability insurance policy, satisfactory to the Commissioner (form attached).
- If applying for propane operated equipment, e.g., barbecues or heaters, a certificate from the Ministry of Consumer and Commercial Relations is required for operators and equipment.

Upon approval of your application, it will be necessary to:

- Enter into an agreement with the City of Toronto.
- Install approved fence around the perimeter of the café and remove fence at the end of each café season.
- Pay an annual fee for the use of the boulevard in accordance with Municipal Code Chapter 313, Streets and Sidewalks. Fees are available online at www.toronto.ca/mlsfees.

Until all approvals have been granted, permits issued and agreements executed, operations of the café, any required construction, or related activities are not permitted within the City boulevard.

Authorized Signature

Signature of Applicant:

Date(yyyy-mm-dd)

Certificate of Insurance

To be completed only by the insurer or its authorized representative.

Name of Insured (First, Last)	Operating as:	
<input type="text"/>	<input type="text"/>	
Address of Insured (include postal code)		
<input type="text"/>		
Telephone No. of Insured	Alternate Telephone No.	
<input type="text"/>	<input type="text"/>	
Name of Insurance Company		
<input type="text"/>		
Operations of the named insured for which this certificate is issued:		
<input type="text"/>		
Commercial General Liability (minimum limit to be \$2,000,000)	Coverage (per occurrence)	
<input type="text"/>	<input type="text"/>	
Policy No. / Insuring Company	Effective Date(yyyy-mm-dd)	Expiry Date(yyyy-mm-dd)
<input type="text"/>	<input type="text"/>	<input type="text"/>

Provisions of Amendments or Endorsements of Listed Policies

Commercial General Liability is extended to include Personal Injury Liability, Contractual Liability, Owner's and Contractor's Protective Coverage, Products-Completed Operations, Contingent Employers Liability and Non-owned Automobile Liability. The City of Toronto has been named as an Additional Insured but only with respect to liability arising out of the operations of the Insured for which a permit, licence or agreement has been issued by the City of Toronto. The Commercial General Liability policy or policies identified above shall protect each insured in the same manner and to the same extent as though a separate policy has been issued to each, but nothing shall operate to increase the limits of liability as identified above beyond the amount or amounts for which the company would be liable if there had been only one Insured. If insurance is placed in primary and excess layers, file separate certificates for each. If a facsimile has been transmitted, the original certificate must follow. The Commercial General Liability policies identified above shall apply as the primary insurance and not excess to any other insurance available to any of the Additional Insured as set out in Paragraph 2. If the policy is canceled or changed in any manner, for any reason, during the period of coverage as stated herein so as to affect this certificate, thirty (30) days prior written notice (10) days if cancellation is due to non-payment of premium) by registered mail will be given by the insurer to:

Attention: Road Allowance Unit, Licensing Services, Municipal Licensing & Standards
East York Civic Centre, 850 Coxwell Avenue, 3rd Floor, Toronto, ON M4C 5R1, Fax: 416-392-4515

Broker Information

Name of Insurance Broker (First, Last)	
<input type="text"/>	
Telephone No. of Broker	Email Address of Broker
<input type="text"/>	<input type="text"/>
Address of Insurance Broker (include postal code)	
<input type="text"/>	

Authorized Signature

I certify that the insurance is in effect as stated in this certificate and that I have authorization to issue this certificate for and on behalf of the insurer(s). This certificate is valid until the expiration date(s) shown unless notice is given in writing.

Signature and Stamp of Authorized Representative	Date(yyyy-mm-dd)
<input type="text"/>	<input type="text"/>

The acceptance of this certificate by the City of Toronto does not certify that the limits of liability and terms and conditions of the policy referred to above meet the specified requirements of the Commissioner of Finance nor will the acceptance of this certificate by the City waive the City's rights of action against the application and/or insurer for failure to comply with provisions governing the use of permits and licences granted herein.

Boulevard Café Permit – Former Toronto**Boulevard Café Permit Check List**

<input type="checkbox"/> Yes	Provide the name and signature of the Business Owner (contact).
<input type="checkbox"/> Yes	Provide a copy of the pages(s) of the Corporate Document showing names(s) of signing officer(s), if a corporation.
<input type="checkbox"/> Yes	Provide a copy of Business Licence from Municipal Licensing & Standards Business Licensing Office, if applicable.
<input type="checkbox"/> Yes	Provide the enclosed Certificate of Insurance (original form only) completed, signed and stamped by agent (authorized representative).
<input type="checkbox"/> Yes	Provide 10 copies of a sketch clearly showing all relevant dimensions, the location of the street and City sidewalk, side property line(s), fence enclosing proposed café area, utility poles, fire hydrants, trees, all street furnishings, etc. Paving material, if required, to pave boulevard (more detailed drawings may be required if proposal involves major landscaping).
<input type="checkbox"/> Yes <input type="checkbox"/> No	Three photos of the location, one face on and the others lengthwise across the property. If you are applying for a frontage and a flankage two sets of photos are required.
<input type="checkbox"/> Yes <input type="checkbox"/> No	If applying for an awning over the café area you will be required to provide detailed sketch of the proposed installation for circulation. A certificate indicating the Fire Proof Rating of the fabric is required.
<input type="checkbox"/> Yes	Provide \$256.80 (includes HST) non-refundable application fee made payable to Treasurer, City of Toronto. * Application will NOT be issued and/or renewed if there are any outstanding Provincial Offences Fines. Proof of Payment Required.

Sample application documents are available at www.toronto.ca/roadallowance.

Road Allowance Unit, Licensing Services, Municipal Licensing & Standards

East York Civic Centre, 850 Coxwell Avenue, 3rd Floor, Toronto, ON M4C 5R1

Road Allowance Fax: 416-392-4515

Information Line: 416-392-6700

Email: mlsbusinesslicence@toronto.ca

Website: www.toronto.ca/roadallowance

Hours: Monday to Friday, 8:30 a.m. to 4:00 p.m., except Statutory Holidays

Important Notice

As per Municipal Code Chapter 313-36E 18(d):

If the proposed café area on the flankage is found to be suitable for tree planning, a non-refundable fee in the amount of \$3000 is required. [Who is "EDC"?)

Sample

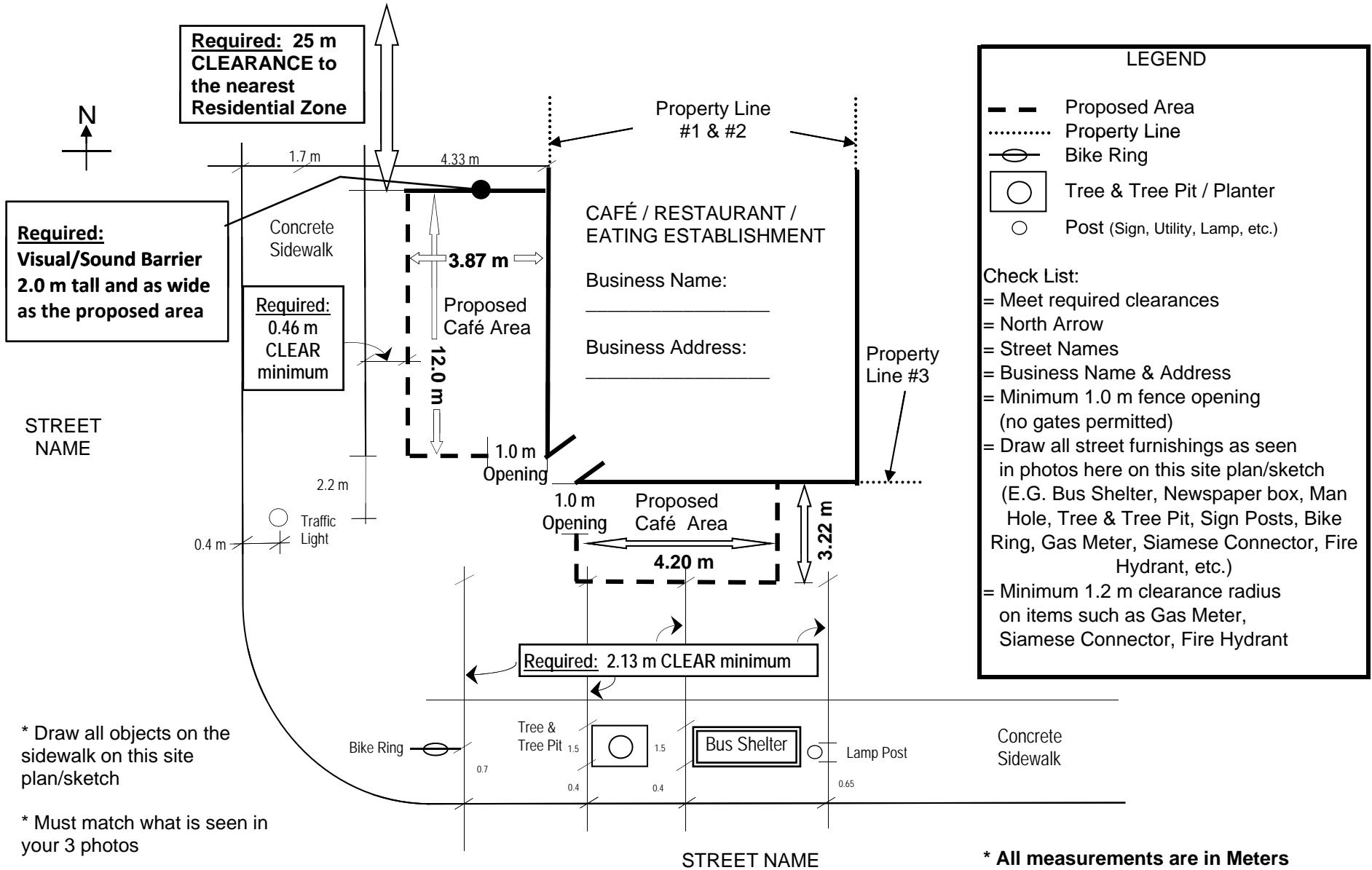

* Draw all objects on the sidewalk on this site plan/sketch

* Must match what is seen in your 3 photos

Sample Café Fence Sketch

Maximum Height
0.914 m - 1.2 m
(36" - 47")

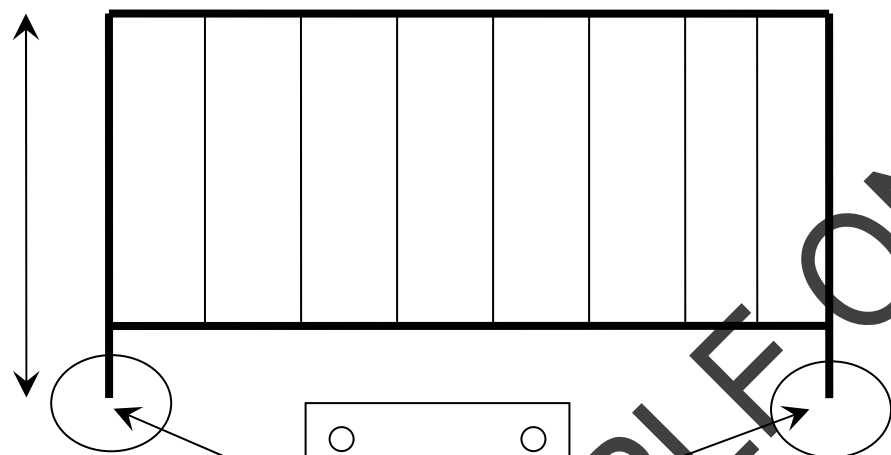

Bolted metal plates will secure the wrought iron fence to sidewalk. Plates will be affixed by nuts and bolts at a depth of 3 inches.

Sample Visual Barrier Fence Sketch (For businesses on a corner lot only; Flankside Only)

As wide as the proposed
Café Area

Between wooden slats is
about 2-3 inches apart OR
overlapping boards design

Maximum Height
2.0 m (78.74")

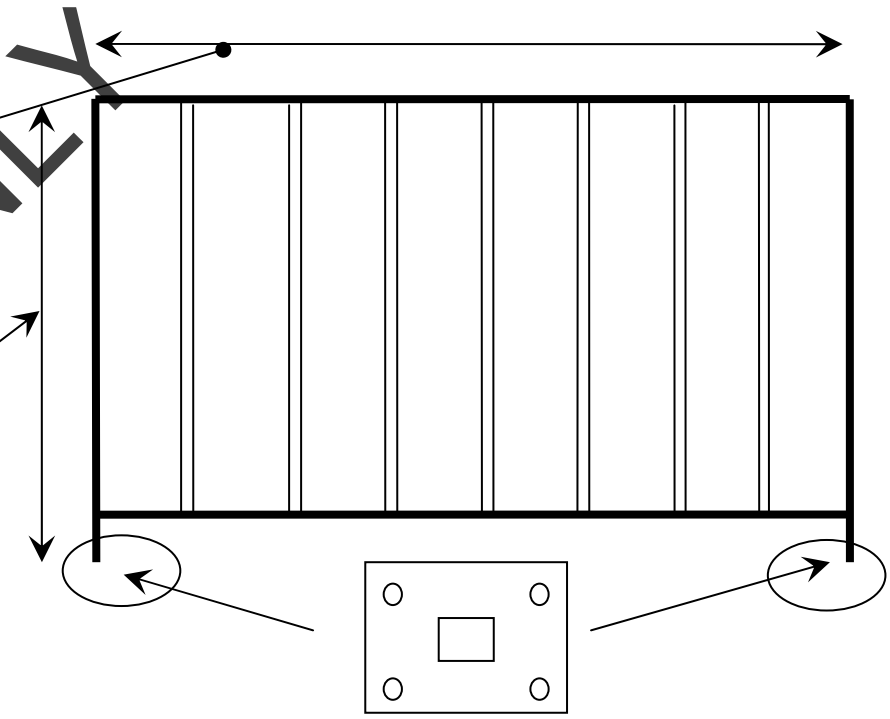

Business Name: (e.g. 12345 Ontario Ltd.)
Operating As: (e.g. Happy Restaurant)

Business Address: (e.g. 850 Coxwell Avenue)

SIDE ELEVATION OF A TYPICAL AWNING

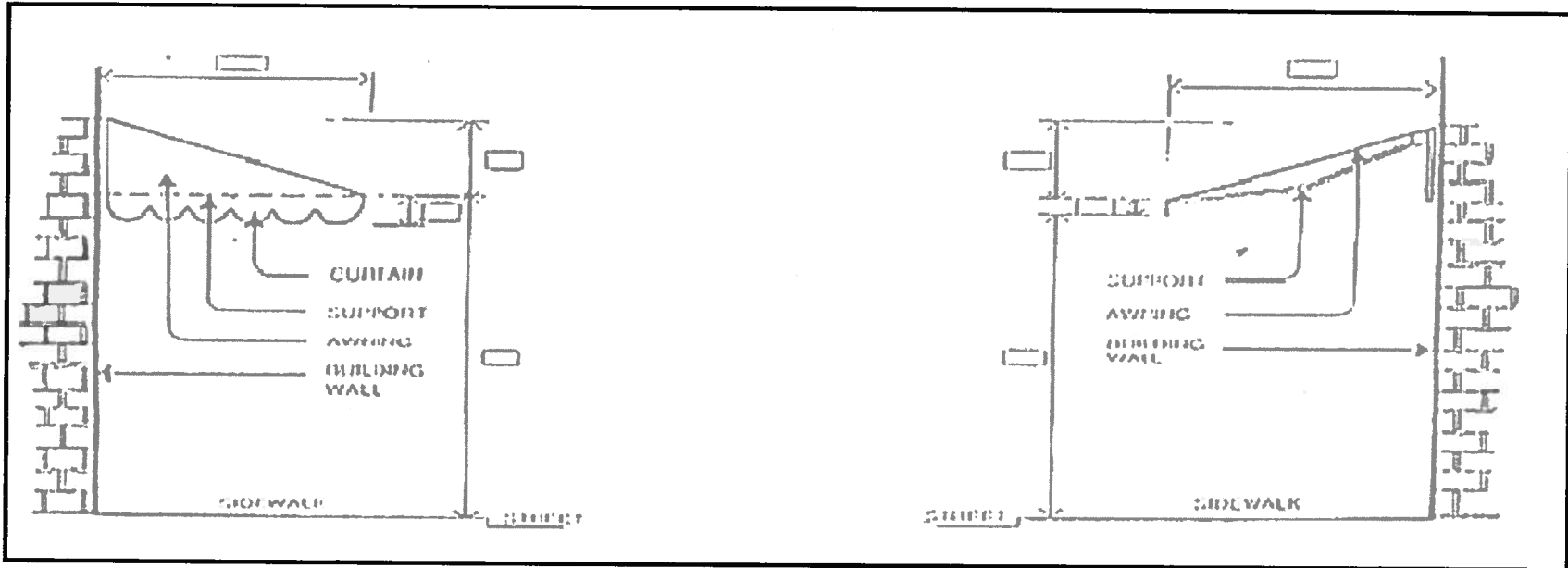

YES NO

- | | | |
|--------------------------|--------------------------|--|
| <input type="checkbox"/> | <input type="checkbox"/> | Will the awning be supported on a framework which will be secured to the building? |
| <input type="checkbox"/> | <input type="checkbox"/> | Will any part of the awning or its framework (except the "curtain") be less than 2.36 m (7'9") above the level of the street or sidewalk? |
| <input type="checkbox"/> | <input type="checkbox"/> | Will the curtain be less than 2.13m (7'0") above the level of the street or sidewalk? |
| <input type="checkbox"/> | <input type="checkbox"/> | Will information other than the business address & telephone number appears on the awning? (if yes, separate approval is required from Buildings Division) |

Please provide measurements in the appropriate boxes for whichever of the above styles most closely matches your proposed awning, a **Certificate of Fire Proof Rating Required** and a **fabric sample 5 cm x 5 cm** (2 inches x 2 inches).

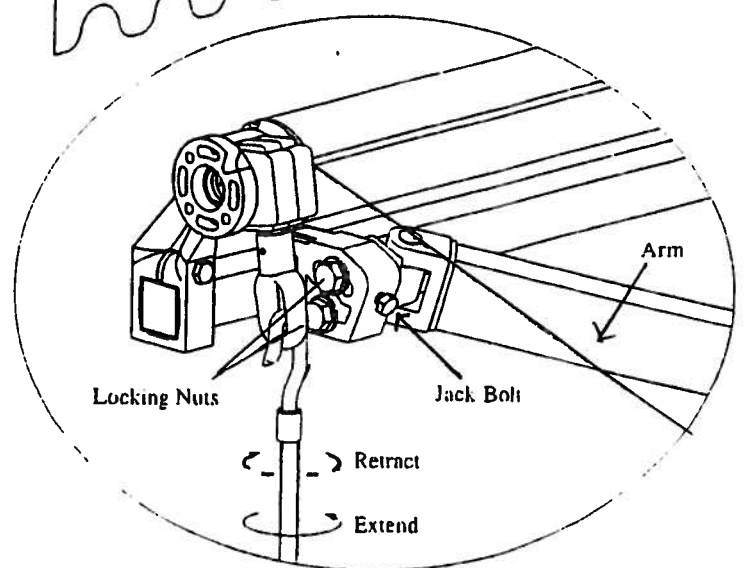
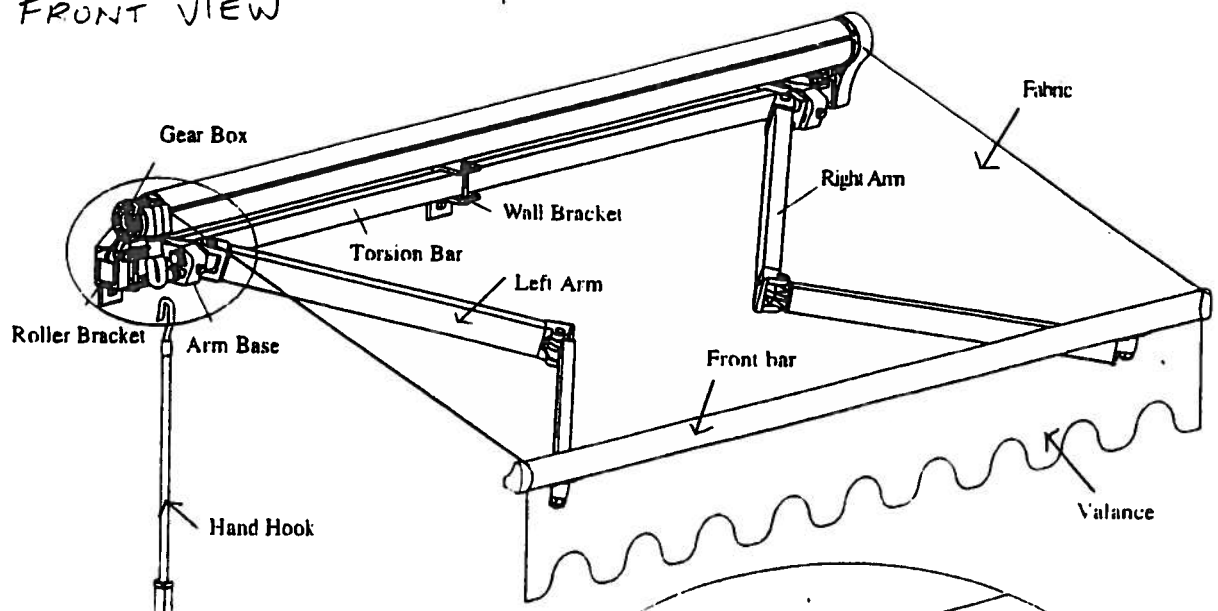
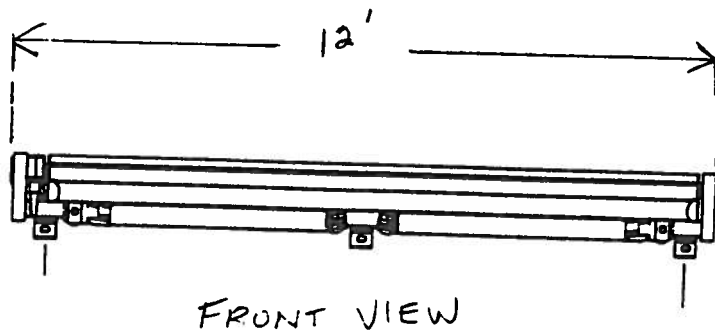
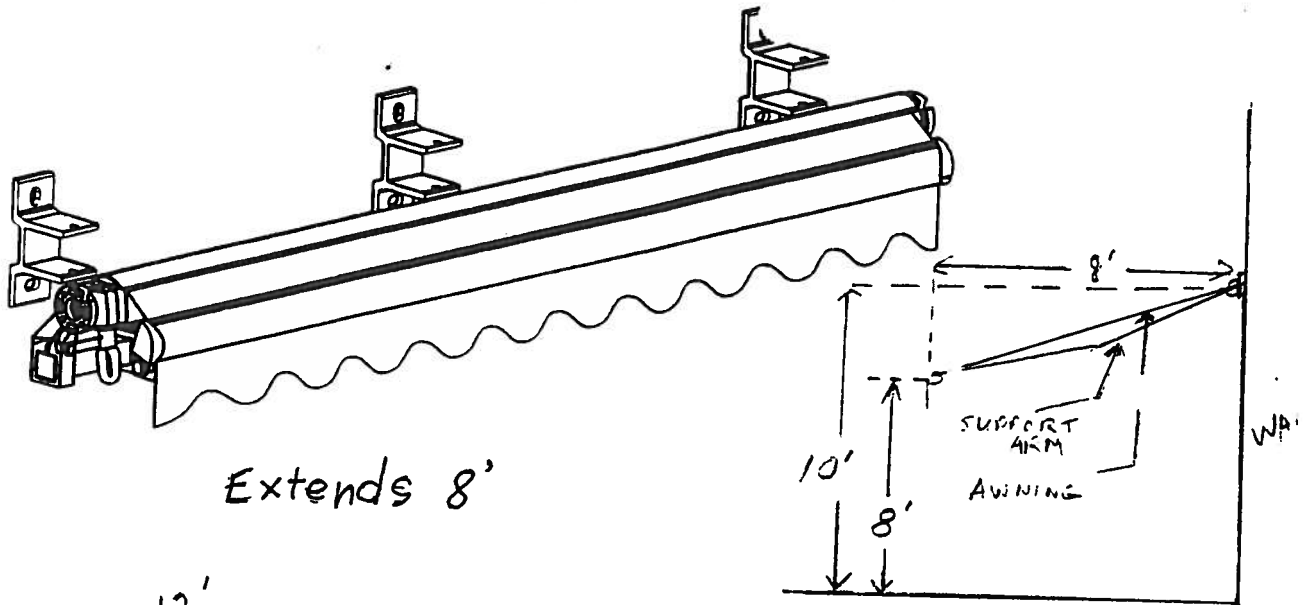

SAMPLE
ONLY



GENERIC CLASSIFICATION	Solution Dyed Modacrylic.
DESCRIPTION	Woven fabric made of 100% SEF/PLUS® Self-extinguishing fibers. These are modacrylic solution dyed fibers with a fluorocarbon finish
WEIGHT	Approximately 9.25 oz. per square yard 31.4 grams per square meter
WIDTH	60 inches or 152.4 cm.
COLOR	Very resistant to ultraviolet rays & color degradation (see warranty). Most colors tested up to 1500 hours in fadeometer with minimal or no change. Fade resistant to most chemicals
DURABILITY / AVERAGE LIFE SPAN	5-10 years. (Depends on climate & proper use of fabric.)
SURFACE	Plain weave. Excellent breathability
UNDERSIDE	Same as top surface, both sides alike.
TRANSPARENCY LEVEL	Light shades translucent for good illuminated use.
ABRASION RESISTANCE	Good
FLEXIBILITY	Excellent in both hot & very cold conditions. Will not crack or peel.
FABRIC IDENTIFICATION	Contrasting marker yarn in selvage gives positive identification
FLAME RESISTANCE (FRI)	Fabric does not melt drip & is inherently flame retardant passing the following flame retardant requirements: <ul style="list-style-type: none"> • California State Fire Marshall Title 19, Section 1237 Registration #FA-36801. • NFPA 701-99 Test Method 2 • ASTM E-84-03 - Values for flame spread and smoke density are Class A or Type I building material • F.A.A. 25.853(a) interior aircraft textiles and furnishings. • FMVSS302 Auto, bus, train. • CPAI-84 Tent walls and roof. • New York Board of Standards: 29.4-40-5R • UFAC: Upholstered furniture Class 1 • NFPA 1975 - Fireman's Station Uniform (FTMS No. 191, Method 59C3) • Outside North America - Consult Glen Raven for Specifications
MILDEW RESISTANT	Excellent. Fabric will not support growth of mildew. Mildew growing on foreign matter attached to fabric is easily removed.
CHEMICAL RESISTANCE	Fabric highly resistant to acids, alkalis, & solvents.
WATER REPELLENCY	Excellent
OIL RESISTANCE	Good.
SEWABILITY	Excellent
HEAT SEALING	Can be heat sealed using sealing tape & heat source such as radio frequency bar type welder.

GENERIC CLASSIFICATION	Solution Dyed Modacrylic with an acrylic/urethane coating.
DESCRIPTION	Woven fabric made of 100% SEF/PLUS® Self-extinguishing fibers. These are modacrylic solution dyed fibers with a fluorocarbon finish
WEIGHT	Approximately 10.25 oz. per square yard, 348 grams per square meter
WIDTH	60 inches or 152.4 cm
COLOR	Very resistant to ultraviolet rays & color degradation (see warranty). Most colors tested up to 1500 hours in fadeometer with minimal or no change. Fade resistant to most chemicals
DURABILITY / AVERAGE LIFE SPAN	5-10 years. (Depends on climate & proper use of fabric.)
SURFACE	Plain weave.
UNDERSIDE	Coated with acrylic/urethane.
TRANSPARENCY LEVEL	Light shades translucent for good illuminated use
ABRASION RESISTANCE	Good.
FLEXIBILITY	Excellent in both hot & very cold conditions. Will not crack or peel.
FABRIC IDENTIFICATION	Contrasting marker yarn in selvage gives positive identification.
FLAME RESISTANCE (FRI)	Fabric does not melt drip & is inherently flame retardant passing the following flame retardant requirements: <ul style="list-style-type: none"> • California State Fire Marshall Title 19, Section 1237 Registration #FA-36804. • NFPA 701-99 Test Method 2 • ASTM E-84-03 - Values for flame spread and smoke density are Class A or Type I building material • F.A.A. 25.853(a) interior aircraft textiles and furnishings. • FMVSS302 Auto, bus, train • CPAI-84: Tent walls and roof • New York Board of Standards: 29.4-40-5R • UFAC: Upholstered furniture Class 1. • Outside North America - Consult Glen Raven for Specifications
MILDEW RESISTANT	Excellent. Fabric will not support growth of mildew. Mildew growing on foreign matter attached to fabric is easily removed.
CHEMICAL RESISTANCE	Fabric highly resistant to acids, alkalis, & solvents.
WATER REPELLENCY	Superior
OIL RESISTANCE	Good.
SEWABILITY	Excellent
HEAT SEALING	Can be heat sealed using sealing tape & heat source such as radio frequency bar type welder.

SUNBRELLA FIRESIST® & SUNBRELLA FIRESIST® "PLUS" five year limited warranty



This limited warranty is valid only if a copy of the invoice for the item purchased is submitted showing date of original purchase. This limited warranty covers the fabric becoming unserviceable because of loss of color or strength from normal usage and exposure conditions, including sunlight, mildew and atmospheric chemicals. Consumer is responsible for normal care and cleaning of the fabric. This warranty covers fabric only. Glen Raven's liability is expressly limited to this warranty. This limited warranty coverage runs for five years from the date of original installation. Glen Raven will supply new fabric free to replace the fabric that becomes unserviceable. Call the dealer or retailer from whom you purchased the product to inspect the damaged area. They will contact the manufacturer of the item purchased. The manufacturer will then contact Glen Raven and secure replacement fabric for you.



Glen Raven Custom Fabrics, LLC 1831 North Park Avenue, Glen Raven, NC 27217 Tel: 336.221.2211 Fax: 336.586.1169

Glen Raven® and Sunbrella Firesist® are registered trademarks of Glen Raven, Inc.

SAMPLE ONLY

CAFÉ PATIO DECK - SIDE ELEVATION OF A TYPICAL DECK

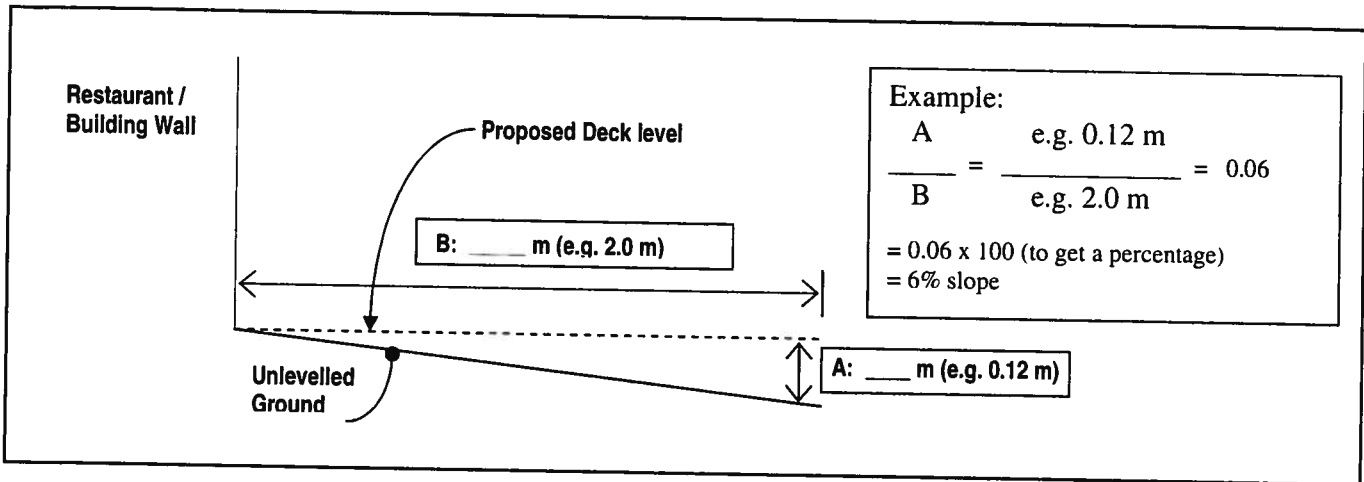

Please provide the following information as a part of the approval process for a café patio deck:

Does the proposed deck meet the following requirements?	
YES	NO
<input type="checkbox"/>	<input type="checkbox"/>
The deck shall be no higher than what is required to accommodate a level area and the deck framing members (which shall be the minimum depth required).	
<input type="checkbox"/>	<input type="checkbox"/>
Wood used for the decking, skirt, uprights, or railing shall be treated, painted, or stained.	
<input type="checkbox"/>	<input type="checkbox"/>
Wood is used for the uprights;	
(i) post widths shall not exceed 0.10 m x 0.10 m (4 x 4 inches);	
(ii) top and bottom railings shall not exceed 0.06 m x 0.09 m (2.5 x 3.5 inches);	
(iii) pickets or balusters shall not exceed 0.04 m x 0.04 m (1.5 x 1.5 inches); and	
(iv) the spacing between the pickets or balusters shall not exceed 0.10 m (4 inches)	
<input type="checkbox"/>	<input type="checkbox"/>
A minimum width of 1.03 m (3.3 ft.) break in the railing shall be provided at the high side of the slope to provide wheelchair access.	
<input type="checkbox"/>	<input type="checkbox"/>
Boulevard café decks shall not be constructed over existing underground services (i.e. hydro vaults, chambers, maintenance holes, etc.), except with prior written approval given by the relevant public utility.	
<input type="checkbox"/>	<input type="checkbox"/>
Regarding the outdoor carpeting, artificial turf or other similar surface material upon the paved surface of any portion of the boulevard:	
(a) The surface material shall not be affixed in any way to the paved surface and shall be maintained in a condition satisfactory to the Commissioner.	
(b) The surface material shall be designed and installed to prevent hazardous conditions at any entrance to a boulevard café area.	
(c) The surface material shall be removed from within the street allowance when the boulevard café ceases to be in regular daily use.	
Provide 5 copies of a diagram with the following information:	
<input type="checkbox"/>	<input type="checkbox"/>
Side elevation diagram of measurements and mathematical calculation depicting a 5% slope; indicate your business name and address on it.	
<input type="checkbox"/>	<input type="checkbox"/>
Stating the width and length, details of how the structure is assembled and details of how it can be easily be removed / taken apart to clean underneath and/or access to underground services.	