

**DETAIL A**

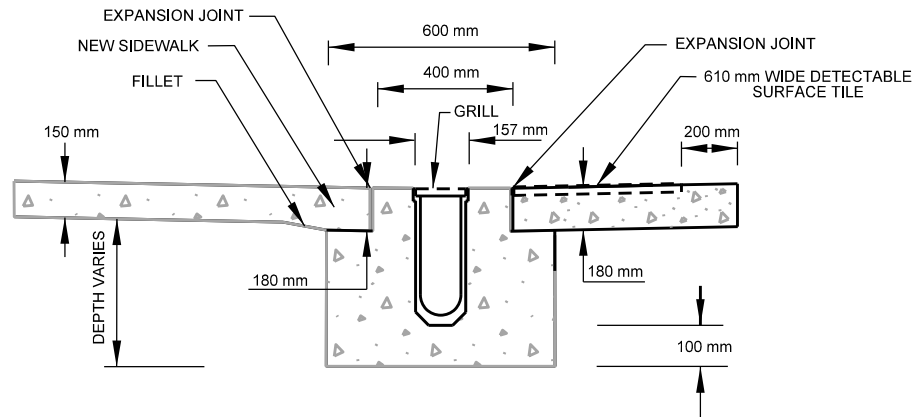

**NOTES :**

1. LOAD TRANSFER TIE BARS TO BE PROVIDED BY DRILLING 40 mm HOLES ON 300 mm CENTRES, 225 mm DEEP INTO EXISTING CONCRETE ROAD BASE, 100 mm DEEP INTO EXISTING CURB AND SIDEWALK, AND GROUT THE BARS USING A QUICK SETTING MORTAR. EPOXY COATED DEFORMED TIE BARS TO BE 25 mm x 450 mm FOR ROAD BASE AND 25 mm x 200mm FOR CURB AND SIDEWALK.

All dimensions are in millimetres unless otherwise shown.



ENGINEERING & CONSTRUCTION SERVICES STANDARD DRAWING

**RAISED CYCLE TRACK AND BOULEVARD WITH TRENCH DRAIN**

REV 0

SEP 2019

**T-990.200**

NTS

SHEET 1