

PLAN VIEW  
(NTS) A

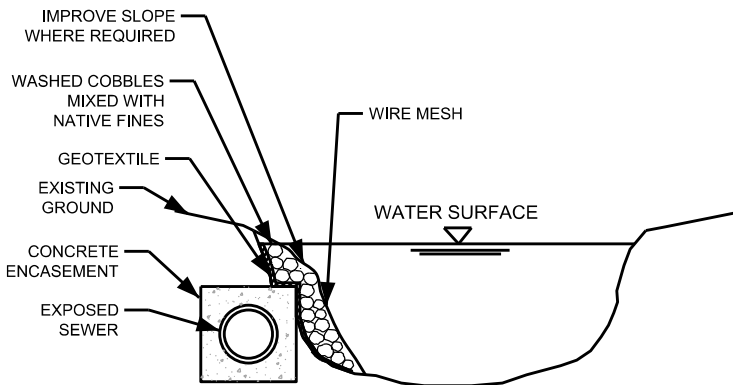

SECTION VIEW  
(NTS) B

NOTES:

1. IF REQUIRED, CONSTRUCTION ACCESS PATH AS PER CONTRACT DRAWINGS AND PERMIT APPROVALS.
2. THE FOLLOWING SURVEYS/INVESTIGATIONS ARE REQUIRED:
  - a) SUBSURFACE UTILITY ENGINEERING
  - b) GEO-MORPHOLOGY
  - c) GEO-TECHNICAL
3. DIVERT WATER DURING CONSTRUCTION. DIVERSION SHALL BE APPROVED BY THE TRCA.
4. CAREFULLY EXCAVATE AROUND EXISTING SEWER. HEAVY MACHINERY SHALL NOT BE USED. SUPPORT SEWER AT REGULAR INTERVALS AND BRACE ALL JOINTS DURING CONSTRUCTION.
5. WORK TO BE CONDUCTED DURING LOW FLOW SEASON.
6. SUPPORT SEWER DURING CONSTRUCTION.
7. THE CONTRACTOR TO PROVIDE THE CONCRETE MIX DESIGN TO ACCOMMODATE PVC PIPE AND OTHER PIPE MATERIALS.
8. REPAIR EXPOSED SECTION IN 2m INTERVALS.
9. INSTALL EROSION AND SEDIMENT CONTROLS PER THE GEO-MORPHOLOGY RECOMMENDATIONS AND PERMIT APPROVAL.
10. PIPE FOUNDATION AND BEDDING AS PER GEO-TECHNICAL REPORT RECOMMENDATIONS.
11. TRENCH WIDTH: PIPE O.D. PLUS 2x450mm (MIN) TO 2x750mm (MAX), UNLESS PROJECT SPECIFIC BEDDING STATES OTHERWISE.
12. GEOTEXTILE FABRIC, WIRE MESH AND SLOPE COBBLES MIXED WITH NATIVE FINES AS PER THE GEO-MORPHOLOGY REPORT RECOMMENDATIONS.
13. ALL DIMENSIONS ARE NOMINAL.

All dimensions are in millimetres unless otherwise shown.

NOTE:  
THE ENGINEERING CONSULTANT SHALL CONSULT WITH THE TRCA PRIOR TO INCLUDING THIS DETAIL IN THEIR PERMIT APPLICATION AND INCLUDING IT IN THE TENDER CALL. THIS DETAIL MAY REQUIRE SPECIFIC CHANGES AND ALL DIMENSION ADJUSTMENTS BASED ON COMMENTS RECEIVED FROM THE TRCA.

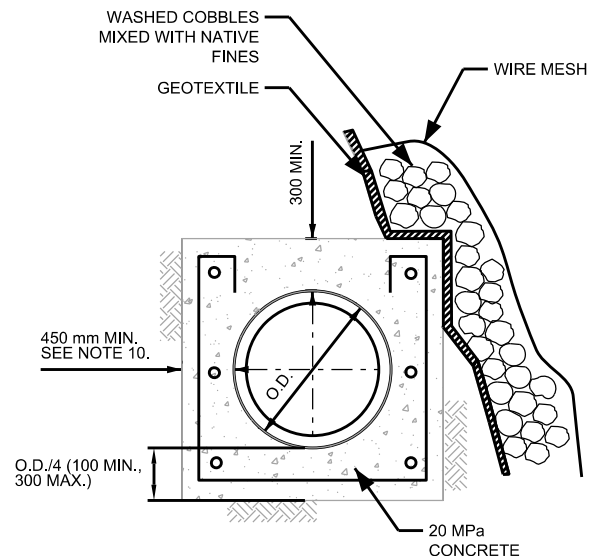

DETAIL VIEW  
(NTS) C



ENGINEERING & CONSTRUCTION SERVICES STANDARD DRAWING

REV 0

SEP 2019

**TYPICAL REPAIR OF EXPOSED  
SEWER PARALLEL TO A CREEK**

**T-1120.02-2**

NTS

SHEET 1