

SECTION VIEW
(NTS)

A

THE MAXIMUM DISTANCE FROM THE COVER TO THE TOP OF THE LADDER IS 600mm

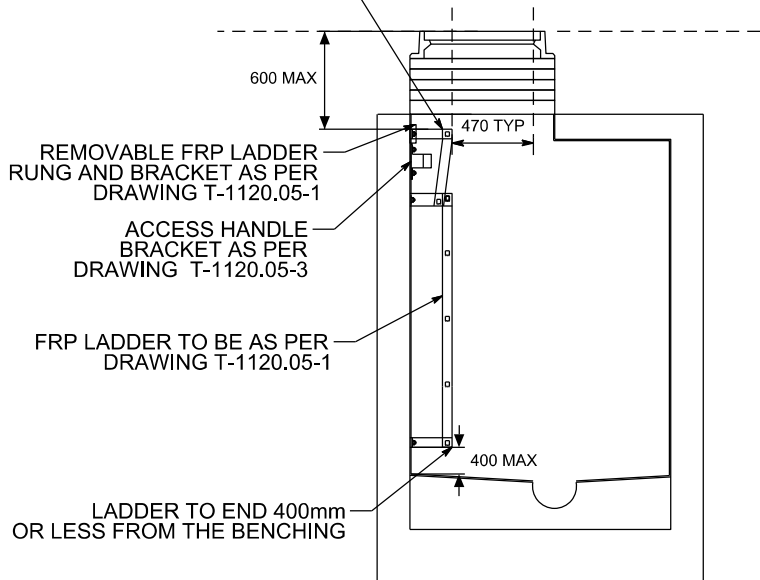

SECTION VIEW
(NTS)

B

NOTES:

- FIRST STEP TO BE 75 TO 450 BELOW FRAME. LAST STEP TO END 400mm OR LESS FROM BENCHING.

All dimensions are in millimetres unless otherwise shown.



ENGINEERING & CONSTRUCTION SERVICES STANDARD DRAWING

REV 0

SEP 2019

**FRP LADDER FOR CIRCULAR MAINTENANCE HOLES
LESS THAN 4.5m DEPTH**

T-1120.05-4

NTS

SHEET 1