

SECTION

A

SECTION

B

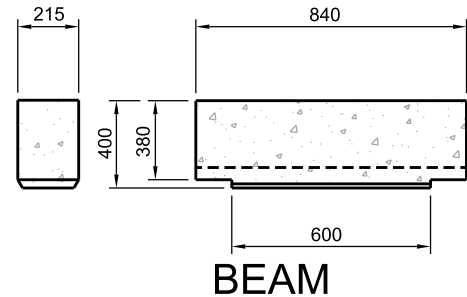
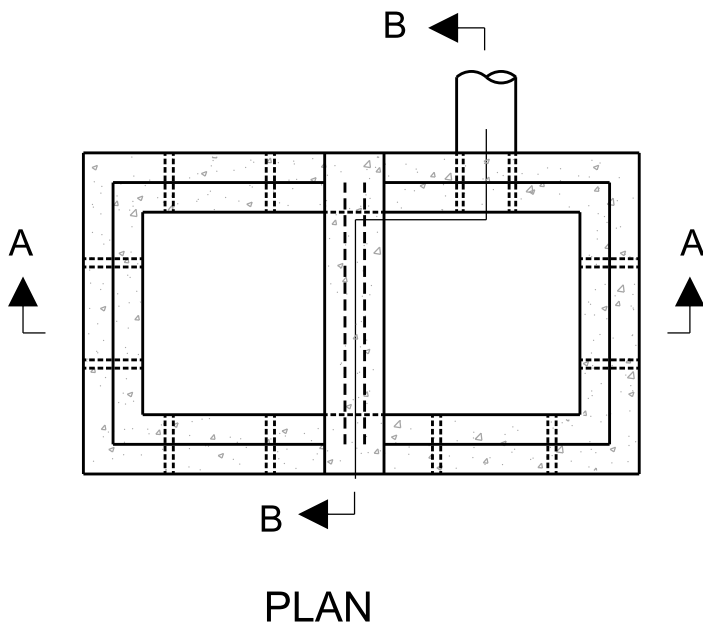

NOTES:

1. CONCRETE SHALL BE 32 MPa AT 28 DAYS.
2. PARGING MIX ON ALL BRICKWORK SHALL BE 1:3 MORTAR MIX AND APPLIED 15 mm THICK.
3. ALL JOINTS AND LIFTING HOLES SHALL BE COMPLETELY FILLED WITH A 1:3 MORTAR MIX AND POINTED BEFORE BACKFILLING.
4. BACKFILL SHALL BE UNSHRINKABLE FILL.
5. WHERE WEEPHOLES ARE USED BACKFILL WITH 50 mm CRUSHED STONE IN MIN. 300 mm WEDGE TO DEPTH OF WEEPHOLES.
6. ALTERNATE WALL THICKNESS SHALL BE 150 mm WHERE SPECIFIED.

All dimensions are in millimetres unless otherwise shown.



ENGINEERING AND CONSTRUCTION SERVICES STANDARD DRAWING

PRECAST DOUBLE CATCH BASIN
WITH SUMP

REV 1

APR 2013

T-705.020

NTS

SHEET 1