

PLAN

* IF PROXIMITY OF FULL DEPTH REPAIR TO EXISTING JOINT OR CRACK IS 2.0 m OR LESS, EXTEND CONCRETE REPLACEMENT TO 300 mm BEYOND JOINT OR CRACK.

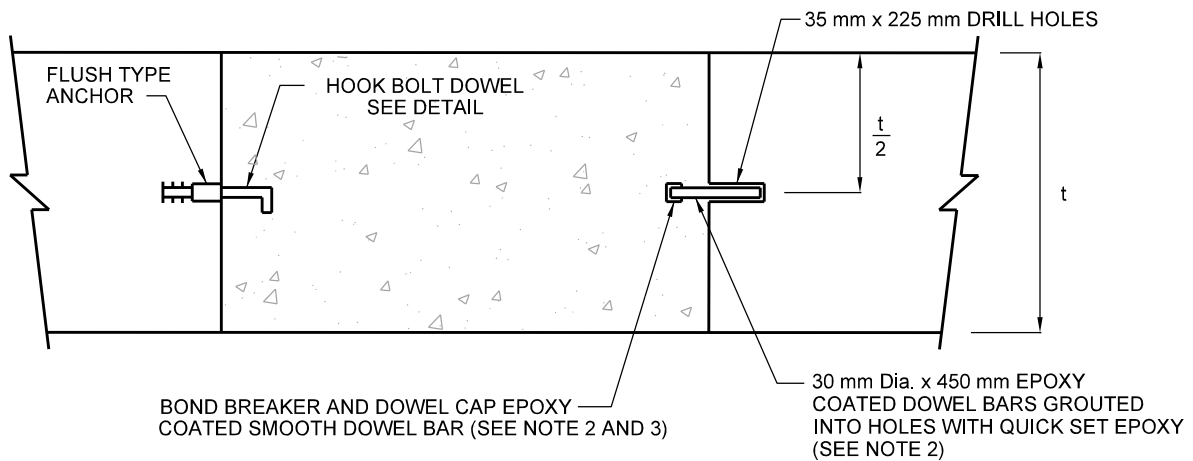

SECTION A - A

NOTES:

1. JOINT SPACING TO MATCH EXISTING.
2. THE GROUT SHALL ENVELOP THE BAR WITHIN THE DRILL HOLE. THE GROUT SHALL BE FULLY SET PRIOR TO POURING THE NEW CONCRETE.
3. THE FREE END OF THE DOWEL BARS SHALL RECEIVE A THIN AND UNIFORM COATING OF GREASE (BOND BREAKER) AND A DOWEL CAP IMMEDIATELY PRIOR TO POURING NEW CONCRETE.
4. t = CONCRETE BASE DEPTH.
5. DOWEL BARS AND HOOK BOLT DOWELS SHALL NOT BE INSTALLED IN CONCRETE LESS THAN 200 mm THICK.

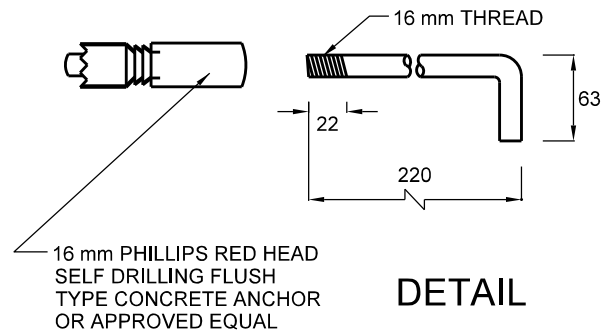

DETAIL

All dimensions are in millimetres unless otherwise shown.



ENGINEERING & CONSTRUCTION SERVICES STANDARD DRAWING

ANCHORED HOOK BOLT DOWEL AND CONCRETE REPAIR DETAIL

REV 2

SEP 2018

T-508.010-1

NTS

SHEET 1