

SECTION A-A

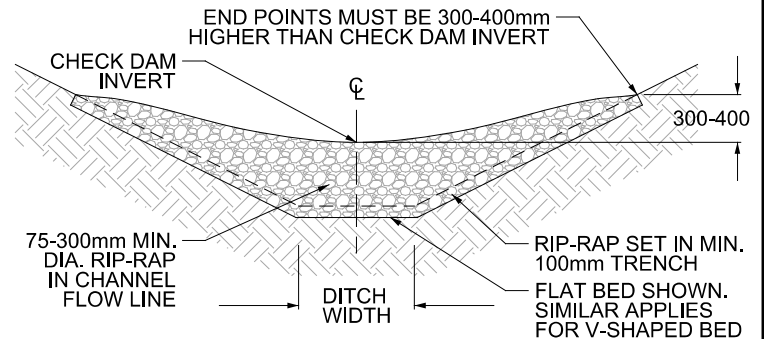

SECTION B-B

NOTES:

1. RIP-RAP TO BE AS PER OPSD STANDARDS.
2. CHECK DAM PLACEMENT TO BE SUCH THAT THE TOP OF THE DOWNSTREAM CHECK DAM ALIGNS WITH THE GROUND-DAM INTERFACE OF THE UPSTREAM CHECK DAM, OR AT A MAXIMUM SPACING OF 15m.
3. TOP OF CHECK DAM ELEVATION TO BE THE LOWER OF: 25mm BELOW THE ELEVATION OF THE UPSTREAM INLET ELEVATION, 50mm BELOW THE ELEVATION OF THE SIDEWALK ADJACENT TO THE CHECK DAM, OR 50mm BELOW THE ELEVATION OF THE TOP OF CURB ADJACENT TO THE CHECK DAM.
4. ENSURE THAT CHECK DAM ELEVATIONS DO NOT CAUSE STORMWATER TO OVERFLOW TO SIDEWALK.

All dimensions are in millimetres unless otherwise shown.



ENGINEERING & CONSTRUCTION SERVICES STANDARD DRAWING

CHECK DAM IN SOFTSCAPE - RIP-RAP

LAYOUT AND SECTIONS

REV 0

SEP 2021

T-850.033

NTS

SHEET 3