

PLAN

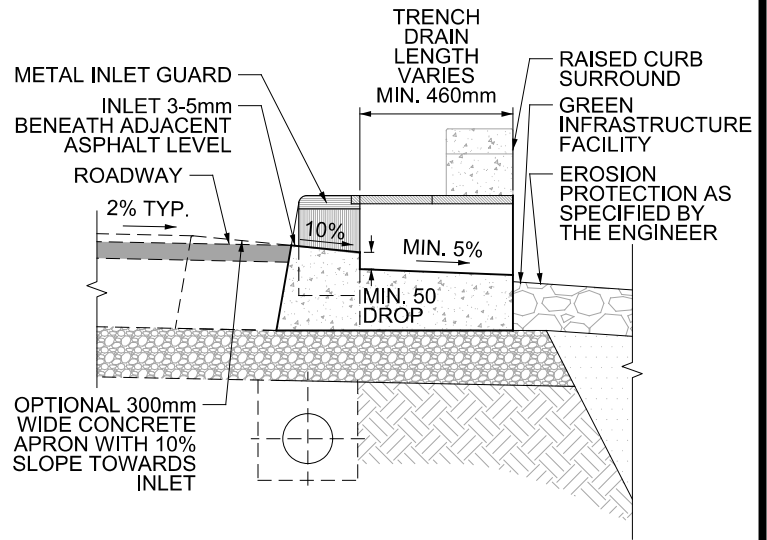

SECTION A-A

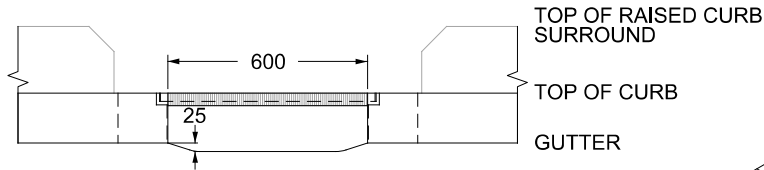

ELEVATION B-B

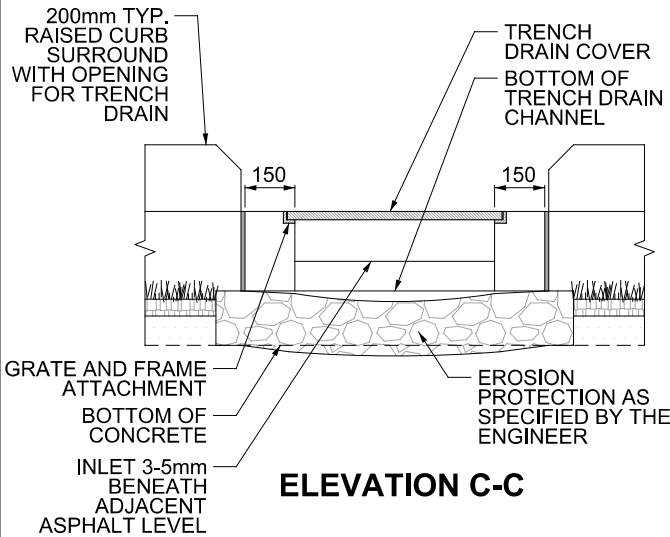

ELEVATION C-C

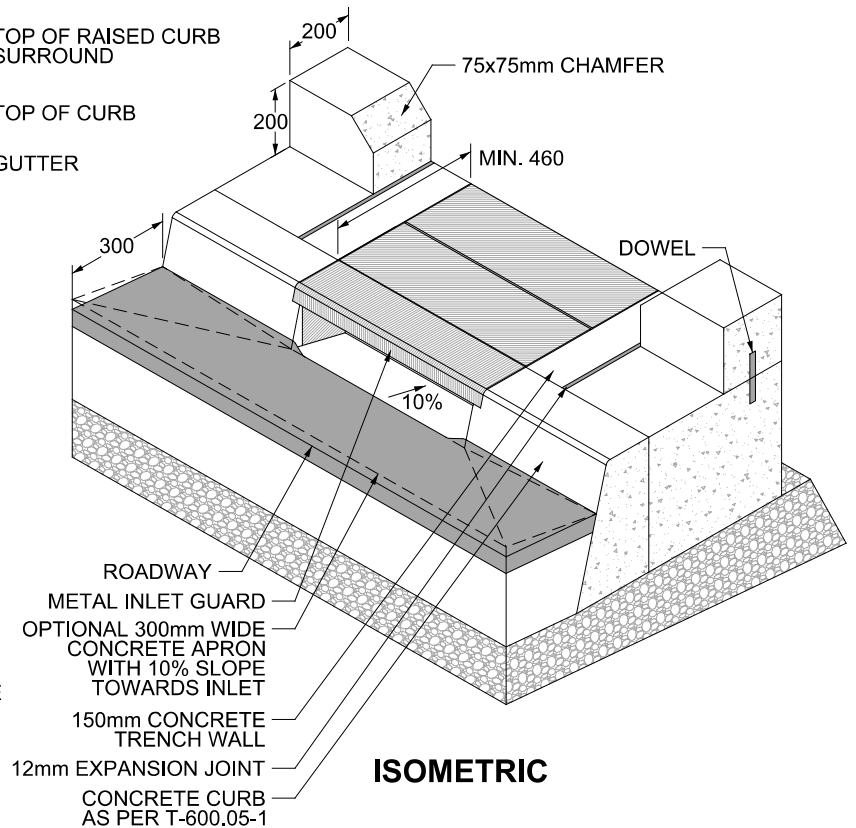

ISOMETRIC

- NOTES:
1. TRENCH DRAIN CHANNEL SLOPE TO BE 5% MIN. SLOPES MAY VARY WHERE APPROPRIATE. STEEPER SLOPES ARE RECOMMENDED FOR KEEPING INLET FREE OF DEBRIS.

All dimensions are in millimetres unless otherwise shown.



ENGINEERING & CONSTRUCTION SERVICES STANDARD DRAWING

SIDE INLET WITH TRENCH DRAIN - TYPE 2

TYPICAL DETAILS

REV 0 SEP 2021

T-850.106

NTS SHEET 6