

PLAN

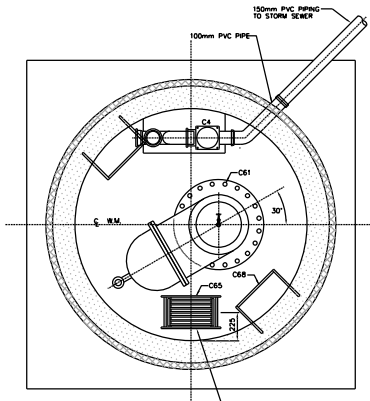

SECTION D

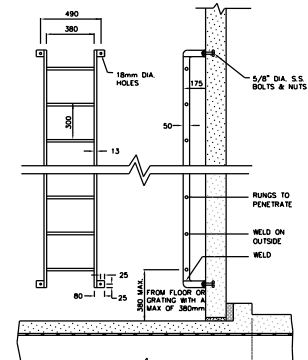

REMOVABLE ALUMINUM LADDER
NOT TO SCALE



SECTION THROUGH LADDER RUNG
FULL SIZE

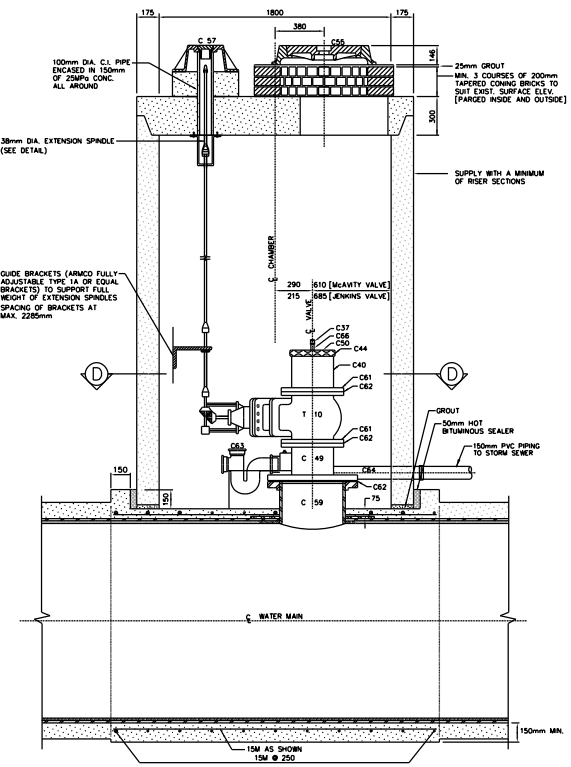

SECTION A

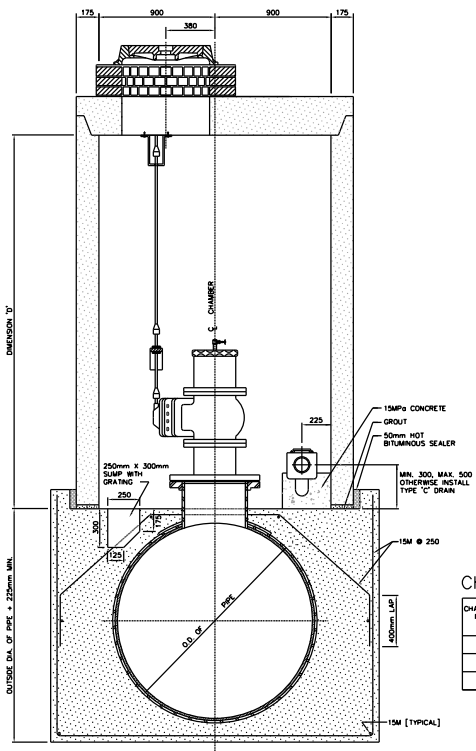

SECTION B

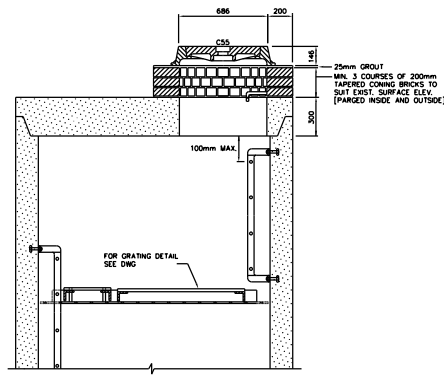

SECTION C

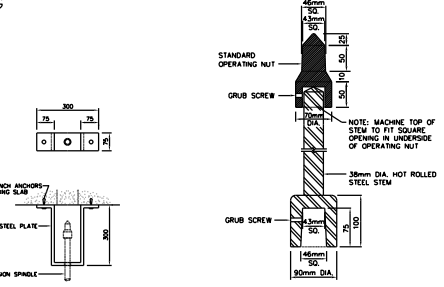

DETAIL OF EXTENSION SPINDLE
NOT TO SCALE

SPINDLE GUIDE BRACKET
NOT TO SCALE

MATERIAL LIST/PER CHAMBER

MARK No.	SUPPLIED BY CONTRACTOR	MARK No.	SUPPLIED BY CONTRACTOR
C49	1-FABRICATED S.S. 300mm NOZZLE	C4	1-100mm BACKWATER CHECK VALVE
C59	1-FABRICATED S.S. MAINTENANCE HOLE FRAME	C40	1-300mm FABRICATED S.S. FL. TO WCT.
C61	20-M30 x 125mm S.S. BOLTS & NUTS	C44	1-300mm WCT. COUPLING [STYLE 44 SHOULDER]
C61	12-M24 x 95mm S.S. BOLTS & NUTS	C50	1-300mm S.S. WCT. BLIND FLANGE WITH 20mm SCREENED BRASS PLUG
C61	CINCH ANCHORS WITH M16 DIA. S.S. BOLT & NUT	C57	1-SMALL ROUND TOP
C62	1-MAINTENANCE HOLE GASKET [FULL FACE, ONE PIECE]		
C62	1-300mm GASKET [FULL FACE, ONE PIECE]		
C63	1-100mm TRAP WITH CLEANOUT & COVER		
C64	1-100mm PVC PIPING AND 1-150mm TO 100mm REDUCER		
C65	1-SUMP FRAME & GRATING [ALUMINUM]		
C68	STANDARD ALUMINUM STEPS OR LADDERS AND GRATINGS		
C66	1-20mm x 100mm I.C. HEAVY DUTY BRASS NIPPLE, THREADED, TAPERED ENDS		
C80	38mm STEEL EXTENSION STEM & BRACKET		
C37	1-20mm BRONZE GATE VALVE, SOLID WEDGE, NON-RISING SPINDLE, CLASS 150, THREADED ENDS, LEAVING FIG. 1310 OR EQUIVALENT		
C55	1-CAST IRON SQUARE FRAME WITH CIRCULAR COVER AND PLUG FOR VALVE CHAMBERS AS PER QP60-402-D10		

● SUPPLY ONLY IF REQUIRED FOR DETAILS OF C49 AND C59 SEE DWG.

CHAMBERS

CHAMBER No.	CHAMBER	SURFACE ELEV.	WATERMAIN & ELEV. IN METRES	DIFFERENCE IN ELEV.	'D' DIM.	DRAIN TYPE (OUTLET DIR.)	COVER LOCATION	FOR LOCATION REFER TO PLAN No.



Toronto Engineering & Construction Services

GENERAL MANAGER, TORONTO WATER
DIRECTOR, Design and Construction Linear Underground Infrastructure
EXECUTIVE DIRECTOR, Engineering & Construction Services
MANAGER, Design and Construction Linear Underground Infrastructure

Title
Subfile1
Subfile2
PRECAST 300 mm DRAIN VALVE AND M.H. CHAMBER
DESIGN Design DRAWN Drawn CHECKED Checked CONTRACT No.,X-X
SCALE SCALE DRAWING NUMBER T-1110.07-6 SHEET X OF X
DATE DATE

No.	DATE	REVISIONS	INITIAL	SIGNED