

ELEVATION

NOTES:

1. CONTRACTION JOINTS TO BE SAWCUT AND PLACED AT A MAXIMUM OF 6m SPACING AND/OR COINCIDE WITH EXISTING JOINTS IN CONCRETE ROAD BASE.
2. EXPANSION JOINTS TO BE CONSTRUCTED USING 12mm WIDE BITUMINOUS FIBER TO THE FULL THICKNESS OF THE CURBS.
3. 600mm DRAINAGE GROOVES TO BE INSTALLED AT ROAD LOW POINT AND CATCH BASIN LOCATIONS, AND ALSO TO BE INSTALLED REQUIRED LENGTH AT DRIVEWAYS, LAY-BY AND ENTRANCES.
4. ALL CONCRETE EXPOSED SURFACES FINISH, ACCORDING TO SPECIFICATION TS 3.50 (LIGHT BRUSH TEXTURE).
5. DEPTH OF CONCRETE TO MATCH THE DEPTH OF ASPHALT PAVEMENT PER PLAN.
6. HORIZONTAL 15M REINFORCING BARS FOR ROAD SECTIONS THAT CURVE.
7. WHEN THERE IS CONCRETE BASE COURSE, INSTALL REBAR WITH EPOXY ADHESIVE INTO CONCRETE.

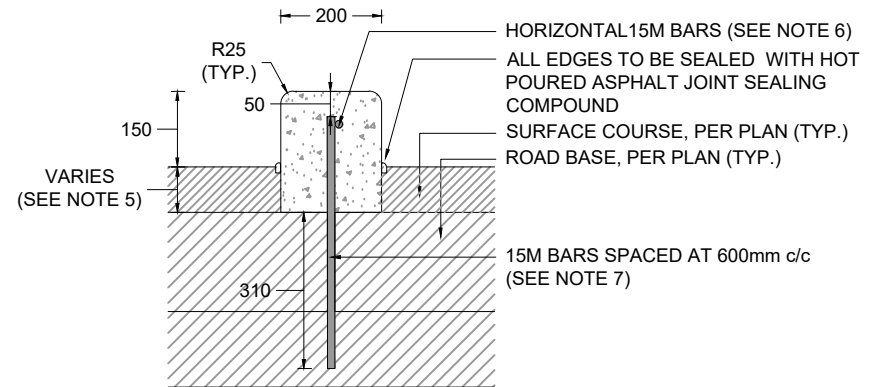

SECTION A - A

All dimensions are in millimetres unless otherwise shown.

ENGINEERING & CONSTRUCTION SERVICES STANDARD DRAWING

REV 0 SEP 2022

POURED IN PLACE CONCRETE CURB - TYPE A

T-603.043

NTS SHEET 1

