

**PANEL ELEVATION**

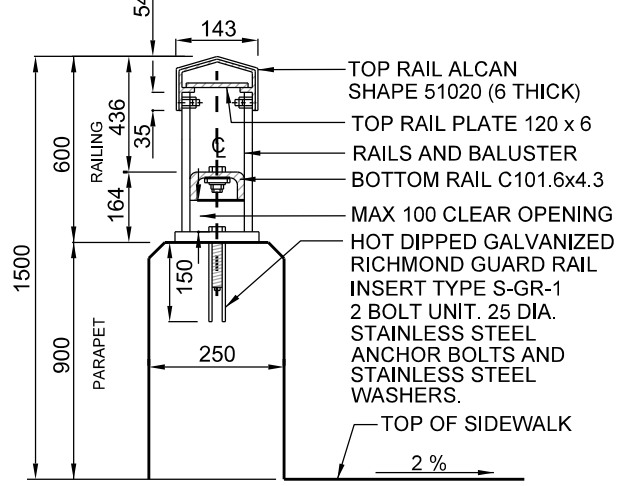

**SECTION A - A**

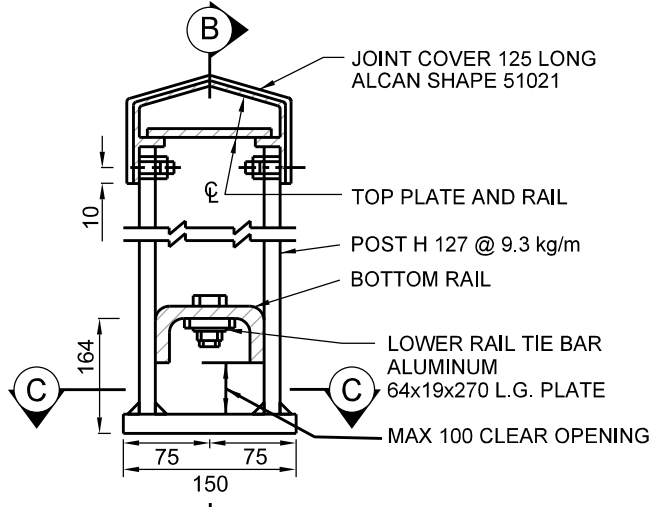

**POST DETAIL**

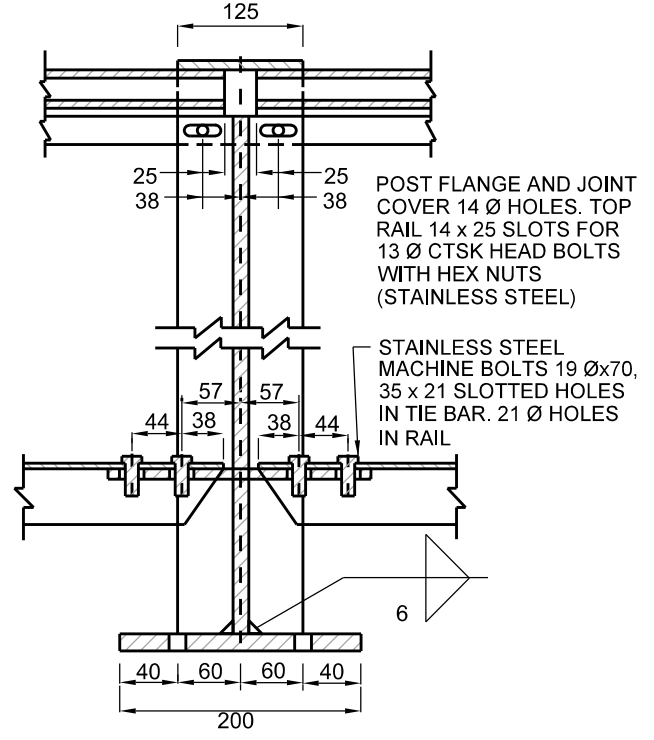

**SECTION B - B**

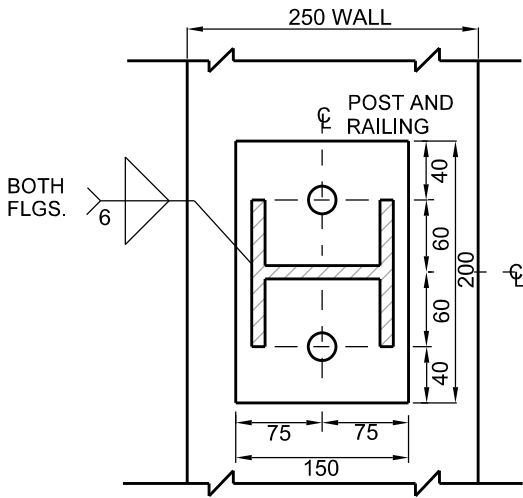

**SECTION C - C**

**NOTES:**

1. PAINT BOTTOM OF BASE PLATE WITH ASPHALTIC MASTIC.
2. POST AND BALUSTERS TO BE VERTICAL. TOP AND BOTTOM RAILS TO BE PARALLEL TO TOP OF CONCRETE.
3. GUARD (WALL) TO BE NON CLIMBABLE BETWEEN 140 AND 900 FROM PROTECTED SURFACE

MATERIAL	USE	SPECIFICATION
ALUMINUM - EXTRUDED SHAPES	POST AND RAILS	6351-T6 OR 6061-T6
ALUMINUM - TUBING	BALUSTERS	6351-T6 OR 6061-T6
ALUMINUM - SHEET AND PLATE	TOP BASE AND TIE PLATES	6351-T6 OR 6061-T6
STAINLESS STEEL TYPE 304	BOLTS	ASTM F593
	NUTS AND WASHERS	ASTM F594

All dimensions are in millimetres unless otherwise shown.



ENGINEERING & CONSTRUCTION SERVICES STANDARD DRAWING

**STANDARD ALUMINUM RAILING FOR  
SIDEWALKS AND WALLS WITH CONCRETE PARAPETS**

REV 3 SEP 2022

**T-900.01-2**

NTS SHEET 1