

ELEVATION

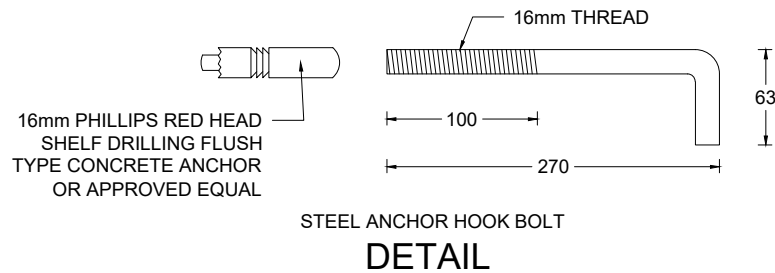

DETAIL

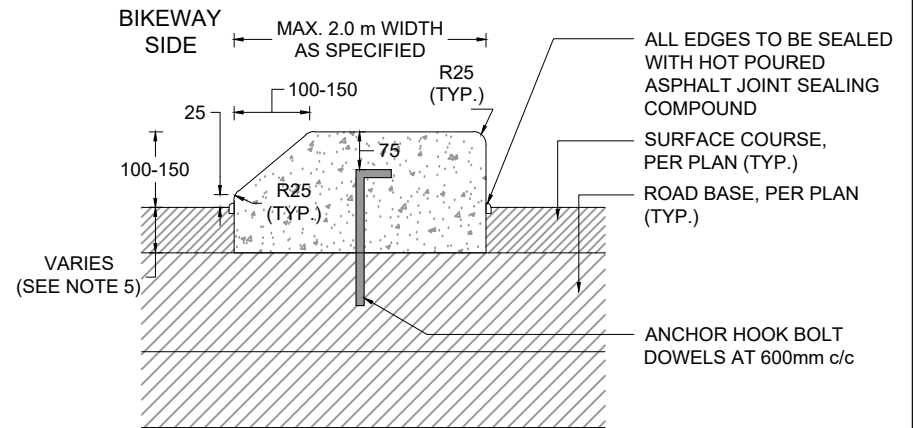

SECTION A - A

NOTES:

1. CONTRACTION JOINTS TO BE SAWCUT AND PLACED AT A MAXIMUM OF 6m SPACING AND/OR COINCIDE WITH EXISTING JOINTS IN CONCRETE ROAD BASE.
2. EXPANSION JOINTS TO BE CONSTRUCTED USING 12mm WIDE BITUMINOUS FIBER TO THE FULL THICKNESS OF THE CURBS.
3. 600mm DRAINAGE GROOVES TO BE INSTALLED AT ROAD LOW POINT AND CATCH BASIN LOCATIONS, AND ALSO TO BE INSTALLED REQUIRED LENGTH AT DRIVEWAYS, LAY-BY AND ENTRANCES.
4. ALL CONCRETE EXPOSED SURFACES FINISH, ACCORDING TO SPECIFICATION TS 3.50 (LIGHT BRUSH TEXTURE).
5. DEPTH OF CONCRETE TO MATCH THE DEPTH OF ASPHALT PAVEMENT PER PLAN.

All dimensions are in millimetres unless otherwise shown.

ENGINEERING & CONSTRUCTION SERVICES STANDARD DRAWING

REV 0 SEP 2022



BEVELED CONCRETE CURB

T-603.040

NTS SHEET 1