

NON-INTRUSIVE DETECTOR
PLACEMENT DETAIL

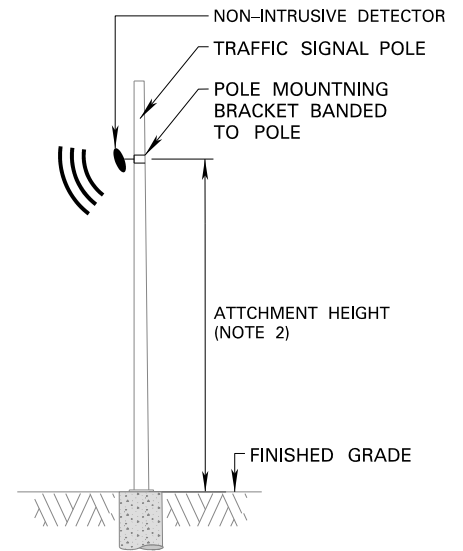

NON-INTRUSIVE DETECTOR
MOUNTING DETAIL

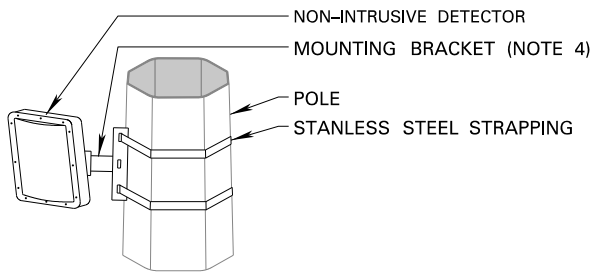

POLE MOUNT
BRACKET DETAIL

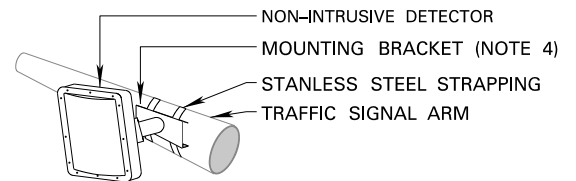

TRAFFIC ARM MOUNT
BRACKET DETAIL

NOTES

1. REFER TO CONTRACT DRAWINGS FOR NON-INTRUSIVE DETECTOR LOCATIONS.
2. NON-INTRUSIVE DETECTORS SHALL BE MOUNTED 4.5m TO 10.5m ABOVE FINISHED GRADE.
3. NON-INTRUSIVE DETECTORS SHALL BE INSTALLED NO LESS THAN 2.0m FROM THE DESIRED DETECTION ZONE(S) WITH A RANGE UP TO 42m.
4. STANDARD 152mm MOUNTING BRACKET FOR NON-INTRUSIVE DETECTOR.
5. WHERE POSSIBLE RADAR DETECTORS SHALL BE POSITIONED TO DETECT THE DETECTION ZONE INTENDED TO BE CAPTURED AS WELL AS CAPTURING ADDITIONAL APPROACHES WITHIN ITS DETECTION FIELD TO OPTIMIZE SCATS SYSTEM ZONE COVERAGE.